

# Driver Transistors

MMBTA0xLT1

## FEATURES

- We declare that the material of product compliance with RoHS requirements.  
**Pb-Free package is available**  
 RoHS product for packing code suffix "G"  
 Halogen free product for packing code suffix "H"



SOT-23

## MAXIMUM RATINGS

Rating	Symbol	Value		Unit
		MMBTA05	MMBTA06	
Collector–Emitter Voltage	$V_{CE0}$	60	80	Vdc
Collector–Base Voltage	$V_{CBO}$	60	80	Vdc
Emitter–Base Voltage	$V_{EBO}$	4.0		Vdc
Collector Current — Continuous	$I_C$	500		mAdc

## THERMAL CHARACTERISTICS

Characteristic	Symbol	Max	Unit
Total Device Dissipation FR–5 Board, (1) $T_A = 25^\circ\text{C}$	$P_D$	225	mW
Derate above $25^\circ\text{C}$		1.8	mW/ $^\circ\text{C}$
Thermal Resistance, Junction to Ambient	$R_{\theta JA}$	556	$^\circ\text{C}/\text{W}$
Total Device Dissipation Alumina Substrate, (2) $T_A = 25^\circ\text{C}$	$P_D$	300	mW
Derate above $25^\circ\text{C}$		2.4	mW/ $^\circ\text{C}$
Thermal Resistance, Junction to Ambient	$R_{\theta JA}$	417	$^\circ\text{C}/\text{W}$
Junction and Storage Temperature	$T_J, T_{stg}$	-55 to +150	$^\circ\text{C}$

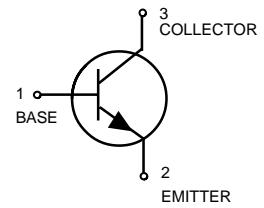

## DEVICE MARKING

MMBTA05LT1 = 1H, MMBTA06LT1 = 1GM

## ELECTRICAL CHARACTERISTICS ( $T_A = 25^\circ\text{C}$ unless otherwise noted.)

Characteristic	Symbol	Min	Max	Unit
----------------	--------	-----	-----	------

## OFF CHARACTERISTICS

Collector–Emitter Breakdown Voltage(3) ( $I_C = 1.0 \text{ mAdc}, I_B = 0$ )	$V_{(BR)CEO}$			Vdc
MMBTA05		60	—	
MMBTA06		80	—	
Emitter–Base Breakdown Voltage ( $I_E = 100 \mu\text{Adc}, I_C = 0$ )	$V_{(BR)EBO}$	4.0	—	Vdc
Collector Cutoff Current ( $V_{CE} = 60\text{Vdc}, I_B = 0$ )	$I_{CES}$	—	0.1	$\mu\text{Adc}$
Emitter Cutoff Current ( $V_{CB} = 60\text{Vdc}, I_E = 0$ )	$I_{CBO}$	—	0.1	$\mu\text{Adc}$
( $V_{CB} = 80\text{Vdc}, I_E = 0$ )		—	0.1	

- FR–5 =  $1.0 \times 0.75 \times 0.062$  in.
- Alumina =  $0.4 \times 0.3 \times 0.024$  in. 99.5% alumina.
- Pulse Test: Pulse Width  $\leq 300 \mu\text{s}$ , Duty Cycle  $\leq 2.0\%$ .

**ELECTRICAL CHARACTERISTICS** ( $T_A = 25^\circ\text{C}$  unless otherwise noted) (Continued)

Characteristic	Symbol	Min	Max	Unit
----------------	--------	-----	-----	------

**ON CHARACTERISTICS**

DC Current Gain ( $I_C = 10\text{ mAdc}$ , $V_{CE} = 1.0\text{ Vdc}$ ) ( $I_C = 100\text{ mAdc}$ , $V_{CE} = 1.0\text{ Vdc}$ )	$h_{FE}$	100 100	— —	—
Collector–Emitter Saturation Voltage ( $I_C = 100\text{ mAdc}$ , $I_B = 10\text{ mAdc}$ )	$V_{CE(sat)}$	—	0.25	Vdc
Base–Emitter On Voltage ( $I_C = 100\text{ mAdc}$ , $V_{CE} = 1.0\text{ Vdc}$ )	$V_{BE(sat)}$	—	1.2	Vdc

**SMALL–SIGNAL CHARACTERISTICS**

Current –Gain – Bandwidth Product(4) ( $V_{CE} = 2.0\text{ V}$ , $I_C = 10\text{ mA}$ , $f = 100\text{ MHz}$ )	$f_T$	100	—	MHz
---	-------	-----	---	-----

4.  $f_T$  is defined as the frequency at which  $|h_{fe}|$  extrapolates to unity.

**ORDERING INFORMATION**

Device	Marking	Shipping
MMBTA05LT1	1H	3000/Tape & Reel
MMBTA06LT1	1GM	3000/Tape & Reel

**SOT-23**

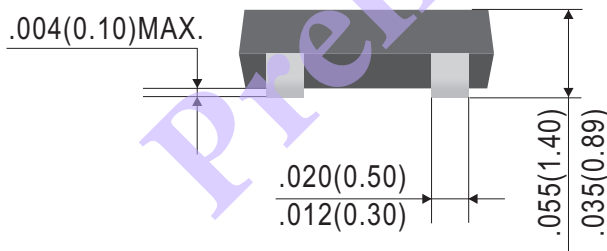
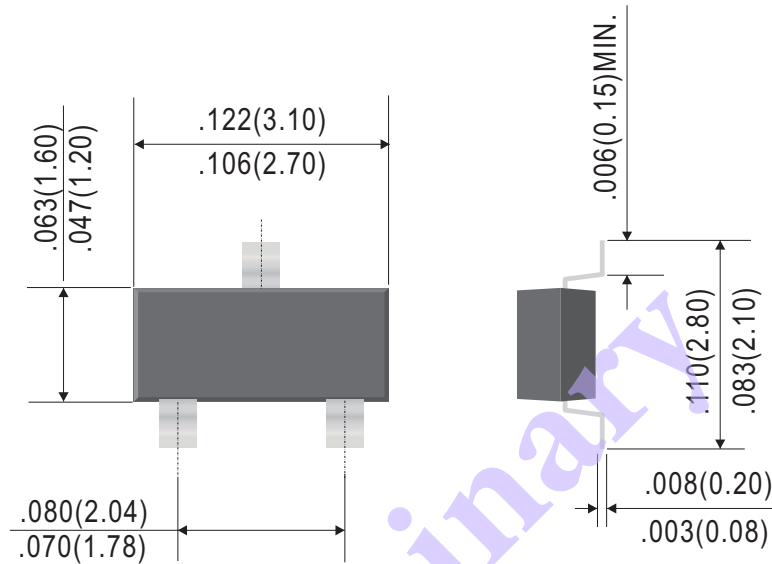

Dimensions in inches and (millimeters)

