

REPLACEMENT TYPE : 2SA1015

FEATURES

- High voltage And High Current
- Excellent h_{FE} Linearity
- Low noise
- Complementary to HAC1815

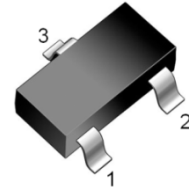

SOT-23 MARKING:BA

1: BASE 2:EMITTER 3: COLLECTOR

MAXIMUM RATINGS ($T_A = 25^\circ\text{C}$ unless otherwise noted)

Parameter	Symbol	Value	Unit
Collector-Base Voltage	V_{CBO}	-50	V
Collector-Emitter Voltage	V_{CEO}	-50	V
Emitter-Base Voltage	V_{EBO}	-5	V
Collector Current-Continuous	I_C	-150	mA
Collector Power Dissipation	P_C	400	mW
Thermal Resistance Junction to Ambient	$R_{\theta JA}$	312	$^\circ\text{C}/\text{W}$
Junction Temperature	T_J	150	$^\circ\text{C}$
Storage Temperature	T_{stg}	-55 to +150	$^\circ\text{C}$

ELECTRICAL CHARACTERISTICS ($T_A = 25^\circ\text{C}$ unless otherwise noted)

Parameter	Symbol	Test conditions	Min	Typ	Max	Unit
Collector-Base Breakdown Voltage	V_{CBO}	$I_C = -100\mu\text{A}, I_E = 0$	-50			V
Collector-Emitter Breakdown Voltage	V_{CEO}	$I_C = -0.1\text{mA}, I_B = 0$	-50			V
Emitter-Base Breakdown Voltage	V_{EBO}	$I_E = -100\mu\text{A}, I_C = 0$	-5			V
Collector Cut-off Current	I_{CBO}	$V_{CB} = -50\text{V}, I_E = 0$			-0.1	μA
Collector Cut-off Current	I_{CEO}	$V_{CB} = -50\text{V}, I_E = 0$			-0.1	μA
Emitter Cut-off Current	I_{EBO}	$V_{EB} = -5\text{V}, I_C = 0$			-0.1	μA
DC Current Gain	h_{FE}	$V_{CE} = -6\text{V}, I_C = -2\text{mA}$	130		400	
Collector-Emitter Saturation Voltage	$V_{CE(sat)}$	$I_C = -100\text{mA}, I_B = -10\text{mA}$			-0.3	V
Base-Emitter Saturation Voltage	$V_{BE(sat)}$	$I_C = -100\text{mA}, I_B = -10\text{mA}$			-1.1	V
Transition Frequency	f_T	$V_{CE} = -10\text{V}, I_C = -1\text{mA}, f = 30\text{MHz}$	80			MHz

CLASSIFICATION OF h_{FE}

Rank	L	H
Range	130-200	200-400

Typical Characteristics

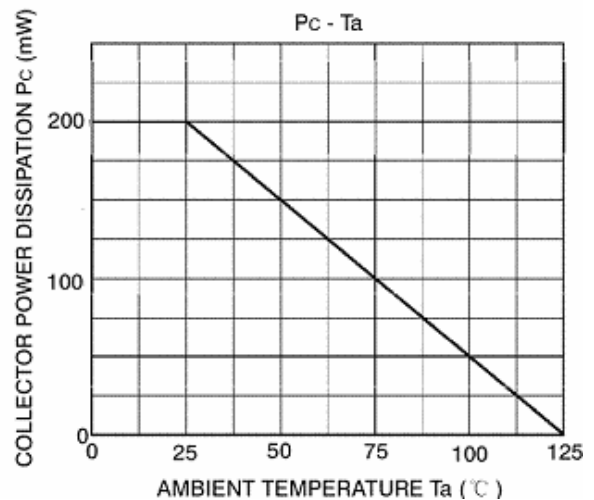
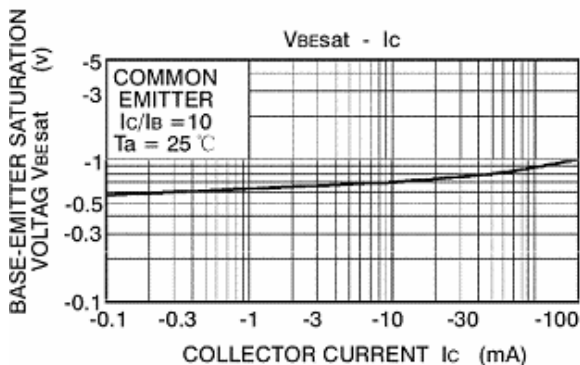
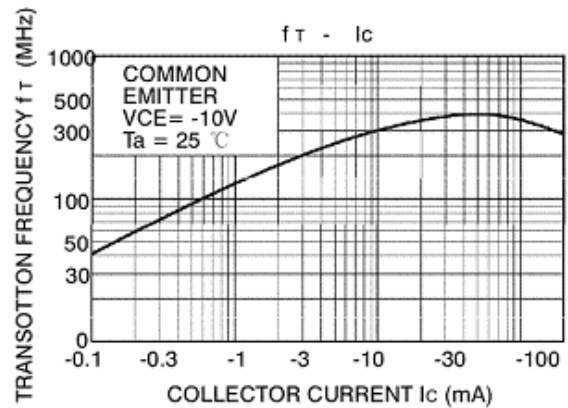
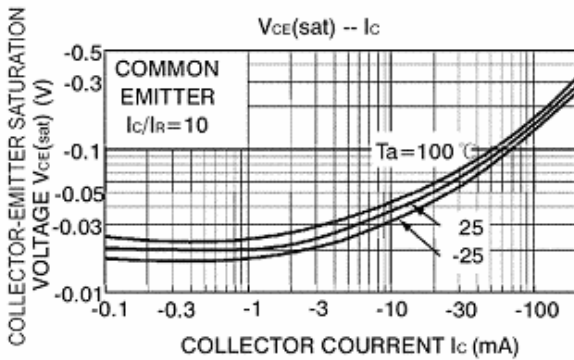
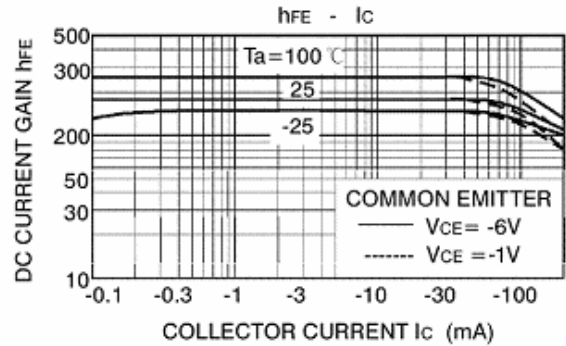
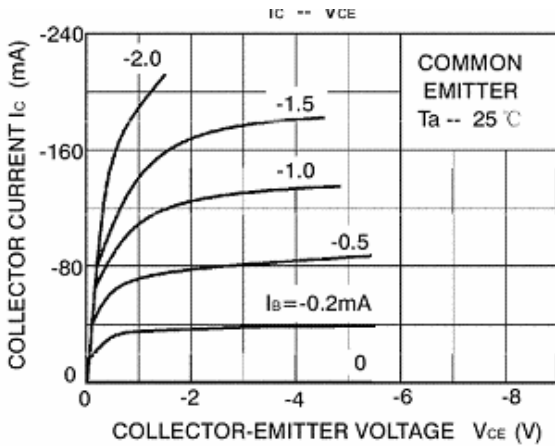

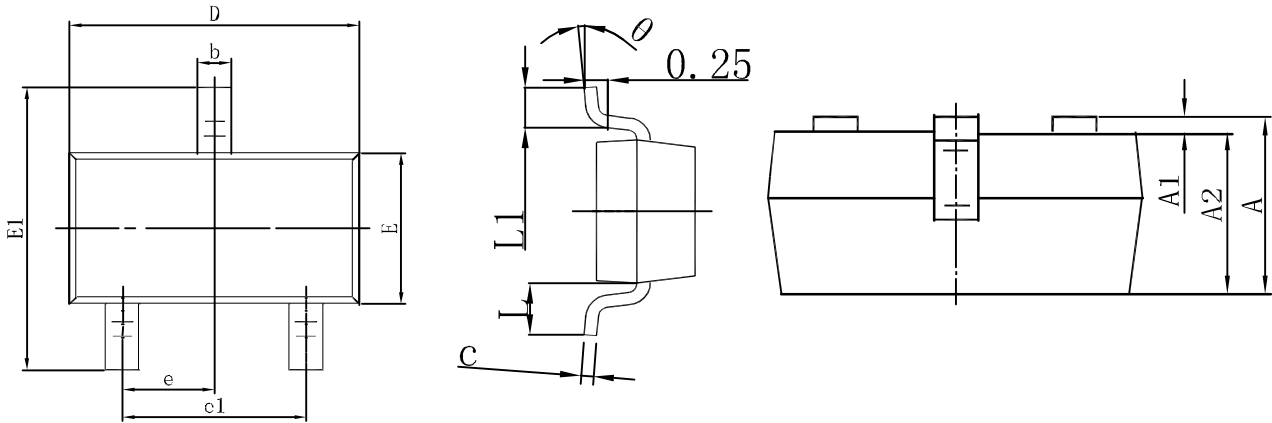
SOT-23 Package Outline Dimensions

Symbol	Dimensions In Millimeters		Dimensions In Inches	
	Min.	Max.	Min.	Max.
A	0.900	1.150	0.035	0.045
A1	0.000	0.100	0.000	0.004
A2	0.900	1.050	0.035	0.041
b	0.300	0.500	0.012	0.020
c	0.080	0.150	0.003	0.006
D	2.800	3.000	0.110	0.118
E	1.200	1.400	0.047	0.055
E1	2.250	2.550	0.089	0.100
e	0.950 TYP		0.037 TYP	
e1	1.800	2.000	0.071	0.079
L	0.550 REF		0.022 REF	
L1	0.300	0.500	0.012	0.020
θ	0°	8°	0°	8°

SOT-23 Embossed Carrier Tape

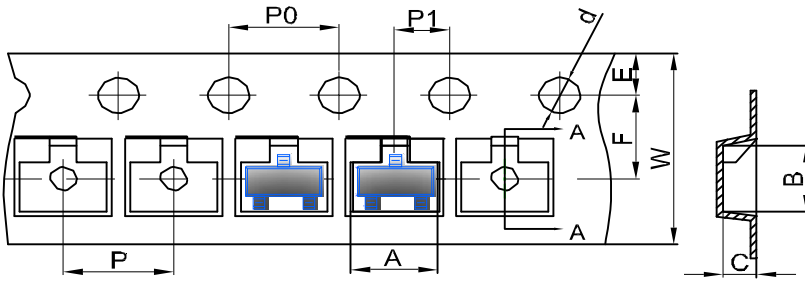

DIMENSIONS ARE IN MILLIMETER										
TYPE	A	B	C	d	E	F	P0	P	P1	W
SOT-23	3.15	2.77	1.22	φ1.50	1.75	3.50	4.00	4.00	2.00	8.00
TOLERANCE	±0.1	±0.1	±0.1	±0.1	±0.1	±0.1	±0.1	±0.1	±0.1	±0.1

SOT-23 Tape Leader and Traller

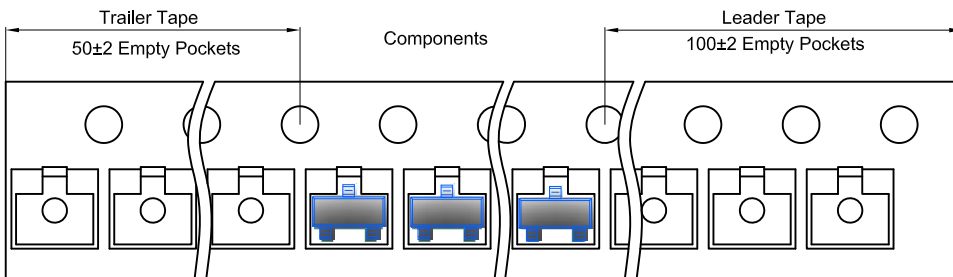

SOT-23 Reel

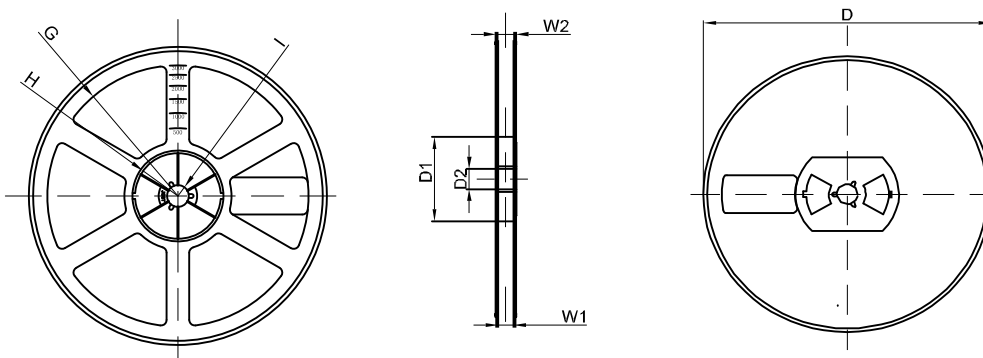

DIMENSIONS ARE IN MILLIMETER								
REEL OPTION	D	D1	D2	G	H	I	W1	W2
7" DIA	φ178	54.40	13.00	R78	R25.60	R6.50	9.50	12.30
TOLERANCE	±2	±1	±1	±1	±1	±1	±1	±1