

Customer Information Sheet

DRAWING No.: S25-XX2

IF IN DOUBT - ASK

©

NOT TO SCALE

THIRD ANGLE PROJECTION

ALL DIMENSIONS IN mm

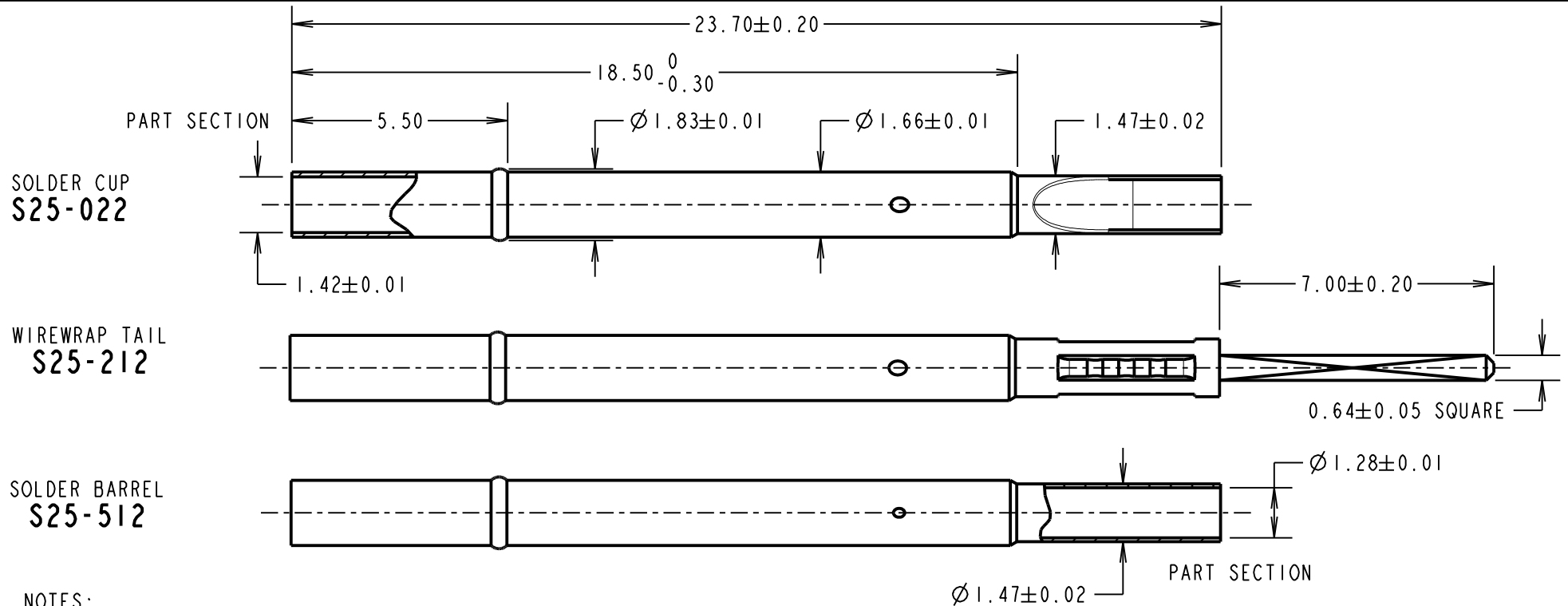

NOTES:

1. TO BE USED WITH PROBES P25-0822 AND P25-XX23.
2. SUITABLE FOR A MINIMUM DISTANCE BETWEEN CENTRES OF 2.54mm.
3. SPECIFICATIONS FOR PROBE PERFORMANCE ARE GIVEN ON THE PROBE DRAWING.
4. RECOMMENDED HOLE SIZES: $\varnothing 1.75\text{mm}$
5. S25-022 & S25-512 ARE SUITABLE FOR USE WITH 22, 24, 26, 28 & 30 AWG WIRE (SOLDER).
6. PLATING = 0.05 μ GOLD OVER 2.03-3.05 μ NICKEL.

MSP	4	28.01.16	13249
NAME	ISS.	DATE	C/NOTE
APPROVED: M.PERREN			
CHECKED: S.BENNETT			
DRAWN: M.PERREN			
CUSTOMER REF.:			
ASSEMBLY DRG:			

ORDER CODE:
S25-XX2
 SPRING PROBE
 SLEEVE (SEE ABOVE)

HARWIN

www.harwin.com
 technical@harwin.com

THIS DRAWING AND ANY INFORMATION OR DESCRIPTIVE MATTER SET OUT HEREON ARE CONFIDENTIAL AND COPYRIGHT PROPERTY OF THE HARWIN GROUP AND MUST NOT BE DISCLOSED, LOANED, COPIED OR USED FOR MANUFACTURING, TENDERING OR FOR ANY OTHER PURPOSE WITHOUT THEIR WRITTEN PERMISSION.

TOLERANCES
 X. = $\pm 1\text{mm}$
 X.X = $\pm 0.50\text{mm}$
 X.XX = $\pm 0.10\text{mm}$
 X.XXX = $\pm 0.01\text{mm}$
 ANGLES = $\pm 5^\circ$
 UNLESS STATED

MATERIAL:

BRASS

FINISH: SEE ABOVE

S/AREA:

mm²

TITLE:

2.54mm MIN. CENTRE TWO-PIECE
 SPRING PROBE SLEEVE

DRAWING NUMBER:

S25-XX2

SHT
 2
 OF
 2