

REV.	E.C.N. NUMBER AND REVISION COMMENTS	DATE
A	E.C.N. #10810. & REDRAWN IN 3D.	11.12.01

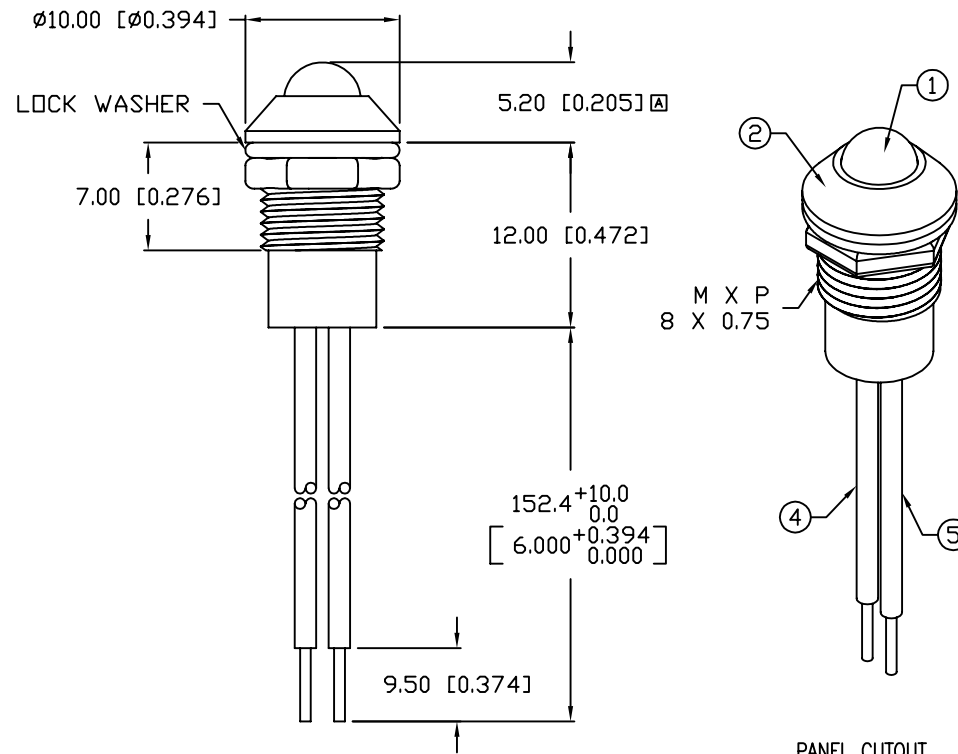

PANEL CUTOUT

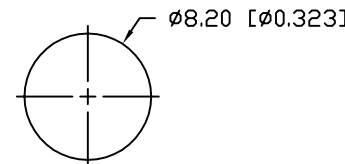

NOTES:

1. SSL-LX5093SOC, ORANGE LED. TRIM LEADS TO 4mm.
2. SSI-LXR3816-B, BLACK ANODIZED HOUSING.
3. SSH-LXH4815BSG, BUSHING (NOT SHOWN). INSERT AND CRIMP.
4. ANODE LEAD: LXP-WST24RDTOC, 24 AWG., TINNED OVERCOAT, RED INSULATION. CUT 160mm LONG, STRIP BOTH ENDS 3mm & 9.5mm.
5. CATHODE LEAD: LXP-WST24BLTOC, 24 AWG., TINNED OVERCOAT, BLACK INSULATION. CUT 160mm LONG, STRIP BOTH ENDS 3mm & 9.5mm.
6. CRIMP WIRES TO LED LEADS.

ELECTRO-OPTICAL CHARACTERISTICS $T_A=25^\circ\text{C}$ $I_f=20\text{mA}$

PARAMETER	MIN	TYP	MAX	UNITS	TEST COND
PEAK WAVELENGTH		610		nm	
FORWARD VOLTAGE		2.0	2.5	V_f	
REVERSE VOLTAGE	5.0			V_r	$I_r=100\mu\text{A}$
AXIAL INTENSITY	1500	2500		mcd	$I_f=20\text{mA}$
VIEWING ANGLE		25		2x theta	
EMITTED COLOR:	ORANGE				
EPOXY LENS FINISH:	WATER CLEAR				

LIMITS OF SAFE OPERATION AT 25°C

PARAMETER	MAX	UNITS
PEAK FORWARD CURRENT*	150	mA
STEADY CURRENT	50	mA
POWER DISSIPATION	125	mW
DERATE FROM 25°C	-2.0	mW/°C
OPERATING, STORAGE TEMP.	-40 TO +85	°C

* $t < 10\mu\text{s}$

*UNLESS OTHERWISE SPECIFIED TOLERANCES PER DECIMAL PRECISION ARE: X=±1 (±0.039), X.X=±0.5 (±0.020), X.XX=±0.25 (±0.010), X.XXX=±0.127 (±0.005). LEAD SIZE=±0.05 (±0.002), LEAD LENGTH=±0.75 (±0.030). MIN= $\begin{matrix} +\text{DECIMAL PRECISION} \\ -0.00 \end{matrix}$ MAX= $\begin{matrix} +0.00 \\ -\text{DECIMAL PRECISION} \end{matrix}$

REV.	PART NUMBER
A	SSI-LXR3816SOC-B15

CONFIDENTIAL INFORMATION
THE INFORMATION CONTAINED IN THIS DOCUMENT IS THE PROPERTY OF LUMEX INC. EXCEPT AS SPECIFICALLY AUTHORIZED IN WRITING BY LUMEX INC., THE HOLDER OF THIS DOCUMENT SHALL KEEP ALL INFORMATION CONTAINED HEREIN CONFIDENTIAL AND SHALL PROTECT SAME IN WHOLE OR IN PART FROM DISCLOSURE AND DISSEMINATION TO ALL THIRD PARTIES.



290 E. HELEN ROAD
PALATINE, IL 60067-6976
PHONE: +1.847.359.2790
US WEB: www.lumex.com
TW WEB: www.lumex.com.tw

T-5mm 610nm AlInGaP ORANGE LED PANEL INDICATOR,
WATER CLEAR LENS, 6.0" WIRE LEADS.

RELIABILITY NOTE
OUR MANY YEARS OF EXPERIENCE DATA ACCUMULATION INDICATE THAT SOLDER HEAT IS A MAJOR CAUSE OF EARLY AND FUTURE FAILURE. PLEASE PAY ATTENTION TO YOUR SOLDERING PROCESS.

DRAWN BY: BC	CHECKED BY:	APPROVED BY: JD	DATE: 8.8.00 PAGE: 1 OF 1 SCALE: N/A
-----------------	-------------	--------------------	--