

Digital Attenuator, 5-Bit, Single Control 31 dB, 0.05 - 4.0 GHz

Rev. V3

Features

- Integrated Logic
- Positive Single Control
- Insertion Loss: 1.5 dB @ 1.0 GHz
- IP3: >40 dBm typical @ 2.0 GHz
- Attenuation Accuracy: 0.3 dB + 1% @ 1.0 GHz
- 1-dB Attenuation Steps to 31 dB
- Low DC Power Consumption
- Lead-Free 3mm PQFN-16LD Plastic Package
- Halogen-Free "Green" Mold Compound
- RoHS* Compliant and 260°C Re-flow Compatible

Description

The MAADSS0016 is a 5-Bit, 1dB step GaAs MMIC digital attenuator in a lead-free 3mm 16 lead PQFN surface mount plastic package. This device is ideally suited for use where high accuracy, very low power consumption and low intermodulation products are required.

Typical applications include radio, cellular, wireless LANs, GPS equipment and other gain / level control circuits.

The MAADSS0016 is part of a digital attenuator family. This family includes 4, 5, and 6 bit attenuators with 0.5, 1, or 2 dB steps and up to 31.5 range.

Ordering Information ^{1,2}

Part Number	Package
MAADSS0016TR-1000	1000 piece reel
MAADSS0016TR-3000	3000 piece reel
MAADSS0016SMB	Sample Board

1. Reference Application Note M513 for reel size information.
2. All sample boards include 5 loose parts.

Functional Schematic ^{3,4}

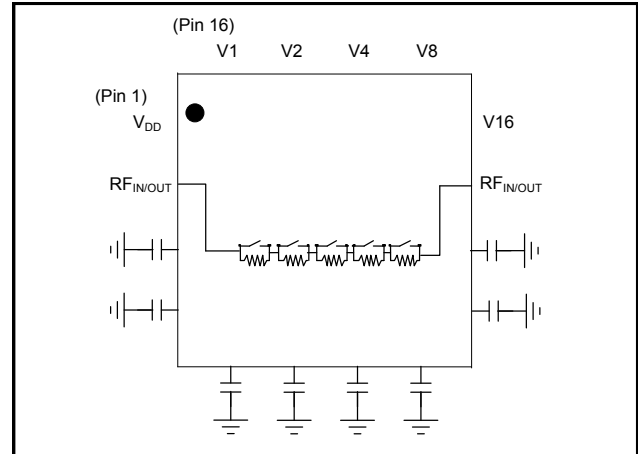

3. Blocking capacitors are required on all RF ports.
4. RF Port and Ground pin capacitors are 1000 pF.

Pin Configuration ⁵

Pin No.	Function	Pin No.	Function
1	V _{DD}	9	Ext. C to GND
2	RF _{IN/OUT}	10	Ext. C to GND
3	Ext. C to GND	11	RF _{IN/OUT}
4	Ext. C to GND	12	V16 (16 dB Bit)
5	Ext. C to GND	13	V8 (8 dB Bit)
6	Ext. C to GND	14	V4 (4 dB Bit)
7	Ext. C to GND	15	V2 (2 dB Bit)
8	Ext. C to GND	16	V1 (1 dB Bit)

5. The exposed pad centered on the package bottom should be grounded.

Absolute Maximum Ratings ^{6,7}

Parameter	Absolute Maximum
Input Power 500 - 4000 MHz	+33 dBm
Control Voltage	-0.5 V ≤ V _C ≤ 5.5 V
Operating Temperature	-40°C to +85°C
Storage Temperature	-65°C to +150°C

6. Exceeding any one or combination of these limits may cause permanent damage to this device.
7. M/A-COM Technology Solutions does not recommend sustained operation near these survivability limits.

* Restrictions on Hazardous Substances, European Union Directive 2002/95/EC.

Digital Attenuator, 5-Bit, Single Control 31 dB, 0.05 - 4.0 GHz

Rev. V3

Electrical Specifications^{8,9}: $T_A = 25^\circ\text{C}$, $Z_0 = 50\ \Omega$, $V_{DD} = 2.8$ to 5V , $V_C = 2.5\ \text{V}$

Parameter	Test Conditions	Units	Min.	Typ.	Max.
Reference Insertion Loss	1.0 GHz	dB	—	1.5	3.0
Attenuation Accuracy	1.0 GHz All bits except 31 dB	$\pm (0.3\ \text{dB} + 1\% \text{ of attenuation setting in dB})\ \text{dB}$			
Attenuation Accuracy	1.0 GHz, 31 dB	dB	30	—	32
VSWR	0.05 - 4.0 GHz	Ratio	—	1.5:1	—
T_{RISE} , T_{FALL}	10% to 90% RF, 90% to 10% RF	ns	—	40	—
Ton, Toff	50% Control to 90% RF, 50% Control to 10% RF	ns	—	65	—
Transients	In Band	mV	—	75	—
Input P1dB	2.0 GHz	dBm	—	30	—
Input IP ₂	2-Tone, +5 dBm/tone, 1 MHz Spacing 0.5 GHz 2.0 GHz	dBm	—	75 80	—
Input IP ₃	2-Tone, +5 dBm/tone, 1 MHz Spacing 0.5, 2.0 GHz	dBm	—	42	—
I_C	$V_C = 2.5\ \text{V}$	μA	—	20	25
I_{DD}	$V_{DD} = 5\ \text{V}$	μA	—	200	300

8. External DC blocking capacitors are required on all RF ports.

9. Low frequency is determined by DC block and GND capacitor value.

Truth Table¹⁰

VC1	VC2	VC4	VC8	VC16	Attenuation (dB)
0	0	0	0	0	Reference IL
1	0	0	0	0	1
0	1	0	0	0	2
0	0	1	0	0	4
0	0	0	1	0	8
0	0	0	0	1	16
1	1	1	1	1	31

10. 0 = 0V, 1 = +2.5 to 5V.

Handling Procedures

Please observe the following precautions to avoid damage:

Static Sensitivity

Gallium Arsenide Integrated Circuits are sensitive to electrostatic discharge (ESD) and can be damaged by static electricity. Proper ESD control techniques should be used when handling these devices.

Recommended PCB

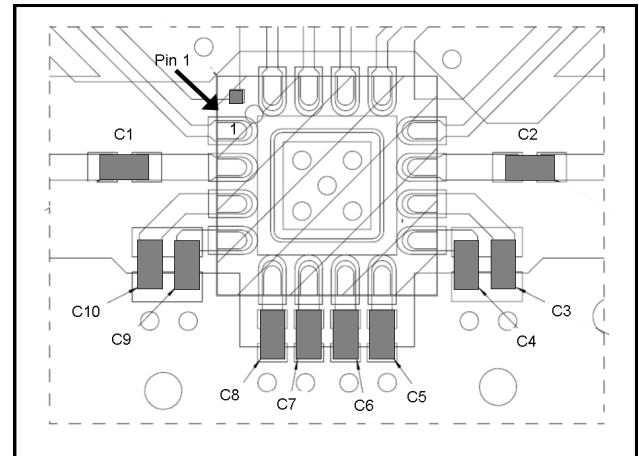

Off-Chip Component Values

Component	Value	Package
C1 - C10	1000 Pf	0201

Typical Performance Curves

Insertion Loss

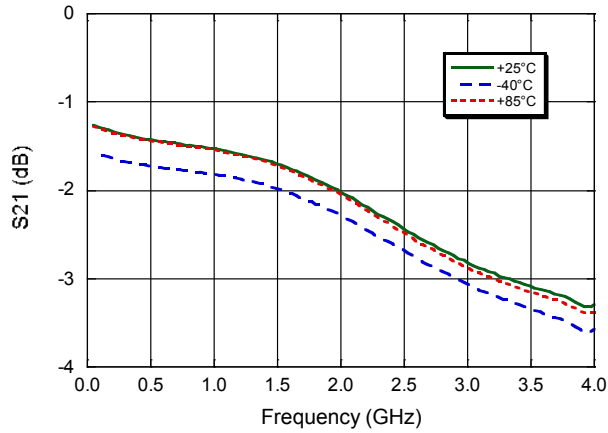

Relative Attenuation across all states

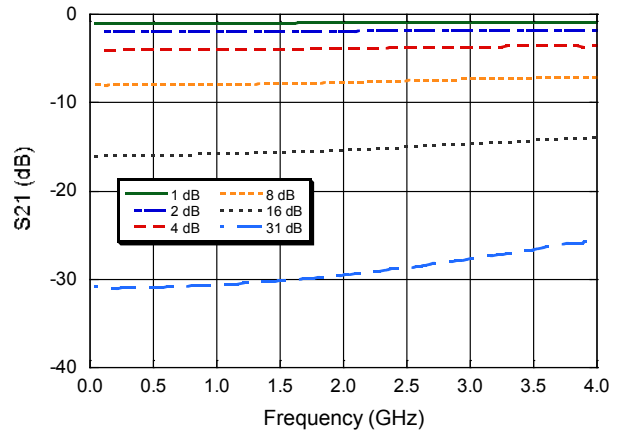

Input Return Loss, Insertion Loss State

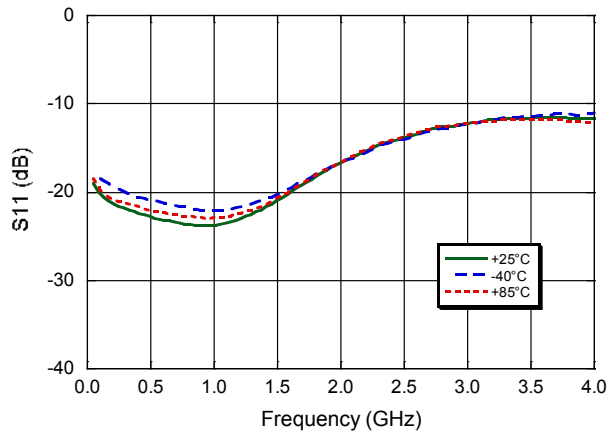

Input Return Loss, across all attenuation states

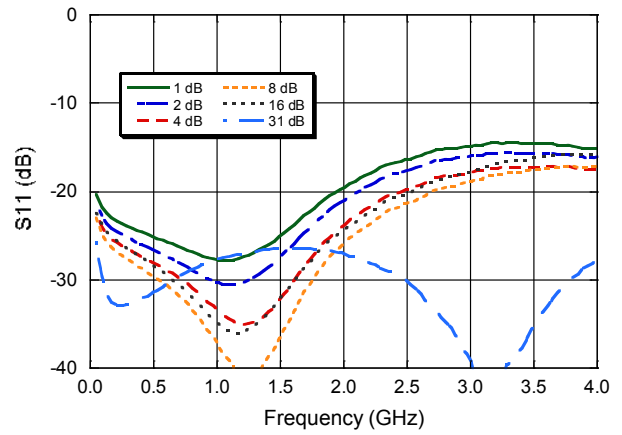

Output Return Loss, Insertion Loss State

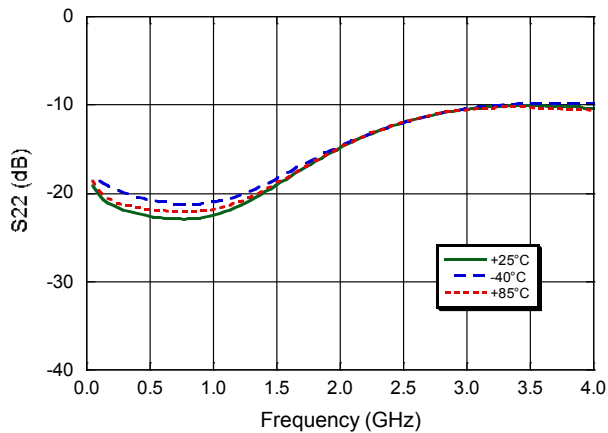

Output Return Loss, across all attenuation states

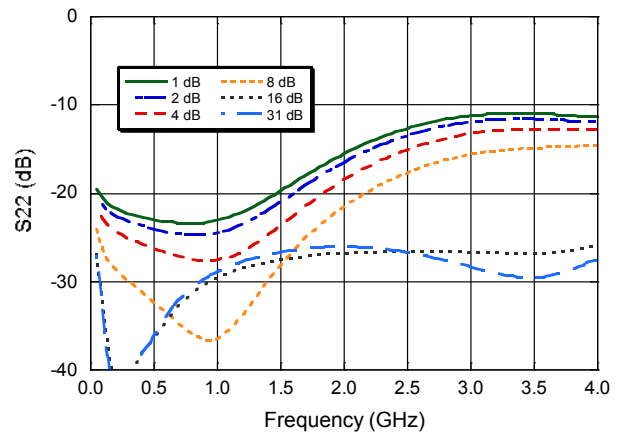

Digital Attenuator, 5-Bit, Single Control 31 dB, 0.05 - 4.0 GHz

Rev. V3

Typical Performance Curves

Input IP3 @ 0.5 GHz

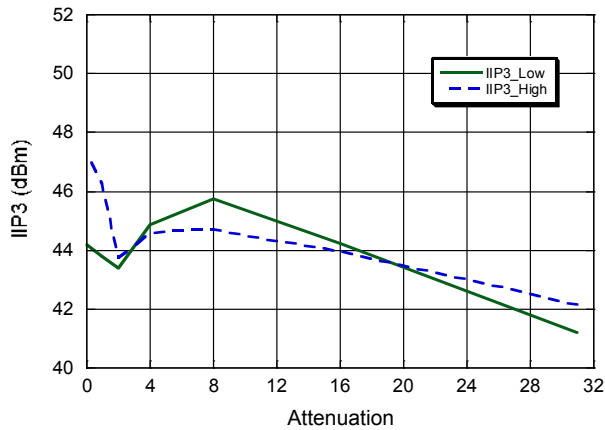

Input IP3 @ 2 GHz

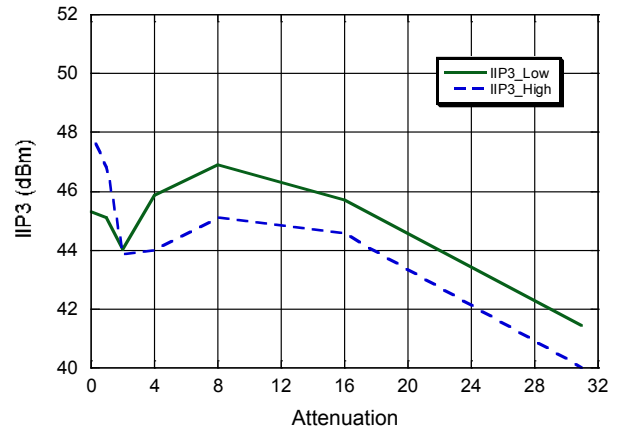

Lead Free 3 mm 16-Lead PQFN †

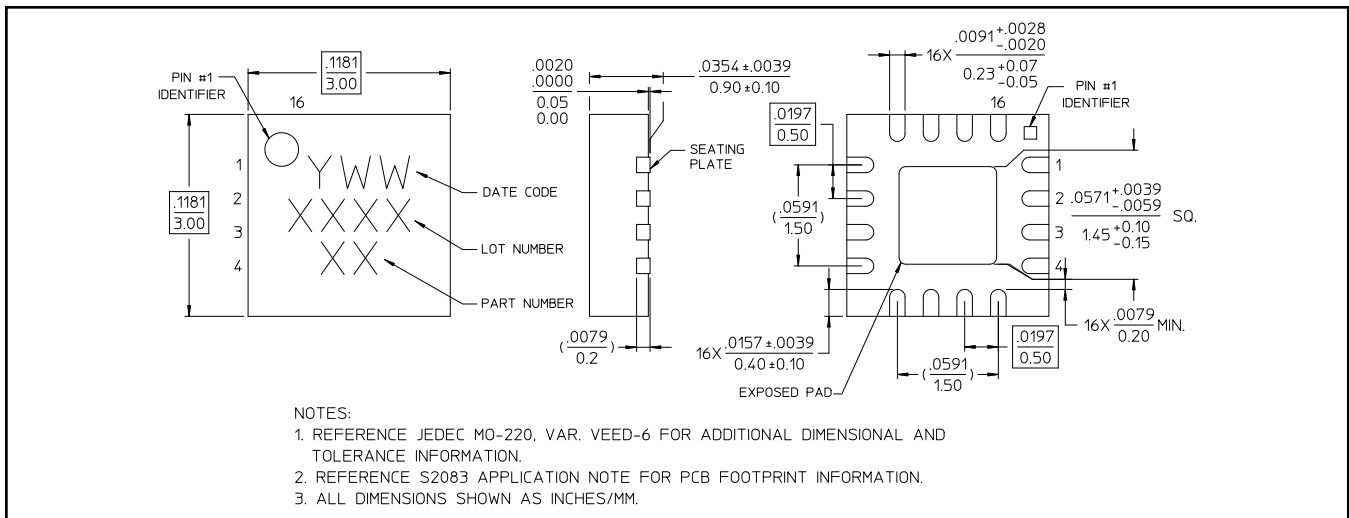

† Reference Application Note S2083 for lead-free solder reflow recommendations.
 Meets JEDEC moisture sensitivity level 1 requirements.

M/A-COM Technology Solutions Inc. All rights reserved.

Information in this document is provided in connection with M/A-COM Technology Solutions Inc ("MACOM") products. These materials are provided by MACOM as a service to its customers and may be used for informational purposes only. Except as provided in MACOM's Terms and Conditions of Sale for such products or in any separate agreement related to this document, MACOM assumes no liability whatsoever. MACOM assumes no responsibility for errors or omissions in these materials. MACOM may make changes to specifications and product descriptions at any time, without notice. MACOM makes no commitment to update the information and shall have no responsibility whatsoever for conflicts or incompatibilities arising from future changes to its specifications and product descriptions. No license, express or implied, by estoppel or otherwise, to any intellectual property rights is granted by this document.

THESE MATERIALS ARE PROVIDED "AS IS" WITHOUT WARRANTY OF ANY KIND, EITHER EXPRESS OR IMPLIED, RELATING TO SALE AND/OR USE OF MACOM PRODUCTS INCLUDING LIABILITY OR WARRANTIES RELATING TO FITNESS FOR A PARTICULAR PURPOSE, CONSEQUENTIAL OR INCIDENTAL DAMAGES, MERCHANTABILITY, OR INFRINGEMENT OF ANY PATENT, COPYRIGHT OR OTHER INTELLECTUAL PROPERTY RIGHT. MACOM FURTHER DOES NOT WARRANT THE ACCURACY OR COMPLETENESS OF THE INFORMATION, TEXT, GRAPHICS OR OTHER ITEMS CONTAINED WITHIN THESE MATERIALS. MACOM SHALL NOT BE LIABLE FOR ANY SPECIAL, INDIRECT, INCIDENTAL, OR CONSEQUENTIAL DAMAGES, INCLUDING WITHOUT LIMITATION, LOST REVENUES OR LOST PROFITS, WHICH MAY RESULT FROM THE USE OF THESE MATERIALS.

MACOM products are not intended for use in medical, lifesaving or life sustaining applications. MACOM customers using or selling MACOM products for use in such applications do so at their own risk and agree to fully indemnify MACOM for any damages resulting from such improper use or sale.