

1. Mechanical Dimensions:

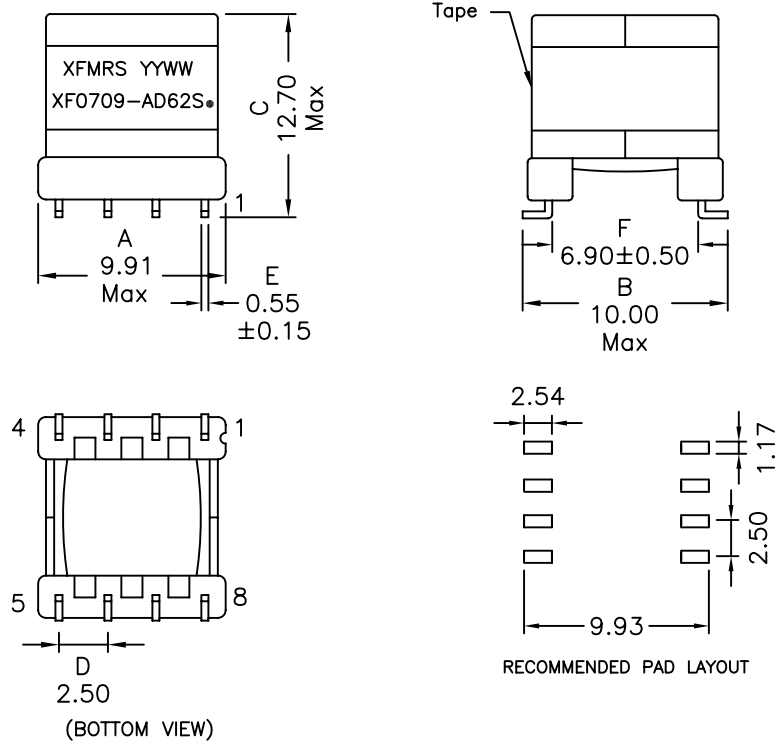

2. Schematic:

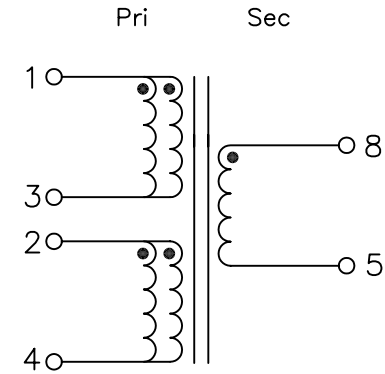

3. Electrical Specifications: @25°C

OCL: Pins 1-4 3.0mH±6% @10KHz 0.05V, Short Pins 3+2

Q: Pins 1-4 15 Min @10KHz 0.05V

Cw/w: Pins 1-8 75pF Max @100KHz 0.05V, Short Pins 2+3

LL: Pins 1-4 25uH Max @100KHz 0.05V, Short Pins 3+2,8+5

DCR: Pins 8-5 1.2 Ohms Max, for reference only

Pins 1-4 6.0 Ohms Max Short Pins 3+2 for reference only

Turns Ratio: (1-4):(8-5)=4.5:1±1% Short Pins 3+2

THD: Pins 1-4 -84dB Max @4.5KHz, 5Vrms 60mAdc

Hipot: 1800Vrms, Pins 1-3-2-4 to 8-5

Notes:

- Solderability: Leads shall meet MIL-STD-202G, Method 208H for solderability.
- Flammability: UL94V-0
- ASTM oxygen index: > 28%
- Insulation System: Class F 155°C. UL file E151556
- Operating Temperature Range: All listed parameters are to be within tolerance from -40°C to +85°C
- Storage Temperature Range: -55°C to +125°C
- Aqueous wash compatible
- SMD Lead Coplanarity: ±0.004"(0.102mm)
- Electrical and mechanical specifications 100% tested
- RoHS Compliant Component
- Designed to meet UL60950 for Supplementary Insulation for a primary working voltage of 250Vrms.

DOC. REV: A/2

XFMRS Inc www.XFMRS.com		Title: Transformer, Shdsl, SMT, 8 Pin	
UNLESS OTHERWISE SPECIFIED TOLERANCES: .xx ±0.25 Dimensions in MM		P/N: XF0709-AD62S	REV. A
SHEET 1 OF 1		DWN.	Aug-18-09
		CHK.	Aug-18-09
		APP.	Aug-18-09
		Xianyi	
		YK Liao	
		BW	