

FEATURES

- Up to 300mA Output Current(Each LDO)
- Dual Shutdown Pins Control Each Output
- 90uA Operating supply current per LDO
- Excellent Line regulation:0.05%/V
- Low Dropout:220mV@300mA
- High Power Supply Rejection Ratio
- Wide Operating Voltage Range:2.0V to 6.0V
- 1.2V to 3.3V Factory-Preset Output
- High Accuracy: $\pm 1\%$ or $\pm 2\%$
- Internal Pulled down(8 M Ω)resistor
- Current Limiting and Thermal Protection
- Two LDOs in SOT-23-6 and ESOP-8 Package
- RoHS Compliant and 100% Lead(Pb)-Free

APPLICATIONS

- Cellular and Smart Phones
- Battery-Powered Equipment
- Laptop, Palmtops, Notebook Computers
- Hand-Held Instruments
- PCMCIA Cards and Wireless LAN
- MP3/MP4/MP5 Players
- Portable Information Appliances

DESCRIPTION

The BL9180 dual, low noise, low-dropout regulator supplying up to 300mA output current at each channel. The output voltage for each regulator is set independently by trimming. Voltages are selectable in 50mV steps within a range of 1.2V to 3.3V by operating from a 2V to 6V input. The BL9180 includes two independent logic-controlled shutdown inputs and allows the output of each regulator to be turned off independently. When both outputs shutdown simultaneously, the chip will be turn off and consumes nearly zero operation current which is suitable for battery-power devices.

The BL9180 includes high accuracy voltage reference, error amplifier, current limit circuit and output driver module.

The BL9180 has excellent load and line transient response and good temperature characteristics, which can assure the stability of chip and power system. And it uses trimming technique to guarantee output voltage accuracy within $\pm 1\%$ or $\pm 2\%$. The BL9180 is available in SOT-23-6 and ESOP-8 package which is Lead(Pb)-free.

ORDERING INFORMATION

BL9180 X X X XX

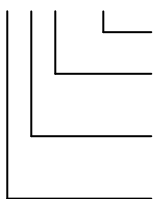

Package:
 RA:SOT-23-6A
 RB:SOT-23-6B
 EP:ESOP-8

Features:
 P:Standard(default, lead free)
 C:Customized

Output Voltage Accuracy
 A: $\pm 1\%$
 B: $\pm 2\%$

Output Voltage
 A: 1.3V(Output1),2.8V(Output2)
 B: 1.5V(Output1),3.0V(Output2)
 C: 1.8V(Output1),2.5V(Output2)
 D: 1.8V(Output1),2.8V(Output2)
 E: 2.5V(Output1),1.8V(Output2)
 F: 2.8V(Output1),1.8V(Output2)
 G: 2.8V(Output1),3.0V(Output2)
 H: 2.8V(Output1),3.3V(Output2)
 I: 3.0V(Output1),1.5V(Output2)
 J: 3.3V(Output1),2.8V(Output2)
 K: 3.3V(Output1),3.3V(Output2)
 L:2.8V(Output1),1.2V(Output2)
 M:1.8V(Output1),3.3V(Output2)
 N:1.5V(Output1),3.3V(Output2)
 O: 1.2V(Output1),3.3V(Output2)
 P: 1.2V(Output1),1.8V(Output2)

TYPICAL APPLICATION

BL9180 XXX RB

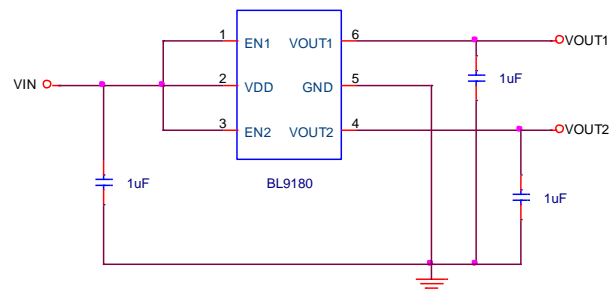

Application hints:

Output capacitor ($C_{OUT} \geq 2.2\mu F$) is recommended in BL9180 applications to assure the circuit's stability for output voltage $\leq 1.8V$.

Absolute Maximum Rating (Note 1)

Input Supply Voltage (V_{IN})	-0.3V to +7V	Maximum Junction Temperature	125°C
EN Input Voltage	-0.3V to + V_{IN}	Operating Temperature Range <small>(Note2)</small>	-40°C to 85°C
Output Voltage	-0.3V to $V_{IN}+0.3V$	Storage Temperature Range	-65°C to 125°C
Output Current	400mA	Lead Temperature (Soldering, 10s)	300°C

Package Information

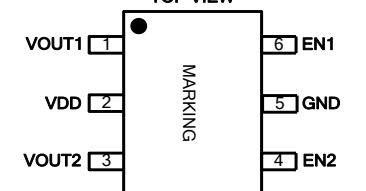
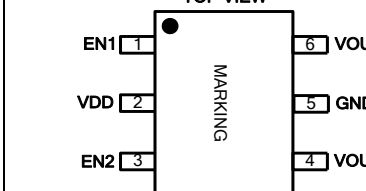
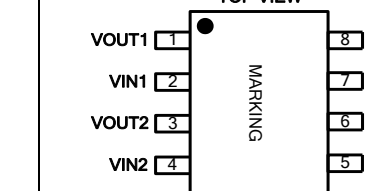
SOT-23-6A TOP VIEW	SOT-23-6B TOP VIEW	ESOP-8 TOP VIEW
		
Part Number	Top Mark	Temp Range
BL9180-XXXRA	<u>E</u> VYW <small>(Note3)</small>	-40°C to +85°C
BL9180-XXXRB	EVYW	-40°C to +85°C
BL9180-XXXEP	BL9180 VYWEP <small>(Note3)</small>	-40°C to +85°C

Pin Description

Name	Function
VOUT1	LDO1 Output Pin
VDD	Input Pin
VOUT2	LDO2 Output Pin
EN2	LDO2 Enable Pin
GND	Ground Pin
EN1	LDO1 Enable Pin1
VIN1	Input Pin1
VIN2	Input Pin2

Thermal Resistance (Note 4):

Package	Θ_{JA}	Θ_{JC}
SOT23-6	250°C/W	130°C/W
ESOP-8	50°C/W	10°C/W

Y	9	A	B	C	D
Year	2009	2010	2011	2012	2013

W	1	...	25	26	27	...	51	52
Week	A	...	Y	Z	a	...	y	z

Product Classification

Output Voltage	Voltage Code	Accuracy	Package Type	Product Name	Package Type	Product Name	Package Type	Product Name
1.3V/2.8V	A	±2%	SOT-23-6A	BL9180-ABPRA	SOT-23-6B	BL9180-ABPRB	ESOP-8	BL9180-ABPEP
1.5V/3.0V	B	±2%	SOT-23-6A	BL9180-BBPRA	SOT-23-6B	BL9180-BBPRB	ESOP-8	BL9180-BBPEP
1.8V/2.5V	C	±2%	SOT-23-6A	BL9180-CBPRA	SOT-23-6B	BL9180-CBPRB	ESOP-8	BL9180-CBPEP
1.8V/2.8V	D	±2%	SOT-23-6A	BL9180-DBPRA	SOT-23-6B	BL9180-DBPRB	ESOP-8	BL9180-DBPEP
2.5V/1.8V	E	±2%	SOT-23-6A	BL9180-EBPRA	SOT-23-6B	BL9180-EBPRB	ESOP-8	BL9180-EBPEP

2.8V/1.8V	F	±2%	SOT-23-6A	BL9180-FBPRA	SOT-23-6B	BL9180-FBPRB	ESOP-8	BL9180-FBPEP
2.8V/3.0V	G	±2%	SOT-23-6A	BL9180-GBPRA	SOT-23-6B	BL9180-GBPRB	ESOP-8	BL9180-GBPEP
2.8V/3.3V	H	±2%	SOT-23-6A	BL9180-HBPRA	SOT-23-6B	BL9180-HBPRB	ESOP-8	BL9180-HBPEP
3.0V/1.5V	I	±2%	SOT-23-6A	BL9180-IBPRA	SOT-23-6B	BL9180-IBPRB	ESOP-8	BL9180-IBPEP
3.3V/2.8V	J	±2%	SOT-23-6A	BL9180-JBPRA	SOT-23-6B	BL9180-JBPRB	ESOP-8	BL9180-JBPEP
3.3V/3.3V	K	±2%	SOT-23-6A	BL9180-KBPRA	SOT-23-6B	BL9180-KBPRB	ESOP-8	BL9180-KBPEP
2.8V/1.2V	L	±2%	SOT-23-6A	BL9180-LBPRA	SOT-23-6B	BL9180-LBPRB	ESOP-8	BL9180-LBPEP
1.8V/3.3V	M	±2%	SOT-23-6A	BL9180-MBPRA	SOT-23-6B	BL9180-MBPRB	ESOP-8	BL9180-MBPEP
1.5V/3.3V	N	±2%	SOT-23-6A	BL9180-NBPRA	SOT-23-6B	BL9180-NBPRB	ESOP-8	BL9180-NBPEP
1.2V/3.3V	O	±2%	SOT-23-6A	BL9180-OBPRA	SOT-23-6B	BL9180-OBPRB	ESOP-8	BL9180-OBPEP
1.2V/1.8V	P	±2%	SOT-23-6A	BL9180-PBPRA	SOT-23-6B	BL9180-PBPRB	ESOP-8	BL9180-PBPEP

Note 1: Absolute Maximum Ratings are those values beyond which the life of a device may be impaired.

Note 2: The BL9180 is guaranteed to meet performance specifications from 0°C to 70°C. Specifications over the -40°C to 85°C operating temperature range are assured by design, characterization and correlation with statistical process controls.

Note 3: E: BL9180 with RA package E: BL9180 with RB package V: Voltage code Y: Year of wafer manufacturing W: Week of wafer manufacturing EP: ESOP-8

Note 4: Thermal Resistance is specified with approximately 1 square of 1 oz copper.

Block Diagram

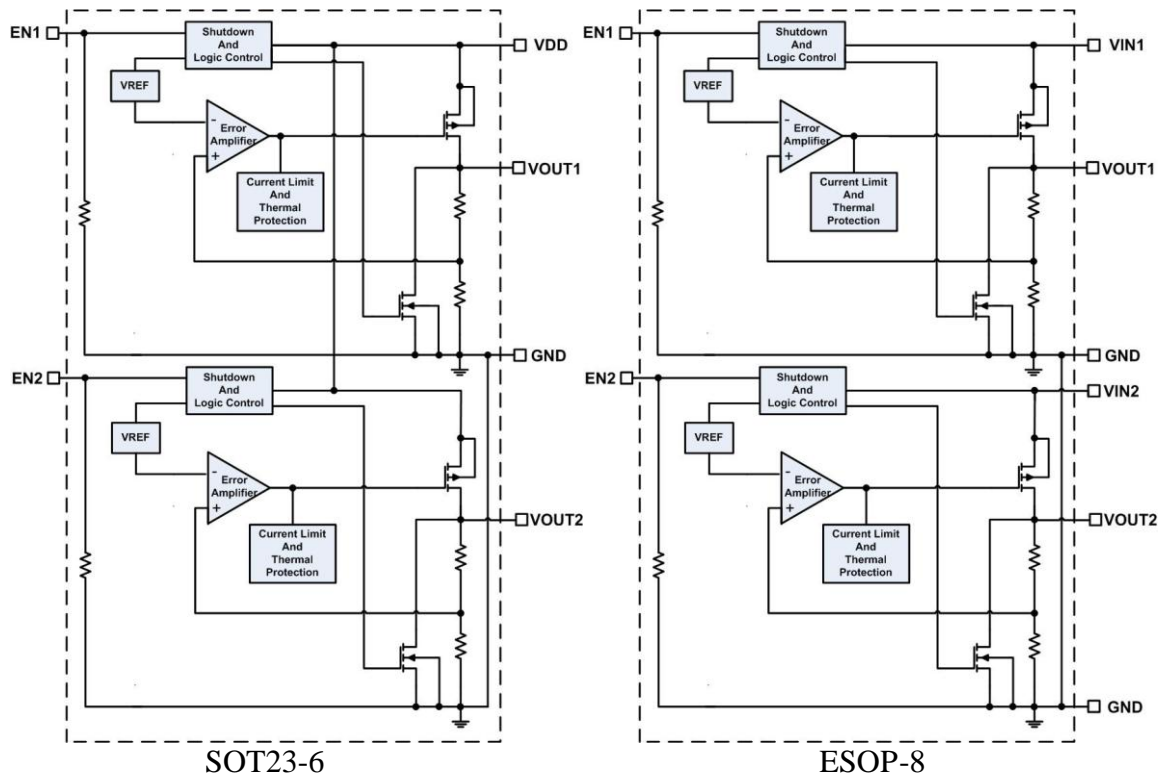

Electrical Characteristics (Note 5)

 ($V_{IN}=3.6V$, $EN1=EN2=V_{IN}$, $C_{IN}=C_{OUT}=1\mu F$, $T_A=25^\circ C$, unless otherwise noted.)

Parameter		Symbol	Conditions	MIN	TYP	MAX	unit
Input Voltage		V_{IN}		2		6	V
Output Voltage Accuracy (Note 6)		ΔV_{OUT}	$V_{IN}=3.6V$, $I_{OUT}=1mA$	-1 -2		+1 +2	%
Current Limit		I_{LIM}	$R_{LOAD}=1\Omega$	400	430		mA
Quiescent Current		I_Q	$V_{EN}>1.2V$, $I_{OUT}=0mA$		180	260	μA
Dropout Voltage		V_{DROP}	$I_{OUT}=200mA$, $V_{OUT}=2.8V$		130	180	mV
			$I_{OUT}=300mA$, $V_{OUT}=2.8V$		210	300	
Line Regulation (Note 7)		ΔV_{LINE}	$V_{IN}=3.6V$ to $5.5V$ $I_{OUT}=1mA$		0.05	0.17	%/V
Load Regulation (Note 8)		ΔV_{LOAD}	$1mA < I_{OUT} < 300mA$			2	%/A
Output Voltage Temperature Coefficient (Note 9)		TC_{VOUT}	$I_{OUT}=1mA$		± 60		ppm/ $^\circ C$
Standby Current		I_{STBY}	$V_{EN}=GND$, Shutdown		0.01	1	μA
EN Input Bias Current		I_{IBSD}	$V_{EN}=GND$ or V_{IN}		0	100	nA
EN Input Threshold	Logic Low	V_{IL}	$V_{IN}=3V$ to $5.5V$, Shutdown			0.4	V
	Logic High	V_{IH}	$V_{IN}=3V$ to $5.5V$, Start up	1.2			V
Output Noise Voltage		e_{NO}	10Hz to 100KHz, $I_{OUT}=200mA$ $C_{OUT}=1\mu F$		100		μV_{RMS}
Power Supply Rejection Ratio	$f=217Hz$	PSRR	$I_{OUT}=100mA$		-73		dB
	$f=1KHz$				-70		
	$f=10KHz$				-50		
Thermal Shutdown Temperature		T_{SD}	Shutdown, Temp increasing		165		$^\circ C$
Thermal Shutdown Hysteresis		T_{SDHY}			30		$^\circ C$

Note 5: 100% production test at $+25^\circ C$. Specifications over the temperature range are guaranteed by design and characterization.

Note 6: This IC includes two kinds of output voltage accuracy versions. A: $\pm 1\%$, B: $\pm 2\%$.

Note 7: Line regulation is calculated by
$$\Delta V_{LINE} = \left(\frac{V_{OUT1} - V_{OUT2}}{\Delta V_{IN} \times V_{OUT(normal)}} \right) \times 100$$

Where V_{OUT1} is the output voltage when $V_{IN}=5.5V$, and V_{OUT2} is the output voltage when $V_{IN}=3.6V$, $\Delta V_{IN}=1.9V$. $V_{OUT(normal)}=2.8V$.

Note 8: Load regulation is calculated by
$$\Delta V_{LOAD} = \left(\frac{V_{OUT1} - V_{OUT2}}{\Delta I_{OUT} \times V_{OUT(normal)}} \right) \times 100$$

Where V_{OUT1} is the output voltage when $I_{OUT}=1mA$, and V_{OUT2} is the output voltage when $I_{OUT}=300mA$. $\Delta I_{OUT}=0.299A$, $V_{OUT(normal)}=2.8V$.

Note 9: The temperature coefficient is calculated by
$$TC_{VOUT} = \frac{\Delta V_{OUT}}{\Delta T \times V_{OUT}}$$

Typical Performance Characteristics

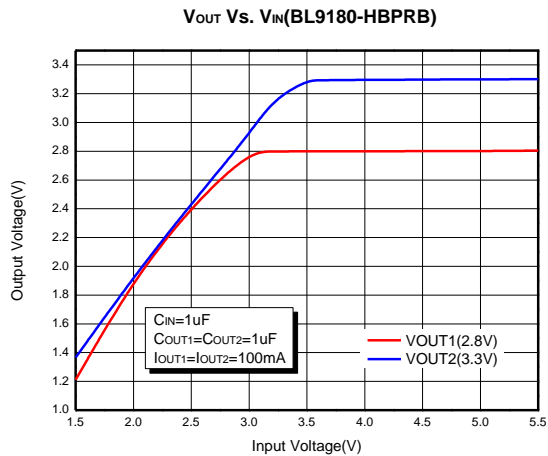
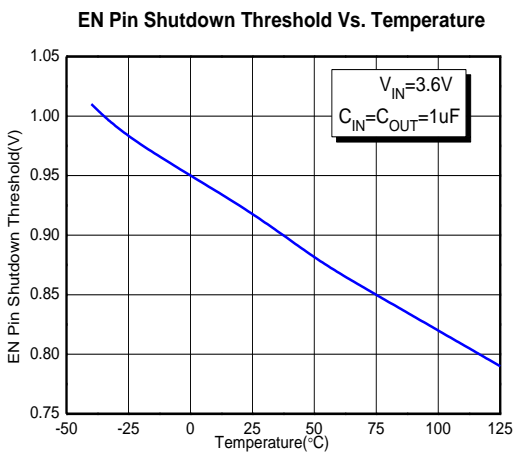
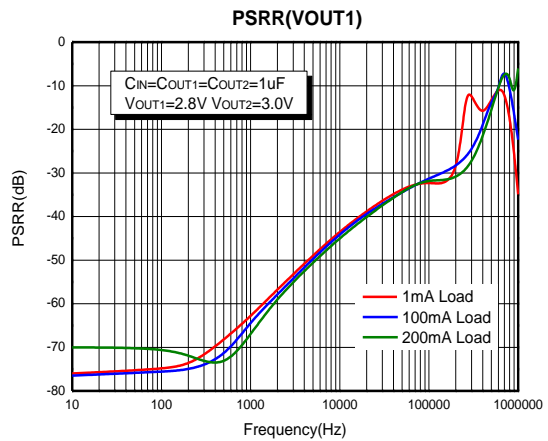
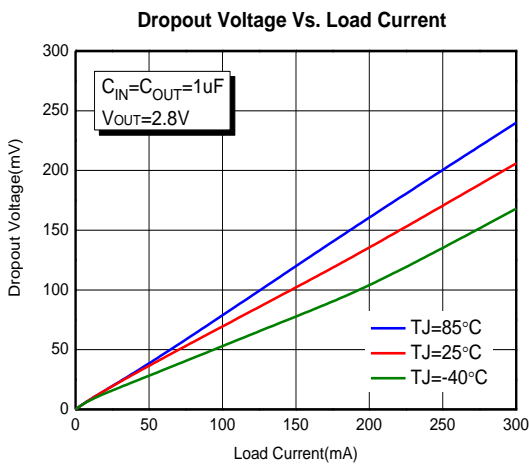
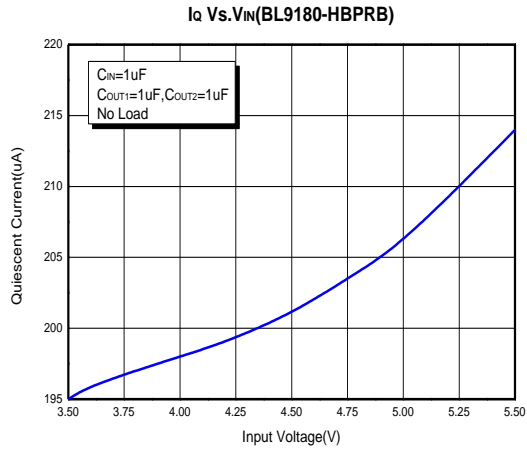
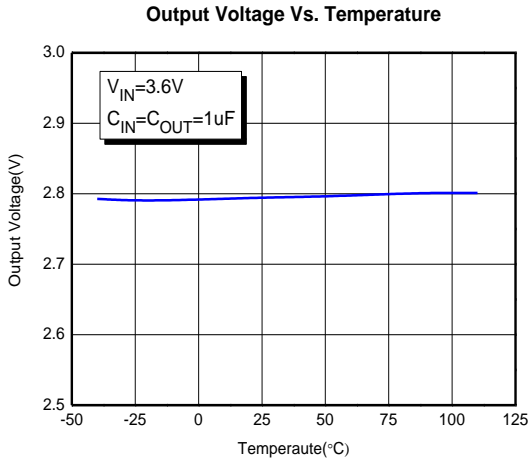

Load Transient

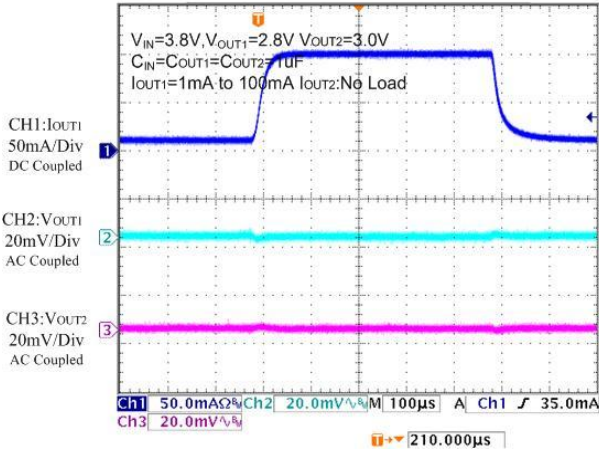

Load Transient

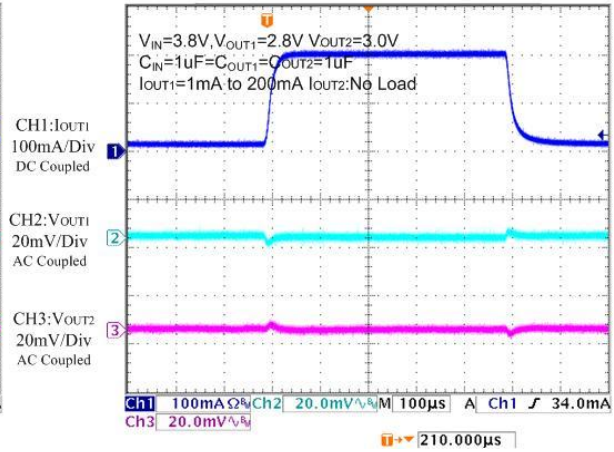

Line Transient

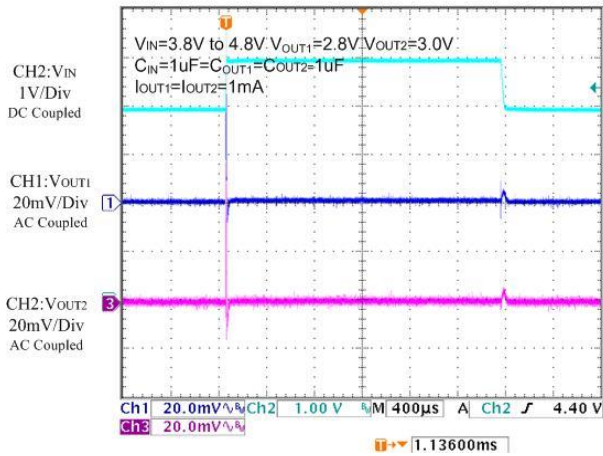

Line Transient

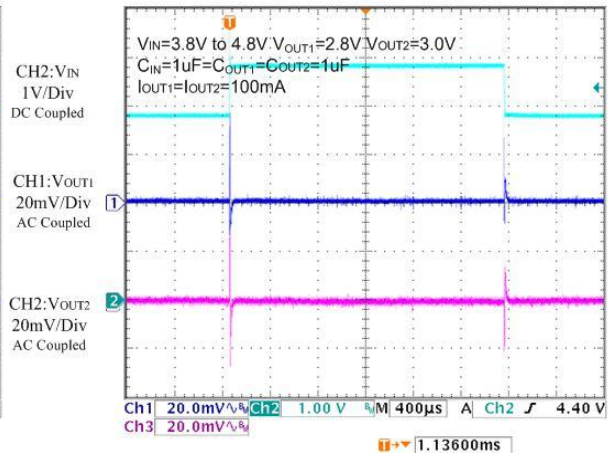

Start up

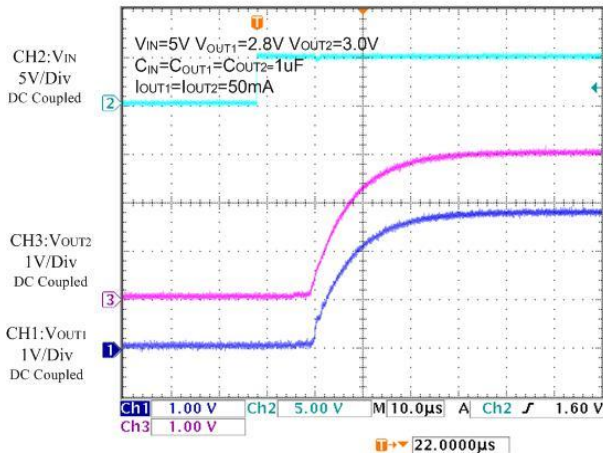

EN Pin Shutdown Response

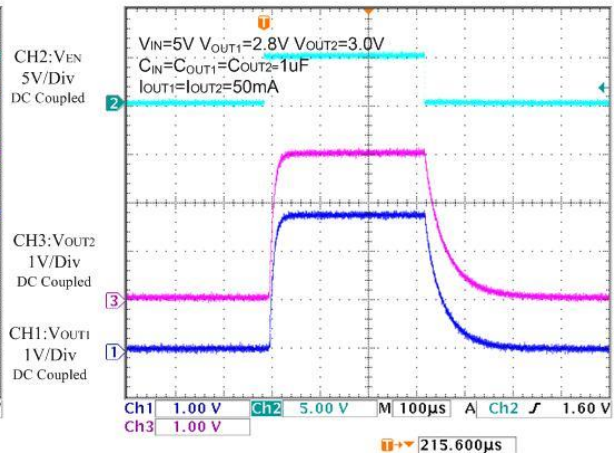

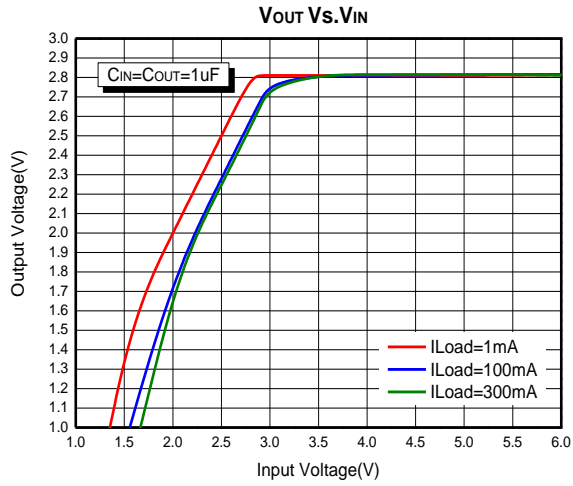

Applications Information

The BL9180 is integrated with two low noise, low dropout and low quiescent current linear regulators designed primarily for battery applications. Output voltages are optional ranging from 1.2V to 3.3V, and each channel can supply current up to 300 mA.

Enable Function

The BL9180 is shutdown by pulling the EN input low, and turn on by driving the input high. If this feature is not be used, the EN input should be tied to VIN to keep the regulator on at all times.

Current Limit and Thermal Protection

The BL9180 includes two independent current limit structure which monitor and control each pass transistor's gate voltage limiting the guaranteed maximum output current to 300mA. Thermal overload protection limits total power dissipation in the BL9180. When the junction temperature exceeds $T_J=165^{\circ}\text{C}$, the OTP circuit starts the thermal shutdown function turn the pass element off and allowing the IC to cool. The OTP circuit turn on the pass element again after IC's junction temperature cool by 30°C , result in a pulsed output during continuous thermal overload conditions. Thermal-overloaded protection is designed to protect the BL9180 in the event of fault conditions. Do not exceed the absolute maximum junction temperature rating of $T_J=125^{\circ}\text{C}$ for continuous operation. The output can be shorted to ground for an indefinite amount of time without damaging the part by cooperation of current limit and thermal

protection.

Operating Region and Power Dissipation

The maximum power dissipation of BL9180 depends on the thermal resistance of the case and circuit board, the temperature difference between the die junction and ambient air, and the rate of airflow. The power dissipation across the device is

$$P_D = (V_{IN} - V_{OUT}) \times I_{OUT} + V_{IN} \times I_Q$$

The maximum power dissipation is:

$$P_D(\text{MAX}) = (T_J(\text{MAX}) - T_A) / \theta_{JA}$$

Where $T_J(\text{MAX})$ is the maximum operation junction temperature 125°C , T_A is the ambient temperature and the θ_{JA} is the junction to ambient thermal resistance. The GND pin of the BL9180 performs the dual function of providing an electrical connection to ground and channeling heat away. Connect the GND pin to ground using a large pad or ground plane.

Capacitor Selection and Regulator Stability

Like any low-dropout regulator, the external capacitors used with the BL9180 must be carefully selected for regulator stability and performance. The BL9180 requires an output capacitor between the VOUT and GND pins for phase compensation. Using a capacitor whose value is $> 1\mu\text{F}$ on the BL9180 input and the amount of

capacitance can be increased without limit. The input capacitor must be located a distance of not more than 0.5 inch from the input pin of the IC and returned to a clean analog ground. Any good quality ceramic or tantalum can be used for this capacitor. The capacitor with larger value and lower ESR (equivalent series resistance) provides better PSRR and line-transient response. The output capacitor must meet both requirements for minimum amount of capacitance and ESR in all LDOs applications. The BL9180 is designed specifically to work with low ESR ceramic output capacitor in space-saving and performance consideration. Using a ceramic capacitor whose value is at least 1 μ F with ESR is > 5m Ω on the BL9180 output ensures stability. The BL9180 still works well with output capacitor of other types due to the wide stable ESR range. Output capacitor of larger capacitance can reduce noise and improve load transient response, stability, and PSRR. The output capacitor should be located not more than 0.5 inch from the V_{OUT} pin of the BL9180 and returned to a clean analog ground.

Load-Transient Considerations

The BL9180 load-transient response graphs show two components of the output response: a DC shift from the output

impedance due to the load current change, and the transient response. The DC shift is quite small due to the excellent load regulation of the IC. Typical output voltage transient spike for a step change in the load current from 0mA to 50mA is tens of mV, depending on the ESR of the output capacitor. Increasing the output capacitor's value and decreasing the ESR attenuates the overshoot.

Input-Output (Dropout) Voltage

A regulator's minimum input-output voltage differential (or dropout voltage) determines the lowest usable supply voltage. In battery-powered systems, this will determine the useful end-of-life battery voltage. Because the BL9180 uses a P-Channel MOSFET pass transistor, the dropout voltage is a function of drain-to-source on resistance [$R_{DS(ON)}$] multiplied by the load current.

Layout Considerations

To improve ac performance such as PSRR, output noise, and transient response, it is recommended that the PCB be designed with separate ground planes for V_{IN} and V_{OUT}, with each ground plane connected only at the GND pin of the device.

BL9180 Layout Circuit

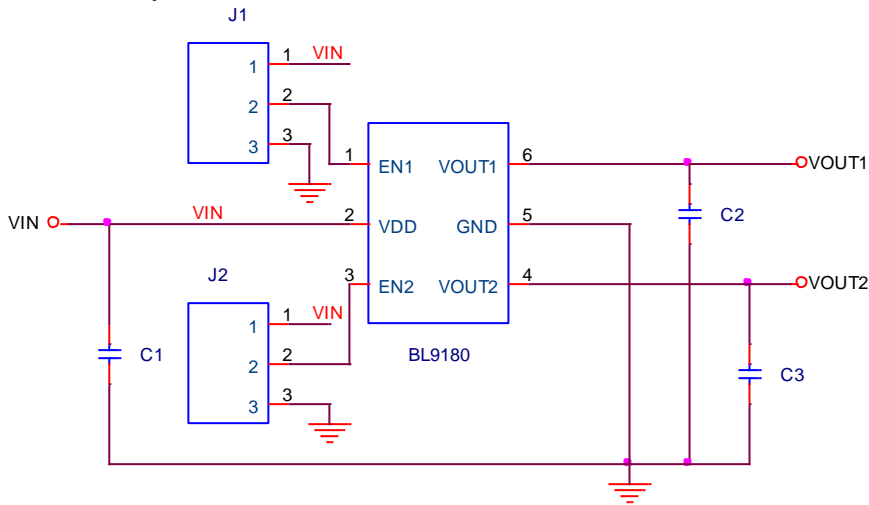

Top Layer Layout

Bottom Layer Layout

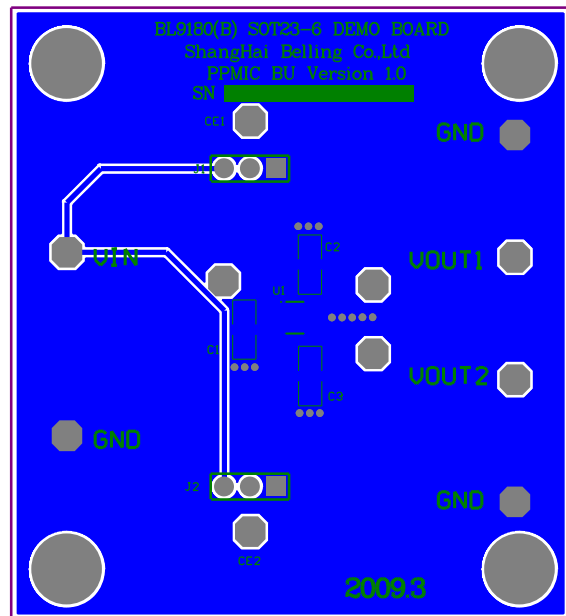
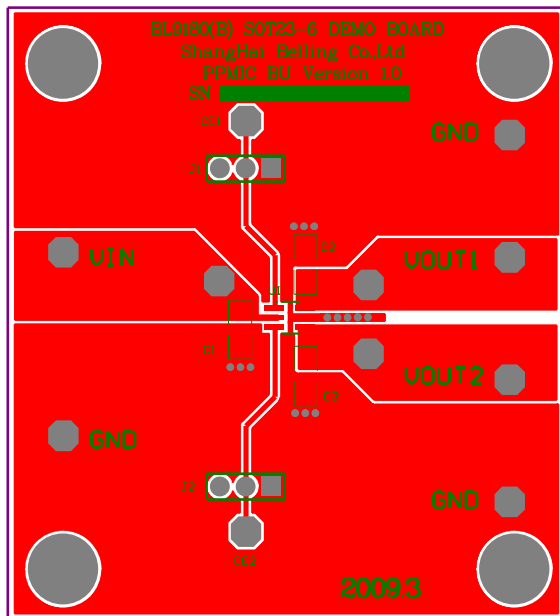

Package Description

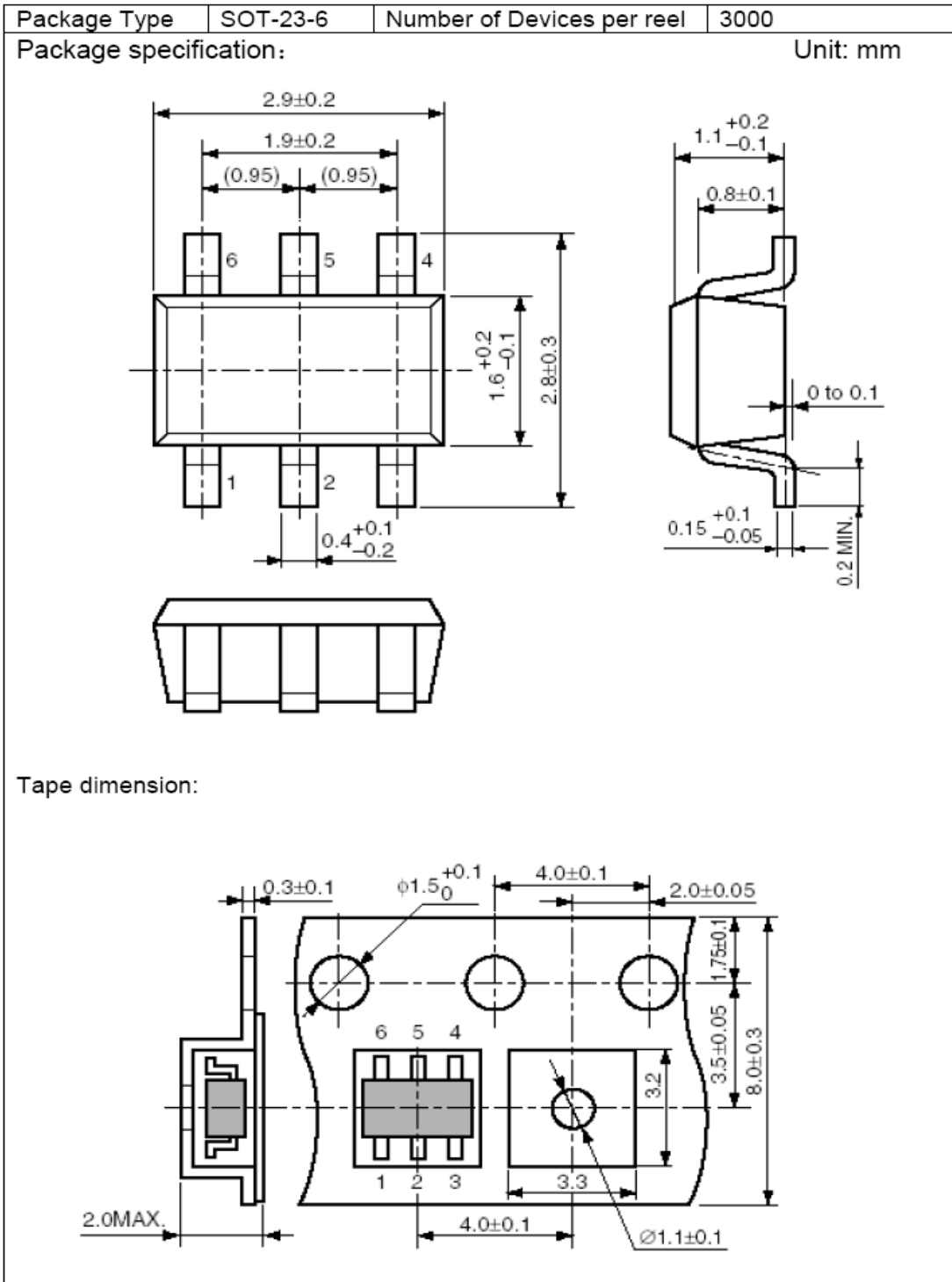

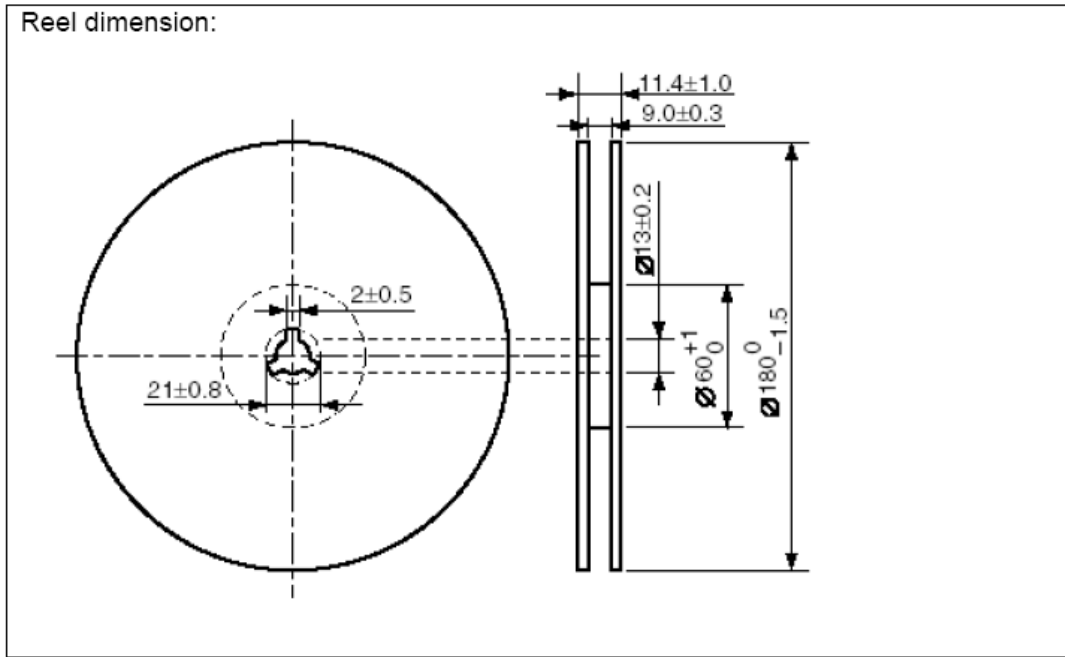

ESOP-8

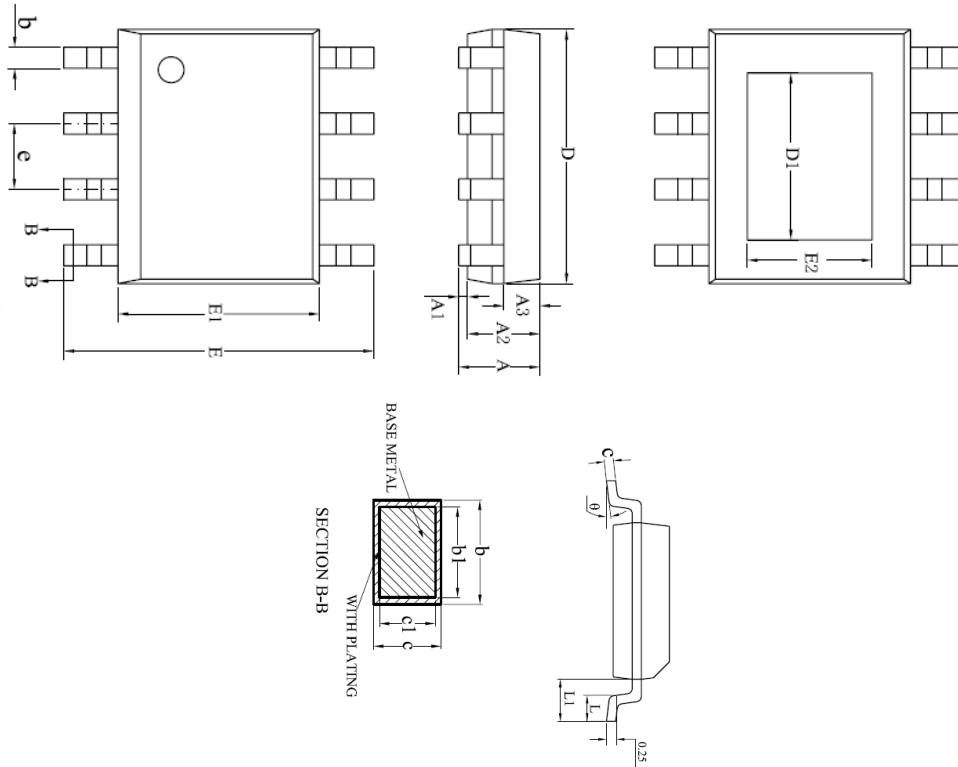

Symbol	Dimensions In Millimeters		
	Min	NOM	Max
A			1.77
A1	0.08	0.18	0.28
A2	1.2	1.4	1.6
A3	0.55	0.65	0.75
b	0.39		0.48
b1	0.38	0.41	0.43
c	0.21		0.26
c1	0.19	0.2	0.21
D	4.7	4.9	5.1
E	5.8	6	6.2
E1	3.7	3.9	4.1
e	1.27BSC		
L	0.5	0.65	0.8
L1	1.05BSC		
Θ	0		8°
D1	3.30REF		
E2	2.40REF		

ESOP-8 Surface Mount Package