

## HYBRID - HIGH RELIABILITY RADIATION TOLERANT DC-DC CONVERTER

### AMR28XXS SERIES 28V Input, Single Output

#### Description

The AMR28XXS series of DC-DC converter modules has been specifically designed for operation in moderate radiation environments supplementing the higher radiation performance available in the International Rectifier ART2815T converter series. Environments presented to space vehicles operating in low earth orbits, launch boosters, orbiting space stations and similar applications requiring a low power, high performance converter with moderate radiation hardness performance will be optimally served by the AMR28XXS Series.

The physical configuration of the AMR28XXS series permits mounting directly to a heat conduction surface without the necessity of signal leads penetrating the heat sink surface. This package configuration permits greater independence in mounting and more secure mechanical attachment than traditional radially leaded packages. International Rectifier's rugged ceramic seal pins are used exclusively in the package thereby assuring long term hermeticity.

The AMR28XXS has been designed for high density using chip and wire hybrid technology that complies with the class H requirements of MIL-PRF-38534. Manufactured in a facility fully qualified to MIL-PRF-38534, these converters are fabricated utilizing DSCC qualified processes. For available screening options, refer to device screening table in the data sheet. Applicable generic lot qualification test data including radiation performance can be made available on request. Consult IR San Jose for special requirements.

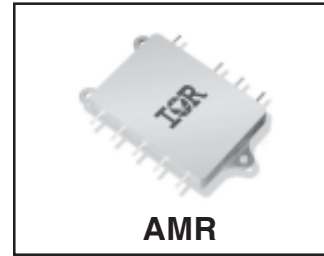

#### Features

- 30 Watts Output Power
- Available in 3.3, 5, 12 and 15 Volt Outputs
- 18 - 40 VDC Input Range (28 VDC Nominal)
- Total Ionizing Dose > 25KRads (Si)
- SEE Hardened to LET up to 60 MeV.cm<sup>2</sup>/mg
- -55°C to +125°C Operating Range
- Indefinite Short Circuit Protection
- External Synchronization
- Shutdown from External Signal
- Flexible Mounting
- Fully Isolated - Input to Output and to Case
- Complimentary EMI Filter Available
- Electrical Performance Similar to ATR28XXS Series
- Standard Microcircuit Drawings Available

Specifications

Absolute Maximum Ratings		Recommended Operating Conditions	
Input Voltage range	-0.5V to +50VDC (Continuous), 80V (100ms)	Input Voltage range	+16V to +40VDC
Soldering temperature	300°C for 10 seconds	Output Power	Less than or equal to 30W
Storage case temperature	-65°C to +135°C	Operating case temperature	-55°C to +125°C

**Static Characteristics**  $-55^{\circ}\text{C} \leq T_{\text{CASE}} \leq +125^{\circ}\text{C}$ ,  $V_{\text{IN}}=28 \text{ V}_{\text{DC}} \pm 5\%$ ,  $C_L=0$ , unless otherwise specified.

Parameter	Group A Subgroups	Test Conditions	Min	Nom	Max	Unit
<b>Input Voltage</b>			16	28	40	V
<b>Output Voltage</b>		$I_{\text{out}}=0$				
AMR2803R3S	1		3.25	3.30	3.35	V
AMR2805S	1		4.95	5.00	5.05	
AMR2812S	1		11.88	12.00	12.12	
AMR2815S	1		14.85	15.00	15.15	
AMR2803R3S	2, 3		3.20		3.40	
AMR2805S	2, 3		4.90		5.10	
AMR2812S	2, 3		11.70		12.30	
AMR2815S	2, 3		14.60		15.40	
<b>Output Current</b> <sup>1</sup>		$V_{\text{in}} = 18, 28, 40 \text{ Volts}$				
AMR2803R3S	1, 2, 3				7500	mA
AMR2805S	1, 2, 3				6000	
AMR2812S	1, 2, 3				2500	
AMR2815S	1, 2, 3				2000	
<b>Output Power</b>		100% load				
AMR2803R3S	1, 2, 3				25	W
All Others	1, 2, 3				30	
<b>Output Ripple Voltage</b> <sup>2</sup>		$V_{\text{in}} = 18, 28, 40 \text{ Volts}$ $\text{BW} = 20 \text{ Hz to } 2 \text{ MHz}$				
AMR2803R3S	1, 2, 3				60	mV <sub>PP</sub>
AMR2805S	1, 2, 3				60	
AMR2812S	1, 2, 3				60	
AMR2815S	1, 2, 3				75	
<b>Output Voltage Regulation</b> <sup>3</sup>		$V_{\text{in}} = 18, 28, 40 \text{ Volts}$ $I_{\text{out}} = 0, 50\%, \text{ and } 100\% \text{ load}$				
<b>Line</b>						mV
AMR2803R3S	1, 2, 3				±10	
AMR2805S	1, 2, 3				±10	
AMR2812S	1, 2, 3				±30	
AMR2815S	1, 2, 3				±60	
					±40	
					±75	
<b>Load</b>						
AMR2803R3S	1, 2, 3				±10	
AMR2805S	1, 2, 3				±10	
AMR2812S	1, 2, 3				±50	
AMR2815S	1, 2, 3				±120	
					±50	
					±150	

For Notes to Specifications, refer to page 4

**Static Characteristics** (Continued)  $-55^{\circ}\text{C} \leq T_{\text{CASE}} \leq +125^{\circ}\text{C}$ ,  $V_{\text{IN}}=28 \text{ V}_{\text{DC}} \pm 5\%$ ,  $C_{\text{L}}=0$ , unless otherwise specified.

Parameter	Group A Subgroups	Test Conditions	Min	Nom	Max	Unit
<b>Input Current</b> No Load	AMR2803R3S	Iout=0, Inhibit =open		20	50	mA
	AMR2805S					
	AMR2812S					
	AMR2815S					
Inhibited	All	Inhibit shorted to input return		8.0	18	
<b>Input Ripple Current</b> <sup>2</sup>	1, 2, 3	Vin = 16, 28, 40 Volts, 100% load, BW = 20 Hz to 2 MHz			50	mA <sub>PP</sub>
<b>Efficiency</b>	AMR2803R3S	100% load				%
	AMR2805S					
	AMR2812S					
	AMR2815S					
	AMR2803R3S					
	AMR2805S					
	AMR2812S					
	AMR2815S					
<b>Isolation</b>	1	Input to output or any pin to case (except case ground pin) at 500Vdc	100			MΩ
<b>Capacitive Load</b> <sup>4,5</sup>	4	No effect on dc performance			500	μF
<b>Short Circuit Power Dissipation</b>	1, 2, 3				19	W
<b>Switching Frequency</b>	4, 5, 6	100% load	500	550	600	KHz
<b>Sync Frequency Range</b>	4, 5, 6	100% load	500		700	KHz
<b>MTBF</b>		MIL-HDBK-217F, N2 SF @ Tc = 35°C	940			Khrs
<b>Weight</b>					68	g

For Notes to Specifications, refer to page 4

**Dynamic Characteristics** -55°C ≤ T<sub>CASE</sub> ≤ +125°C, V<sub>IN</sub>=28 V<sub>DC</sub> ±5%, C<sub>L</sub>=0, unless otherwise specified.

Parameter	Group A Subgroups	Test Conditions	Min	Nom	Max	Unit
<b>Output Response To Step Transient Load Changes</b> <sup>7</sup>						
AMR2803R3S		Load step 50% ⇔ 100%	-500		+500	mVpk
AMR2805S	4, 5, 6		-500		+500	
AMR2812S	4, 5, 6		-800		+800	
AMR2815S	4, 5, 6		-1000		+1000	
AMR2803R3S		Load step 8% ⇔ 50%	-500		+500	
AMR2805S	4, 5, 6		-500		+500	
AMR2812S	4, 5, 6		-1000		+1000	
AMR2815S	4, 5, 6		-1000		+1000	
<b>Recovery Time, Step Transient Load Changes</b> <sup>7, 8</sup>	4, 5, 6	Load step 50% ⇔ 100% or Load step 8% ⇔ 50%			200	µs
<b>Output Response Transient Step Line Changes</b> <sup>5, 9</sup>						
AMR2803R3S	4, 5, 6	Input step from/to 18 to 40Vdc, 100% load	-500		+500	mVpk
AMR2805S	4, 5, 6		-500		+500	
AMR2812S	4, 5, 6		-1200		+1200	
AMR2815S	4, 5, 6		-1500		+1500	
<b>Recovery Time Transient Step Line Changes</b> <sup>5, 8, 9</sup>	4, 5, 6	Input step from/to 18 to 40Vdc, 100% load			10	ms
<b>Turn On Overshoot</b>						
AMR2803R3S	4, 5, 6	0% load to 100% load			500	mVpk
AMR2805S	4, 5, 6				500	
AMR2812S	4, 5, 6				800	
AMR2815S	4, 5, 6				1000	
<b>Turn On Delay</b> <sup>10</sup>	4, 5, 6	0% load to 100% load			25	ms
<b>Short Circuit Recovery</b> <sup>5, 10</sup>	4, 5, 6				25	ms

Notes to Specifications

- Parameter guaranteed by line and load regulation tests.
- Bandwidth guaranteed by design. Tested for 20 KHz to 2.0MHz.
- Output voltage measured at load with remote sense leads connected across load.
- Capacitive load may be any value from 0 to the maximum limit without compromising dc performance. A capacitive load in excess of the maximum limit will not disturb loop stability but may interfere with the operation of the load fault detection circuitry, appearing as a short circuit during turn on.
- Parameter shall be tested as part of design characterization and after design or process changes. Parameters shall be guaranteed to the limit specified in Electrical Specifications.
- Load step transition time between 2.0µs and 10µs.
- Recovery time is measured from the initiation of the transient to where V<sub>OUT</sub> has returned to within ±1 % of V<sub>OUT</sub> at 50 % load.
- Input step transition time between 2.0 and 10 microseconds.
- Turn on delay time measurement is for either a step application of power at the input or the removal of a ground signal from the inhibit pin while power is applied to the input.

Block Diagram

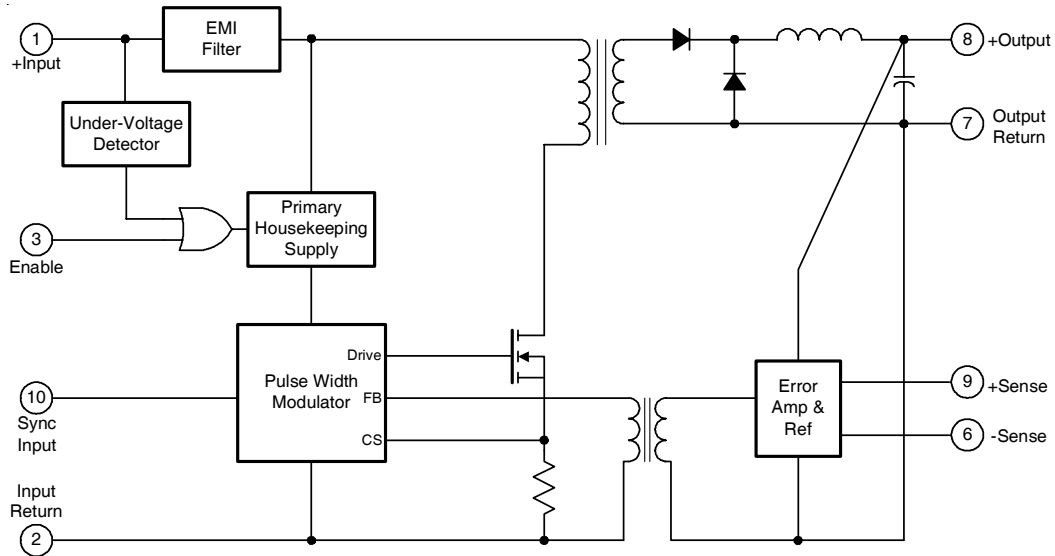

Application Information

Inhibit Function (Enable)

Connecting the inhibit input to input common will cause the converter to shut down. It is recommended that the inhibit pin be driven by an open collector device capable of sinking at least 400  $\mu$ A of current. The open circuit voltage of the inhibit input is 10 +1.0 V<sub>DC</sub>.

EMI Filter

An optional EMI filter is available (AFH461) that will reduce the input ripple current to levels below the limits imposed by MIL-STD-461 CE03.

Device Synchronization

When multiple DC/DC converters are utilized in a single system, significant low frequency noise may be generated due to a small difference in the switching frequency of the converters (beat frequency noise). Because of the low frequency nature of this noise (typically less than 10 KHz), it is difficult to filter out and may interfere with proper operation of sensitive systems (communication, radar or telemetry). International Rectifier provides synchronization of multiple AMR type converters to match switching frequency of the converter to the frequency of the system clock, thus eliminating this type of noise.

MTBF vs Case Temperature for AMR2803R3S

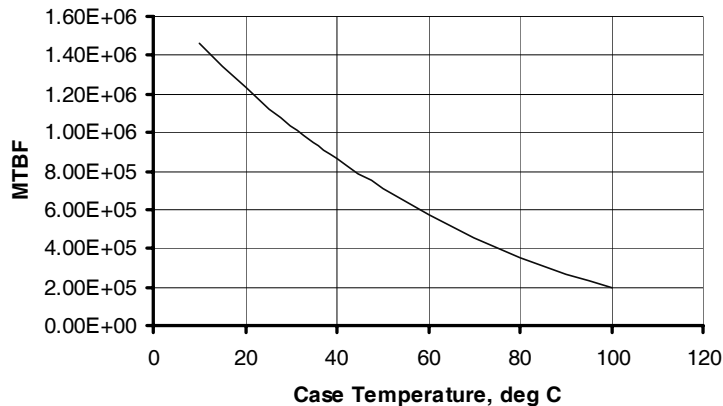

Mechanical Outline

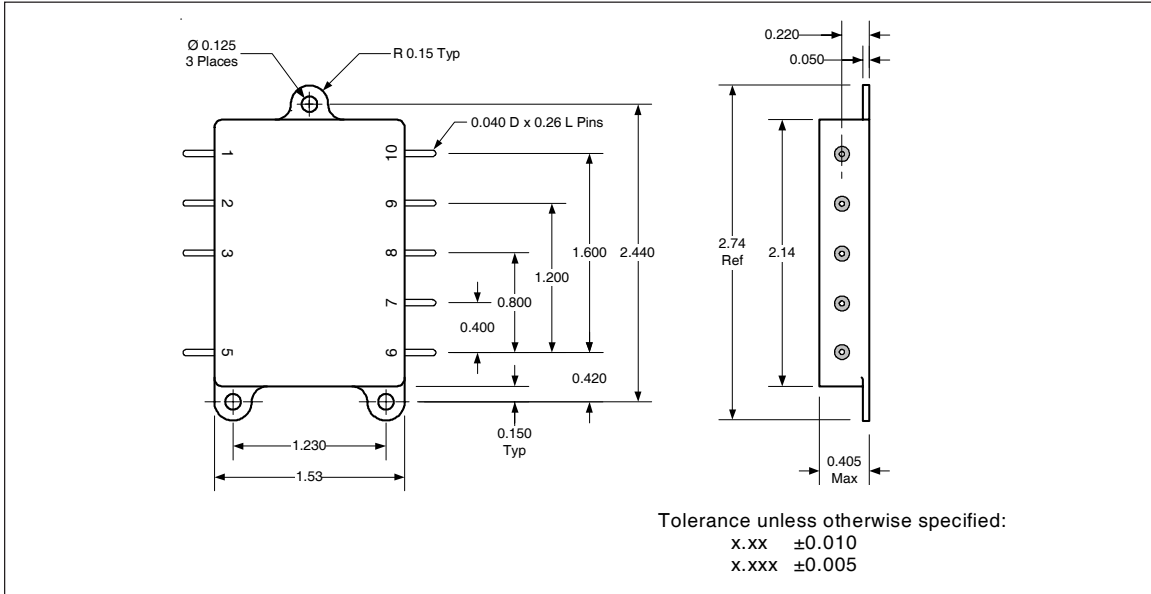

Pin Designation

Pin #	Designation
1	+ Input
2	Input Return
3	Enable
4	Blank
5	Case Ground
6	Sense Return
7	Output Return
8	+ Output
9	+ Sense
10	Sync Input

Radiation Specification

Parameter	Conditions	Min	Typ	Max	Unit
Total Ionizing Dose	MIL-STD-883, Method 1019.4 Operating bias applied during exposure	30	—	—	KRads (Si)
Heavy Ion (Single event effects)	BNL Dual Van de Graf Generator	60	—	—	MeV•cm <sup>2</sup> /mg

International Rectifier currently does not have a DSCC certified Radiation Hardness Assurance Program.

**Device Screening**

Requirement	MIL-STD-883 Method	No Suffix ②	CH ②	EM
Temperature Range	—	-55°C to +125°C	-55°C to +125°C	-55°C to +85°C
Element Evaluation	MIL-PRF-38534	Class H	Class H	N/A
Non-Destructive Bond Pull	2023	N/A	N/A	N/A
Internal Visual	2017	Yes	Yes	①
Temperature Cycle	1010	Cond C	Cond C	Cond C
Constant Acceleration	2001, Y1 Axis	3000 Gs	3000 Gs	3000 Gs
PIND	2020	Cond A	Cond A	N/A
Burn-In	1015	320 hrs @ 125°C ( 2 x 160hrs )	320 hrs @ 125°C ( 2 x 160hrs )	48 hrs @ 125°C
Final Electrical ( Group A )	MIL-PRF-38534 & Specification	-55°C, +25°C, +125°C	-55°C, +25°C, +125°C	-55°C, +25°C, +85°C
PDA	MIL-PRF-38534	2%	2%	N/A
Seal, Fine and Gross	1014	Cond A, C	Cond A, C	Cond A
Radiographic	2012	Yes	Yes	N/A
External Visual	2009	Yes	Yes	①

Notes:

- ① Best commercial practice.
  - ② Device with 'CH' suffix is a DSCC class H compliant without radiation performance. No suffix is a radiation rated device but not available as a DSCC qualified SMD per MIL-PRF-38534.
- International Rectifier currently does not have a DSCC certified Radiation Hardness Assurance Program.

**Standard Microcircuit Drawing Equivalence Table**

Standard Microcircuit Drawing Number	IR Standard Part Number
5962-04245	AMR2803R3S
5962-04246	AMR2805S

