

AAT2077B2 Preliminary Data Sheet

75Ω Digital Attenuator 2-Bit 21 dB DC~1200 MHz

1. Product Overview

1.1 General Description

The AAT2077B2 is a GaAs MMIC two bit positive control digital attenuator. The device operates from DC to 1200 MHz with a control and supply voltage of +3 V or +5 V. The AAT2077B2 has LSB of 7 dB and a total attenuation of 21dB. The AAT2077B2 is composed of two cascade fixed attenuators. The states of attenuator are controlled by the logic level voltage. The attenuator bit values are 7 dB (LSB), 14 dB for a total attenuation of 21 dB. Attenuation accuracy is $\pm(0.5 \text{ dB} + 10 \% \text{ of attenuation setting}) @ \text{DC}\sim 1200 \text{ MHz}$.

1.2 Features

- 75 Ω Impedance
- Attenuation: 21 dB with 7 dB LSB
- Attenuation Accuracy:
 $\pm (0.5 \text{ dB} + 10 \% \text{ of Atten. setting}) @ \text{DC}\sim 1200 \text{ MHz}$

1.3 Applications

- Telecommunication System
- CATV and FTTH

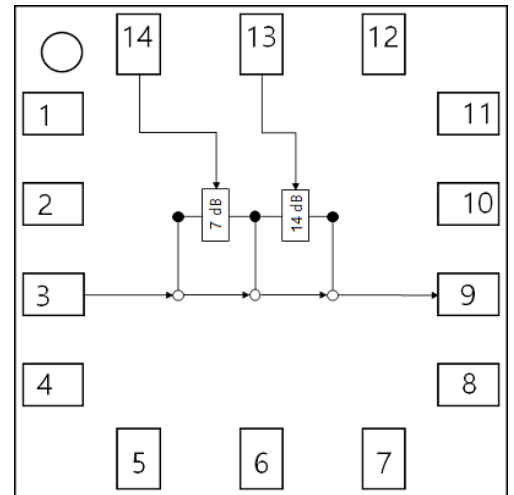

AAT2077B2 Block Diagram (X-ray view)

1.4 Package Profile & RoHS Compliance

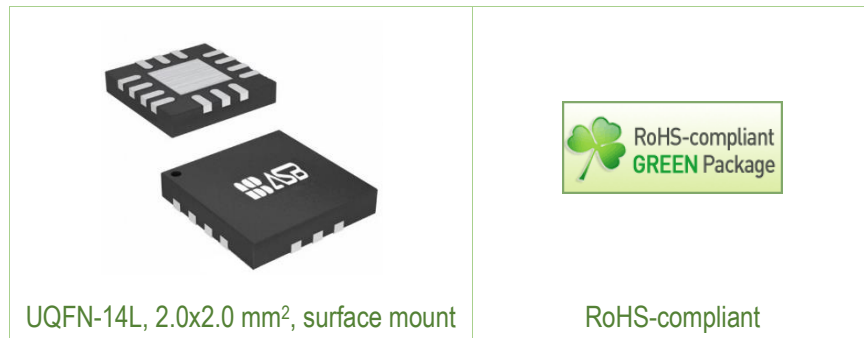

2. Summary on Product Performances

2.1 Electrical Specifications

Supply voltage = +5 V, T_A = +25 °C, Z_O = 75 Ω.

Parameter	Test Condition	Min	Typ	Max	Unit
Reference Insertion Loss (IL)	50 MHz		0.4		
	500 MHz	-	0.6	-	dB
	1200 MHz		0.7		
Attenuation Accuracy ¹⁾	DC – 1200 MHz	±(0.5 dB + 10% of attenuation setting)			
Return Loss	DC – 1200 MHz	15	16	-	dB
Switching Characteristics:					
Rise/fall Time	(10% to 90% RF)		300		ns
On/off Time	(50% Vctrl to RF)		320		
Input P1dB	50 MHz		26		
	1200 MHz	-	21	-	dBm
IIP3 ²⁾	50 MHz		37		
	1200 MHz	-	37	-	dBm
IIP2 ²⁾	50 MHz		60		
	860 MHz	-	80		dBm
Supply Voltage (Vs)		+3	+5	-	V
Control Voltage	High	Vs-0.5	Vs		
	Low	0	-	+0.5	V
Current			600		uA

1) Attenuation accuracy are calculated at any bit or combination

2) IIP3 and IIP2 are measured with two tones at an input power of +0 dBm/tone separated by 6 MHz.

2.2 Truth Table

State	V1	V2
Insertion loss	Low	Low
7 dB	High	Low
14 dB	Low	High
21 dB	High	High

2.3 Pin Configuration

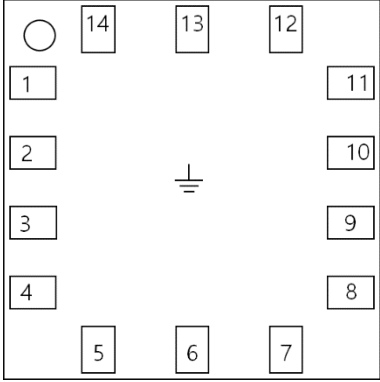
Pin	Description	Simplified Outline
1, 2, 4, 6, 8, 10, 11	No connection	
3	RF1, RF port	
9	RF2, RF port	
5, 7	RF GND	
12	Vs, DC power supply voltage.	
13	V2, DC control voltage. Controls 14 dB attenuation state.	
14	V1, DC control voltage. Controls 7 dB attenuation state.	

Note: Backside metal paddle is DC ground.

2.4 Absolute Maximum Ratings

Parameters	Max. Ratings
Operation Case Temperature	-40 to +85 °C
Storage Temperature	-65 to +150 °C
Device Voltage	+7 V
Input RF Power	+27 dBm @ 50 MHz +22 dBm @ 1200 MHz +15 dBm @ 2700 MHz

2.5 Moisture Sensitivity Level

Level 3 at 260 °C reflow

(Intentionally Blanked)

3. Application: DC ~ 1200 MHz ($V_s = +5\text{ V}$, $75\ \Omega$)

3.1 Application Circuit & Evaluation Board

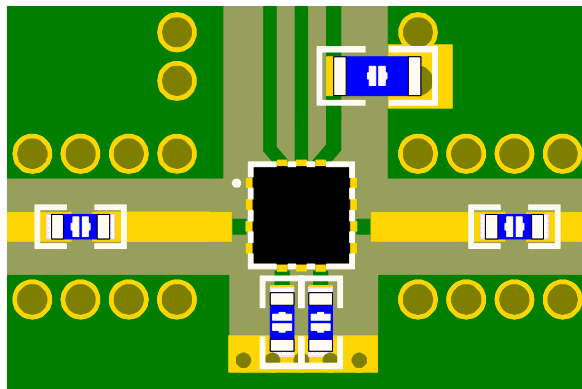
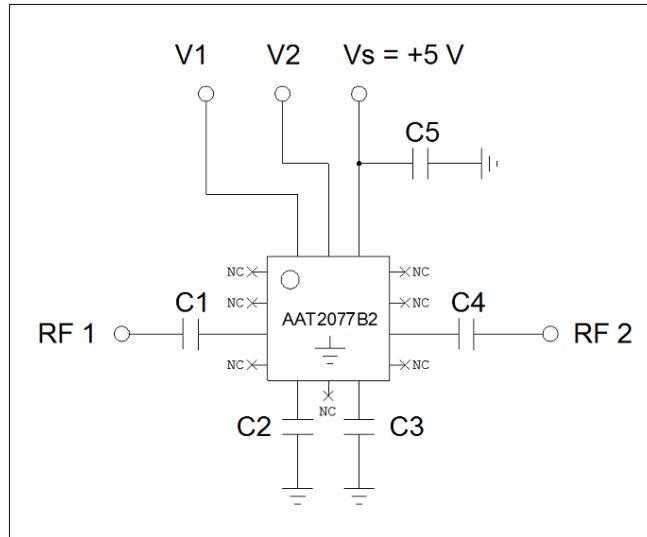

PCB Information	
Material	FR4
Thickness (mm)	0.8
Size (mm)	25x50
EB No.	EB-2x2-QFN14_ATT01

Bill of Material

Symbol	Value	Size	Description	Manufacturer
AAT2077B2	-	-	2-Bit digital attenuator	ASB
C1, C4	1 μF	0402	DC blocking capacitor	Murata
C2, C3	1 μF	0402	Bypass capacitor	Murata
C5	10 μF	0805	Decoupling capacitor	Murata

Note: Bypass capacitors (C2 and C3) should be close to the RF GND(pin 5 and pin 7).

3.2 Plot of Performances

Insertion loss

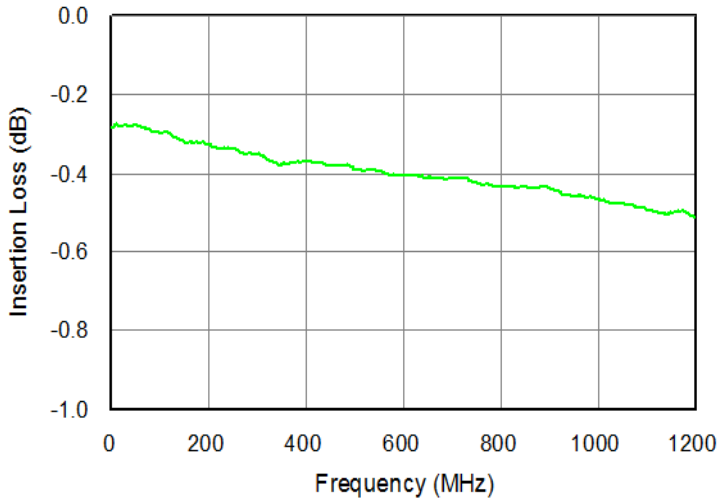

Normalized attenuation all states

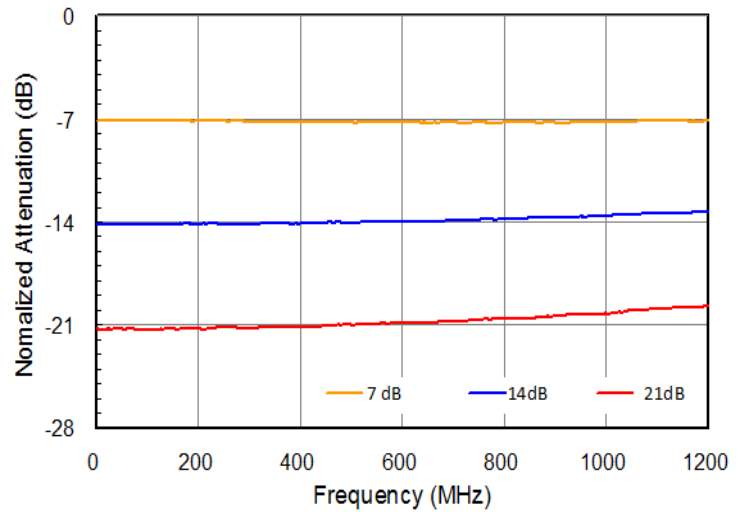

Input return loss over all states

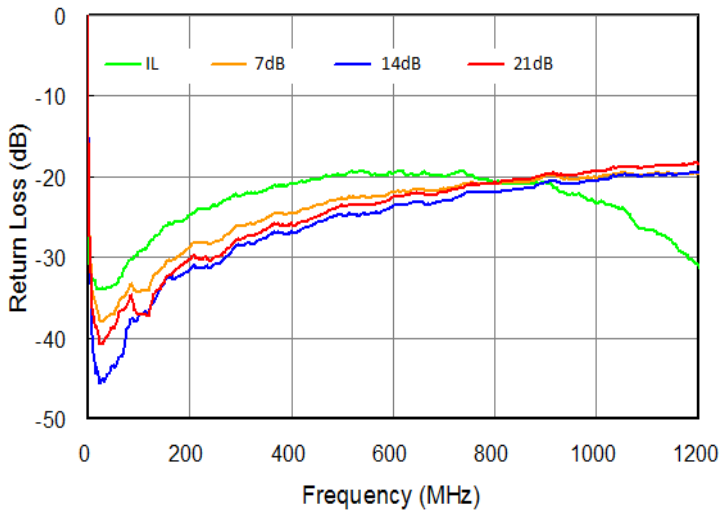

Output return loss over all states

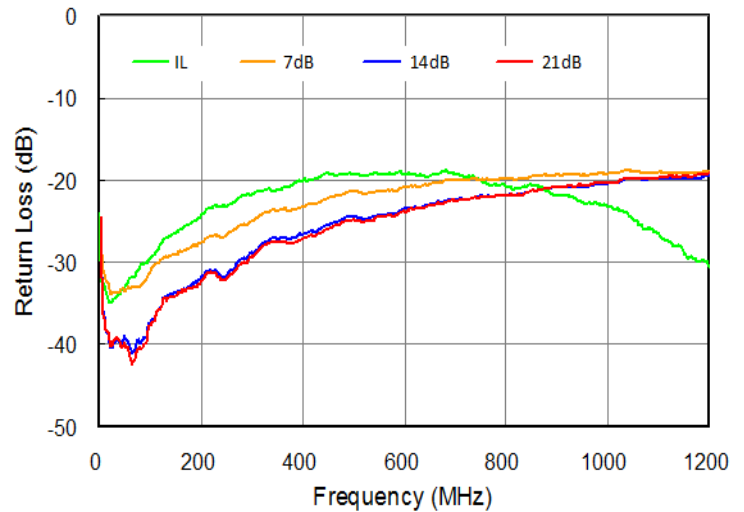

IIP3 vs. Frequency over all states

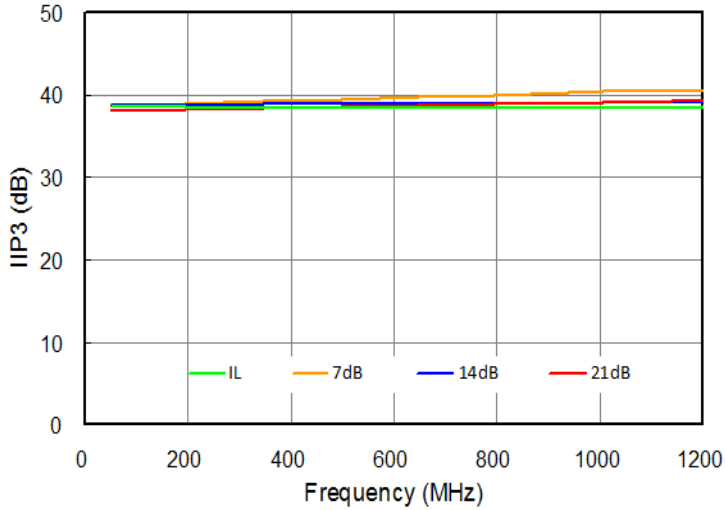

IIP2 vs. Frequency over all states

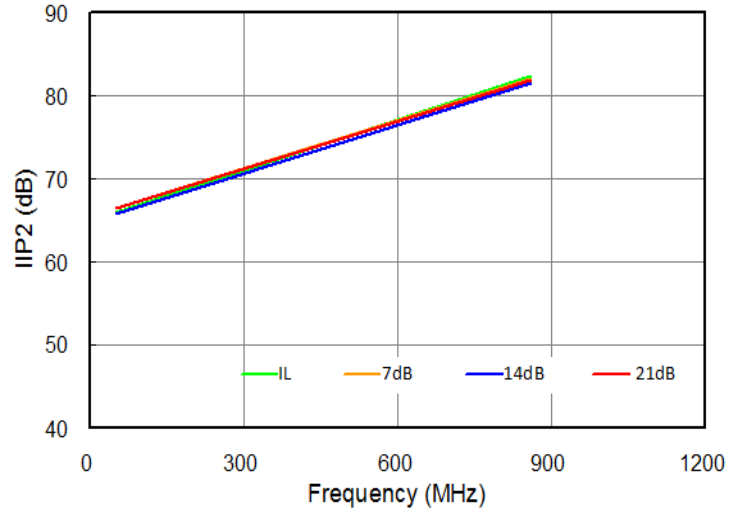

Step error vs. frequency over all states

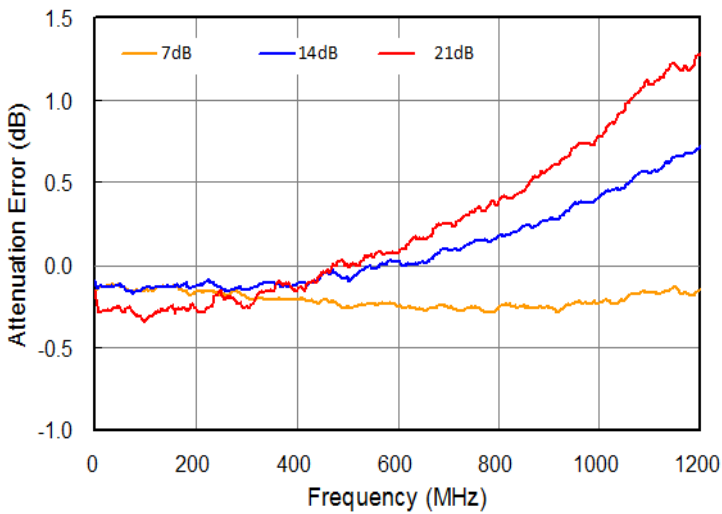

4. Package Outline (UQFN-14L, 2.0x2.0x0.4 mm³)

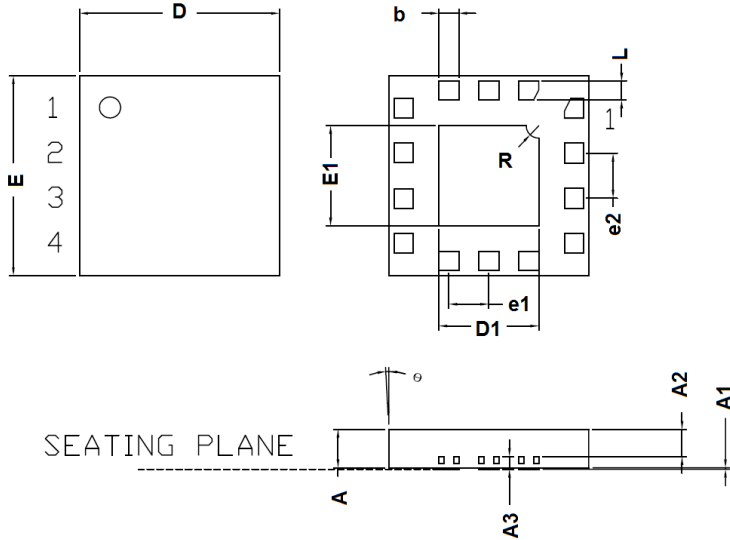

Symbols	Dimensions (In mm)		
	MIN	NOM	MAX
A	0.35	-	0.40
A1	0.00	-	0.05
A2	0.223	-	0.273
A3	-	0.127REF	-
b	0.15	0.20	0.25
D	1.95	2.00	2.03
E	1.95	2.00	2.03
D1	-	1.00BSC	-
E1	-	1.00BSC	-
e1	-	0.40BSC	-
e2	-	0.45BSC	-
L	0.13	0.18	0.23
R	-	0.125BSC	-
theta	-12	-	0
Burr	0.00	0.03	0.06

5. Surface Mount Recommendation (In mm)

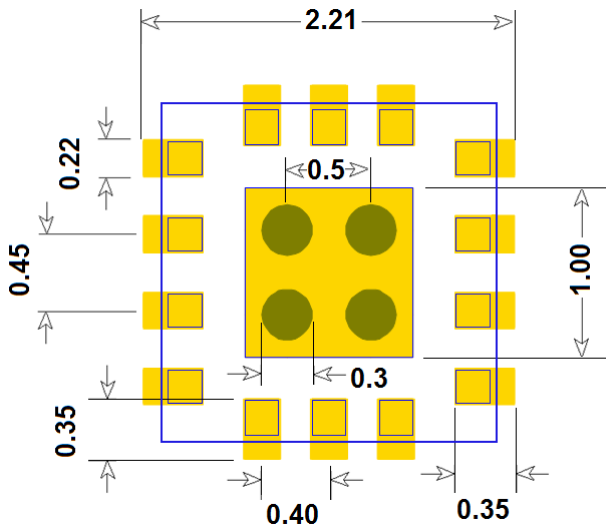

NOTE

1. Recommended is that the ground via holes be placed on the bottom of the exposed pad of the device for better RF and thermal performance, as shown in the drawing at the left side

6. Tape and Reel Information

6.1 UQFN-14L Package

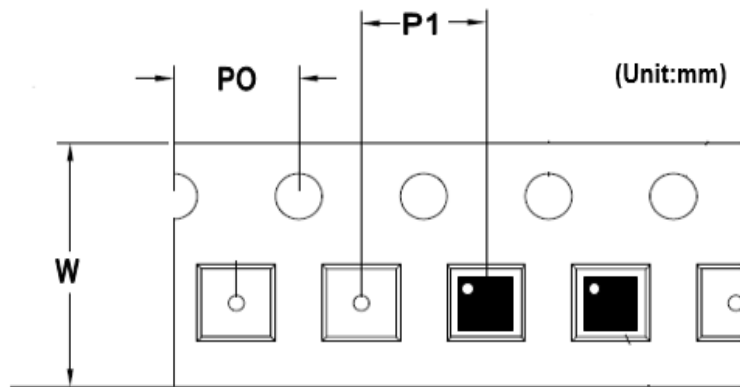

Package	Carrier Width (W)	Pitch (P0)	Pitch (P1)	Part Per Full Reel	Reel Size
UQFN-14L	8 mm	4 mm	4 mm	3,000 pcs	180 mm

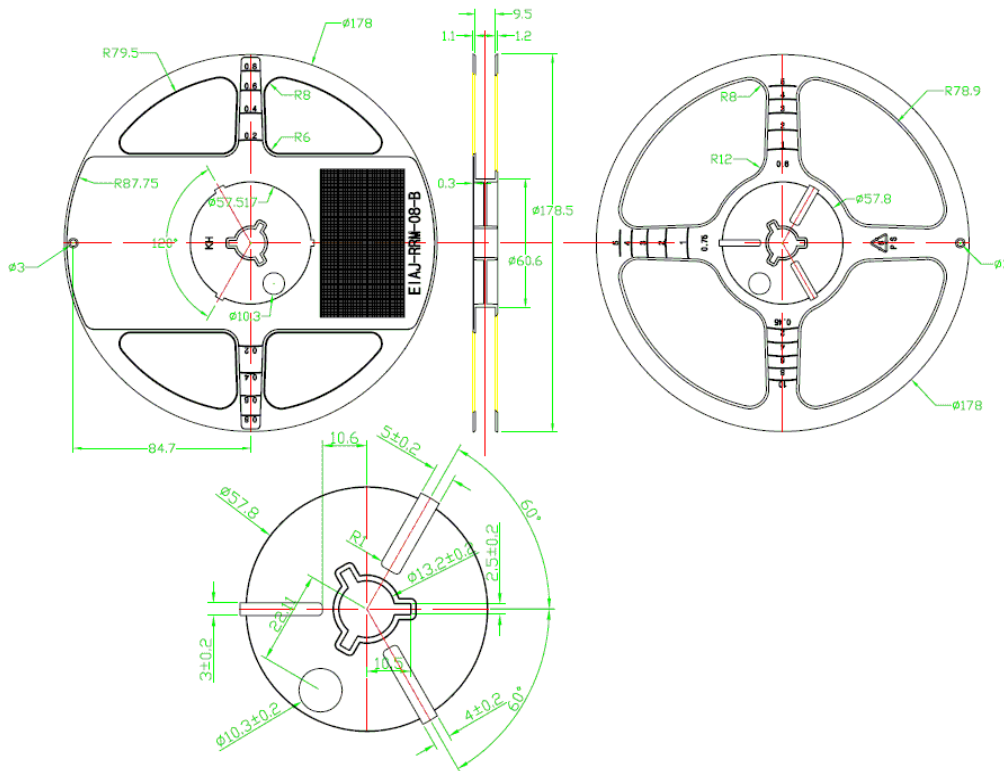

7. Recommended Soldering Reflow Profile

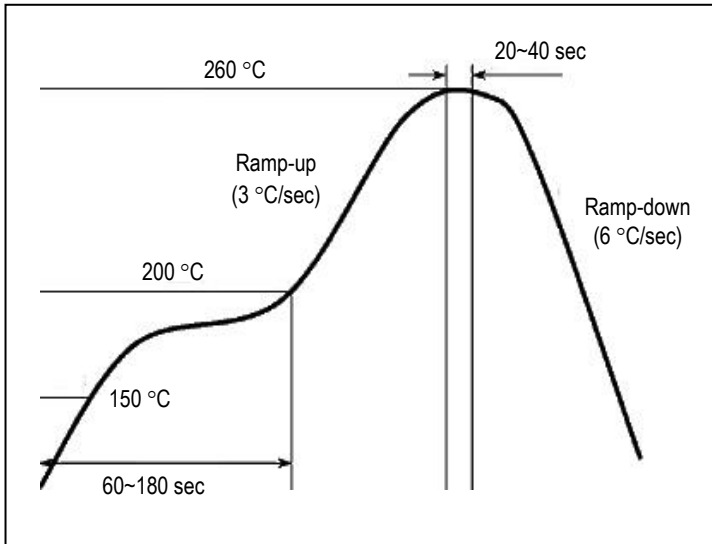

(End of Datasheet)

Copyright ©2017 ASB Inc. All rights reserved. Datasheet subject to change without notice. ASB assumes no responsibility for any errors which may appear in this datasheet. No part of the datasheet may be copied or reproduced in any form or by any means without the prior written consent of ASB.