



# Thin-Film Cascadable Amplifier 5 to 500 MHz

## Technical Data

### UTO/UTC 501 Series

#### Features

- **Frequency Range: 5 to 500 MHz**
- **Medium Gain: 15.5 dB (Typ)**
- **Low Current Drain: 10 mA (Typ)**
- **Temperature Compensated**

#### Applications

- **IF/RF Amplification**
- **Low Power Systems**

#### Description

The 501 Series is a thin-film bipolar RF amplifier that uses resistive feedback and active bias. Input/output blocking capacitors couple the RF through the circuit and inductive tuning provides low VSWR. The 501 Series is available in either the TO-8 hermetic case or connected TC-1A package.

#### Pin Configuration UTO—TO-8U

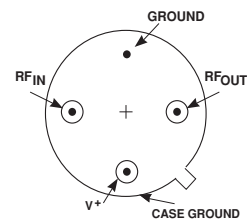

#### UTC—TC-1A

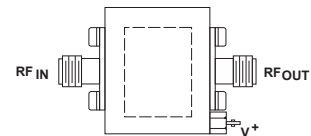

#### Schematic

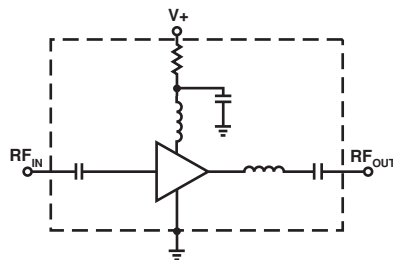

#### Maximum Ratings

Parameter	Maximum
DC Voltage	+17 Volts
Continuous RF Input Power	+13 dBm
Operating Case Temperature	-55 to +125°C
Storage Temperature	-62 to +150°C
"R" Series Burn-In Temperature	+125°C

#### Thermal Characteristics<sup>1</sup>

$\theta_{JC}$	90°C/W
Active Transistor Power Dissipation	67 mW
Junction Temperature Above Case Temperature	6°C
MTBF (MIL-HDBK-217E, $A_{UF}$ @ 90°C)	1,170,000 Hrs.

**Weight:** (typical) UTO—2.1 grams; UTC—21.5 grams

## Electrical Specifications

(Measured in 50  $\Omega$  system @ +15 VDC nominal unless otherwise noted)

Symbol	Characteristic	Typical $T_C = 25^\circ\text{C}$	Guaranteed Specifications		Unit
			$T_C = 0 \text{ to } 50^\circ\text{C}$	$T_C = -55 \text{ to } +85^\circ\text{C}$	
BW	Frequency Range	5-500	5-500	5-500	MHz
GP	Small Signal Gain (Min.)	15.5	14.0	13.5	dB
—	Gain Flatness (Max.)	$\pm 0.5$	$\pm 1.0$	$\pm 1.0$	dB
NF	Noise Figure (Max.)	3.5	4.0	4.5	dB
$P_{1dB}$	Power Output @ +1 dB Comp. (Min.)	+1.0	-2.0	-3.0	dBm
—	Input VSWR (Max.)	<1.5:1	2.0:1	2.0:1	—
—	Output VSWR (Max.)	<1.5:1	2.0:1	2.0:1	—
$IP_3$	Two Tone 3rd Order Intercept Point	+12.0	—	—	dBm
$IP_2$	Two Tone 2nd Order Intercept Point	+13.0	—	—	dBm
$HP_2$	One Tone 2nd Harmonic Intercept Point	+19.0	—	—	dBm
$I_D$	DC Current	10	—	—	mA

## Typical Performance Over Temperature (@ +15 VDC unless otherwise noted)

Key: +25°C —  
+85°C - -  
-55°C —

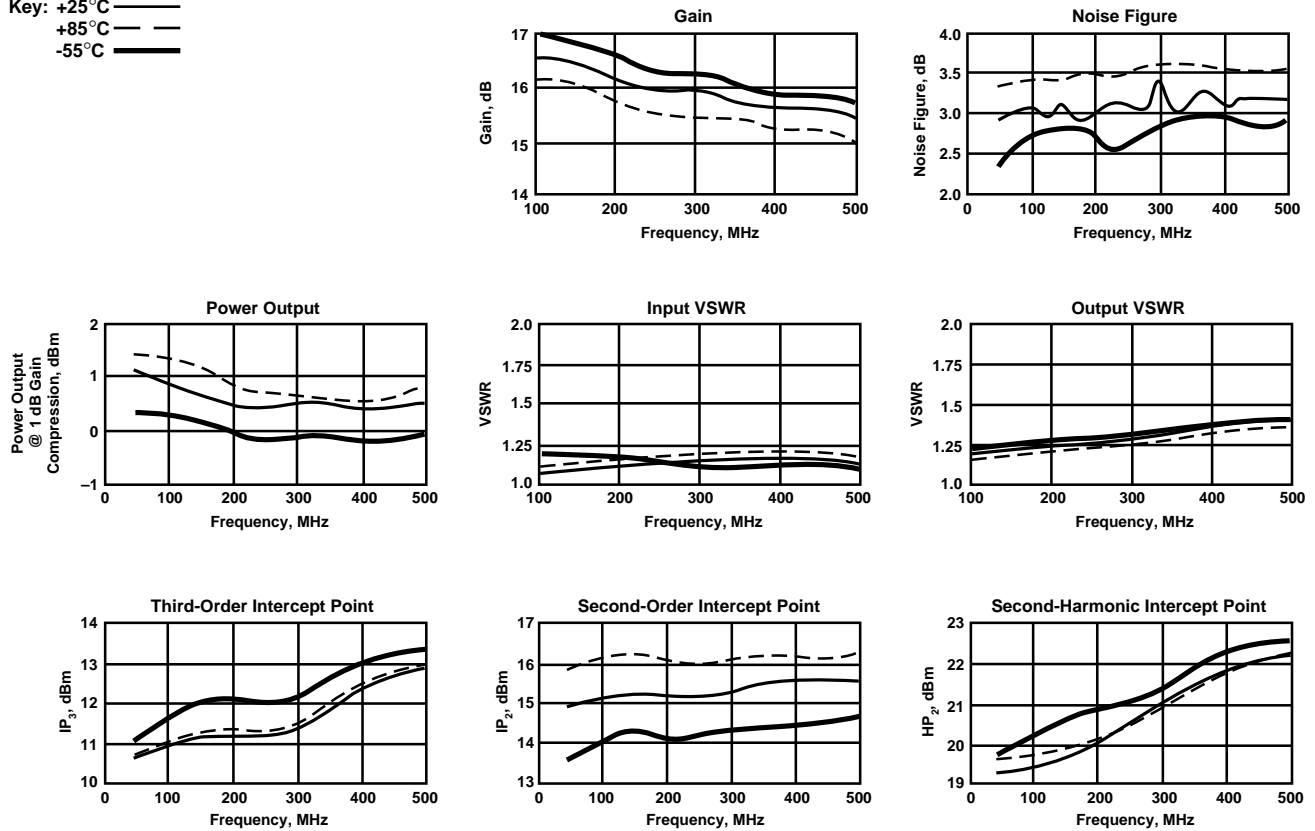

**Automatic Network Analyzer Measurements** (Typical production unit @ +25°C ambient)**Numerical Readings****Bias = 15.00 Volts**

FREQUENCY MHz	VSWR IN	GAIN dB	PHASE DEGREES	PHASE DEV	GROUP DELAY ns	VSWR OUT	ISOLATION dB
100.0	1.07	15.06	158.71	-.69	—	1.06	19.84
150.0	1.14	14.96	149.37	.22	.53	1.10	20.16
200.0	1.17	14.89	139.51	.62	.58	1.10	19.98
250.0	1.19	14.90	128.38	-.24	.58	1.12	20.16
300.0	1.22	14.92	118.62	.25	.55	1.14	20.03
350.0	1.24	14.83	108.62	.51	.59	1.17	19.93
400.0	1.25	14.84	97.36	-.47	.59	1.20	20.14
450.0	1.24	14.97	87.46	-.10	.56	1.22	19.87
500.0	1.22	14.94	77.21	-.09	.57	1.26	19.80
550.0	1.19	14.99	66.82	—	.60	1.31	19.92
600.0	1.12	15.05	55.74	—	.61	1.34	19.54
650.0	1.08	15.00	44.96	—	.64	1.36	19.81
700.0	1.07	15.15	32.62	—	.63	1.35	19.92
750.0	1.15	15.20	22.29	—	.62	1.42	19.61
800.0	1.28	15.13	10.21	—	.70	1.43	19.65
850.0	1.45	15.07	-3.08	—	.72	1.41	19.68
900.0	1.70	14.99	-15.78	—	.73	1.42	20.09
950.0	2.02	14.68	-29.33	—	.76	1.44	19.92
1000.0	2.41	14.49	-43.11	—	.75	1.43	20.42
1050.0	2.91	14.03	-56.17	—	.69	1.46	20.99
1100.0	3.61	13.42	-68.11	—	.70	1.53	21.38
1150.0	4.65	12.97	-81.29	—	.73	1.59	22.47
1200.0	5.63	12.04	-84.41	—	.72	1.66	23.61

LINEARIZATION RANGE: 100.0 to 500.0 MHz

**S-Parameters****Bias = 15.00 Volts**

FREQUENCY MHz	S <sub>11</sub>		S <sub>21</sub>		S <sub>12</sub>		S <sub>22</sub>	
	Mag	Ang	dB	Ang	dB	Ang	Mag	Ang
100.00	.031	74.2	15.06	156.9	-19.83	-5.0	.027	-178.7
200.00	.059	67.8	14.94	138.7	-19.83	-11.9	.038	169.8
300.00	.078	58.2	14.96	118.0	-19.74	-19.3	.060	154.9
400.00	.083	49.8	14.89	96.9	-19.91	-26.2	.083	139.9
500.00	.070	45.5	14.96	77.1	-19.66	-35.0	.113	123.4
600.00	.042	60.7	15.05	55.8	-19.66	-43.4	.137	105.8
700.00	.055	132.8	15.19	33.3	-19.49	-52.3	.163	85.0
800.00	.144	142.6	15.02	11.0	-19.58	-63.4	.176	61.7
900.00	.271	132.2	14.95	-15.2	-19.83	-76.8	.178	31.2
1000.00	.419	117.4	14.49	-40.5	-21.18	-90.4	.164	-8.6

## Product Options

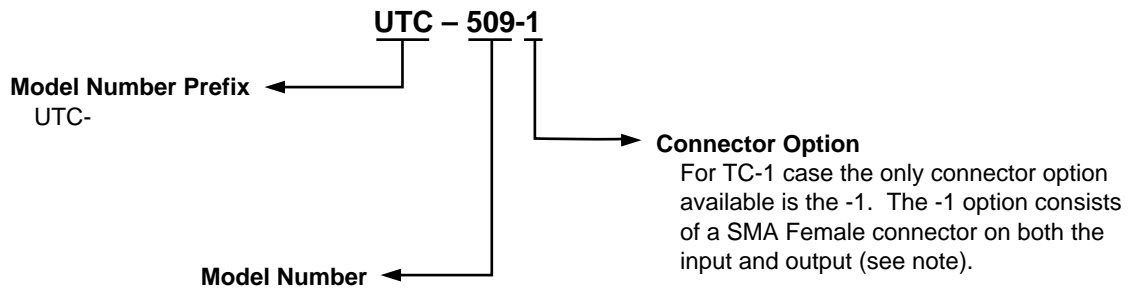
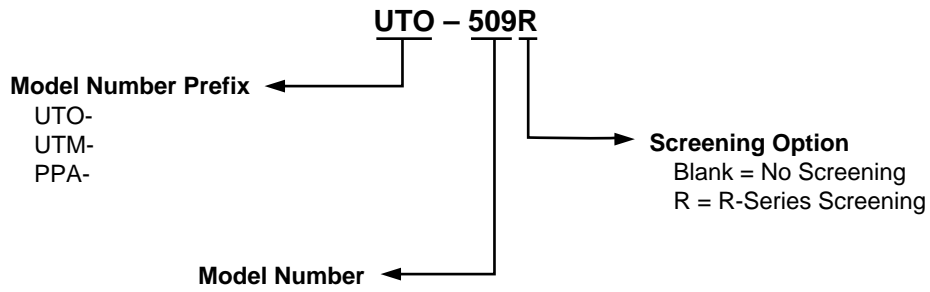

Note: R-Series screening is not available in the TC-1 case as the case is non-hermetic.

**Case Drawings  
TO-8U**

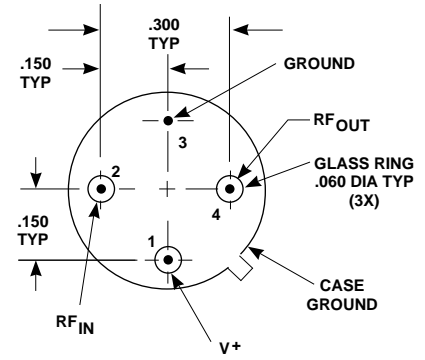
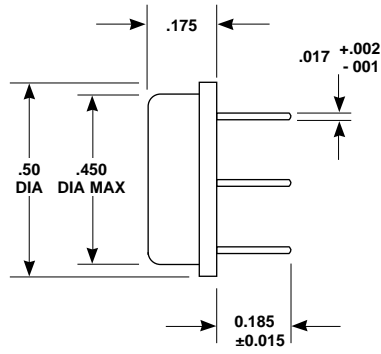
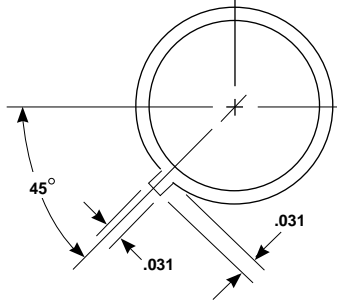

APPROXIMATE WEIGHT 2.1 GRAMS

- NOTES (UNLESS OTHERWISE SPECIFIED):**  
 1. DIMENSIONS ARE SPECIFIED IN INCHES  
 2. TOLERANCES: xx ±.02  
 xxx ±.010

# TC-1A

