

AUIPS6011(S)(R)

INTELLIGENT POWER HIGH SIDE SWITCH

Features

- Over temperature shutdown (with auto-restart)
- Short circuit protection (current limit)
- Reverse battery protection (turns On the MOSFET)
- Full diagnostic capability (short circuit to battery)
- Active clamp
- Open load detection in On and Off state
- Ground loss protection
- Logic ground isolated from power ground
- ESD protection
- Lead Free and RoHS compliant

Description

The AUIPS6011(S)(R) is a five terminal Intelligent Power Switch (IPS) for use in a high side configuration. It features short circuit, over-temperature, ESD protection, inductive load capability and diagnostic feedback. The output current is limited to the Ilim value. The current limitation is activated until the thermal protection acts. The over-temperature protection turns off the device if the junction temperature exceeds the Tshutdown value. It will automatically restart after the junction has cooled 7°C below the Tshutdown value. The reverse battery protection turns On the MOSFET. A diagnostic pin provides different voltage levels for each fault condition. The double level shifter circuitry will allow large offsets between the logic and load ground.

Typical Connection

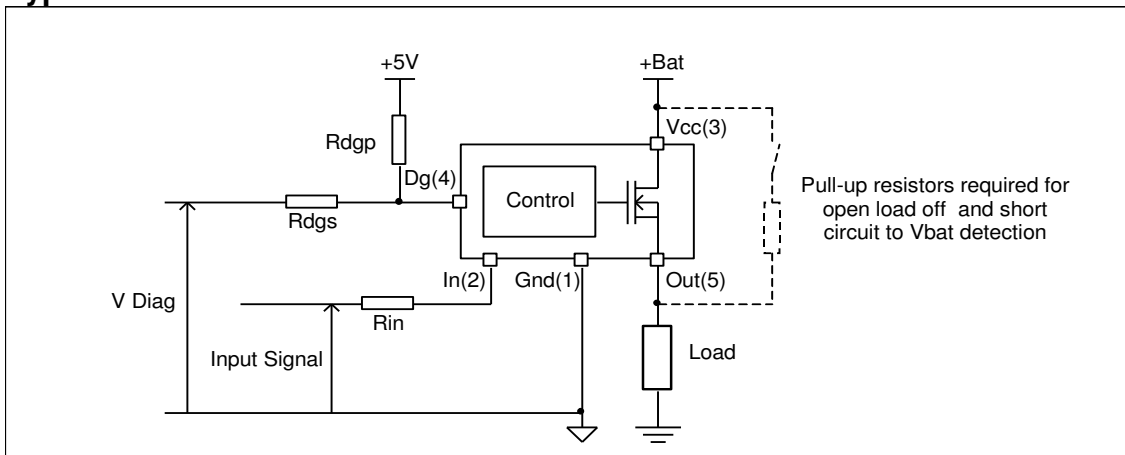

Product Summary

Rds(on)	14mΩ max.
Vclamp	39V
I Limit	60A
Open load	3V / 2.4A

Packages

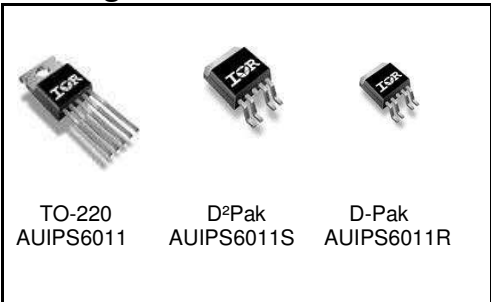

Qualification Information†

Qualification Level		Automotive (per AEC-Q100 ^{††})	
		Comments: This family of ICs has passed an Automotive qualification. IR's Industrial and Consumer qualification level is granted by extension of the higher Automotive level.	
Moisture Sensitivity Level		D2PAK-5L	MSL1, 260°C (per IPC/JEDEC J-STD-020)
		TO-220	Not applicable (non-surface mount package style)
		DPAK-5L	MSL1, 260°C (per IPC/JEDEC J-STD-020)
ESD	Machine Model	Class M2 (+/-150V) ^{†††} (per AEC-Q100-003)	
	Human Body Model	Class H1C (+/-1500V) ^{†††} (per AEC-Q100-002)	
	Charged Device Model (DPAK, D2PAK)	Class C4 (+/-900V) ^{†††} (per AEC-Q100-011)	
	Charged Device Model (TO220)	Class C3B (+/-750V) ^{†††} (per AEC-Q100-011)	
IC Latch-Up Test		Class II, Level A (per AEC-Q100-004)	
RoHS Compliant		Yes	

† Qualification standards can be found at International Rectifier's web site <http://www.irf.com/>

†† Exceptions to AEC-Q100 requirements are noted in the qualification report.

††† Passing voltage level

Absolute Maximum Ratings

Absolute maximum ratings indicate sustained limits beyond which damage to the device may occur. All voltage parameters are referenced to Ground lead. $T_j = -40^{\circ}\text{C}..150^{\circ}\text{C}$, $V_{cc} = 6..35\text{V}$ (unless otherwise specified).

Symbol	Parameter	Min.	Max.	Units	
Vout	Maximum output voltage	$V_{cc}-35$	$V_{cc}+0.3$	V	
Voffset	Maximum logic ground to load ground offset	$V_{cc}-35$	$V_{cc}+0.3$		
Vin	Maximum input voltage	-0.3	5.5		
Vcc max.	Maximum Vcc voltage	—	36		
Vcc cont.	Maximum continuous Vcc voltage	—	28		
Vcc sc.	Maximum Vcc voltage with short circuit protection	—	24		
Iin max.	Maximum IN current	-3	10	mA	
I _{dg} max.	Maximum diagnostic output current	-3	10		
V _{dg}	Maximum diagnostic output voltage	-0.3	5.5	V	
Pd	Maximum power dissipation (internally limited by thermal protection)	R _{th} =5°C/W AUIPS6011	—	25	W
		R _{th} =40°C/W AUIPS6011S 1" sqrt. footprint	—	3.1	
		R _{th} =50°C/W AUIPS6011R 1" sqrt. footprint	—	2.5	
T _j max.	Max. storage & operating temperature junction temperature	-40	150	°C	
T _{soldering}	Soldering temperature (10 seconds)	—	300	°C	

Thermal Characteristics

Symbol	Parameter	Typ.	Max.	Units
R _{th1}	Thermal resistance junction to ambient AUIPS6011 TO220 free air	50	—	°C/W
R _{th2}	Thermal resistance junction to case AUIPS6011 TO220	1.2	—	
R _{th1}	Thermal resistance junction to ambient AUIPS6011S D ² Pak std. footprint	60	—	
R _{th2}	Thermal resistance junction to ambient AUIPS6011S D ² Pak 1" sqrt. Footprint	40	—	
R _{th3}	Thermal resistance junction to case AUIPS6011S D ² Pak	1.2	—	
R _{th1}	Thermal resistance junction to ambient AUIPS6011R D-Pak std. footprint	70	—	
R _{th2}	Thermal resistance junction to ambient AUIPS6011R D-Pak 1" sqrt. Footprint	50	—	
R _{th3}	Thermal resistance junction to case AUIPS6011R D-Pak	1.2	—	

Recommended Operating Conditions

These values are given for a quick design. For operation outside these conditions, please consult the application notes.

Symbol	Parameter	Min.	Max.	Units
V _{IH}	High level input voltage	4	5.5	
V _{IL}	Low level input voltage	0	0.9	
I _{out}	Continuous drain current, T _{ambient} =85°C, T _j =125°C, V _{in} =5V			A
	R _{th} =5°C/W AUIPS6011	—	18	
	R _{th} =40°C/W AUIPS6011S 1" sqrt. footprint	—	6.3	
	R _{th} =50°C/W AUIPS6011R 1" sqrt. footprint	—	5.6	
R _{in}	Recommended resistor in series with IN pin	4	10	kΩ
R _{dgs}	Recommended resistor in series with DG pin for reverse battery protection	4	20	
R _{dg_p}	Recommended pull-up resistor for DG	4	20	
R _{ol}	Recommended pull-up resistor for open load detection	5	100	
F max.	Max. switching frequency	—	0.3	kHz

Static Electrical Characteristics

T_j=-40°C..150°C, V_{cc}=6..28V (unless otherwise specified), typical values are given for V_{cc}=14V and T_j=25°C

Symbol	Parameter	Min.	Typ.	Max.	Units	Test Conditions
R _{ds(on)}	ON state resistance T _j =25°C	—	11	14	mΩ	V _{in} =5V, I _{out} =20A
	ON state resistance T _j =150°C	—	19.5	25		V _{in} =5V, I _{out} =20A
	ON state resistance T _j =25°C, V _{cc} =6V	—	12	17		V _{in} =5V, I _{out} =20A
	ON state resistance during reverse battery T _j =25°C	—	15	20		V _{cc} -Gnd=-14V
V _{cc op.}	Operating voltage range with short circuit protection	6	—	24	V	
V clamp 1	V _{cc} to Out clamp voltage 1	36.5	39	43		I _{out} =50mA
V clamp 2	V _{cc} to Out clamp voltage 2	—	40	—		I _{out} =16A (see Fig. 1)
I _{cc Off}	Supply current when Off and V _{out} connected to ground with R<4Ω	—	4	9	μA	V _{in} =0V, V _{out} =0V, T _j =25°C, V _{cc} =14V
I _{cc On}	Supply current when On	—	2.2	5	mA	V _{in} =5V, V _{cc} =14V
V _{ih}	Input high threshold voltage	—	2.5	3	V	
V _{il}	Input low threshold voltage	1.5	2	—		
I _{n hyst.}	Input hysteresis	0.2	0.5	1		
I _{in On}	Input current when device is On	—	40	100	μA	V _{in} =5V
I _{dg}	Dg leakage current	—	0.1	10		V _{dg} =5V
V _{dg}	Low level DG voltage	—	0.25	0.4		V

Switching Electrical Characteristics

V_{cc}=14V, Resistive load=6Ω, V_{in}=5V, T_j=-40°C..150°C, typical values are given for T_j=25°C

Symbol	Parameter	Min.	Typ.	Max.	Units	Test Conditions
T _{don}	Turn-on delay time	—	30	80	μs	see Fig. 3
Tr1	Rise time to V _{out} =V _{cc} -5V	—	25	80		
Tr2	Rise time to V _{out} =0.9 x V _{cc}	—	80	300		
	T _j =-40°C..25°C					
	T _j =25°C..150°C		40	100		
dV/dt (On)	Turn On dV/dt	—	0.3	—	V/μs	
E _{On}	Turn On energy	—	4	—	mJ	
T _{doff}	Turn-off delay time	—	70	150	μs	
T _f	Fall time to V _{out} =0.1 x V _{cc}	—	30	80		
dV/dt (Off)	Turn Off dV/dt	—	0.7	—	V/μs	
E _{Off}	Turn Off energy	—	1.5	—	mJ	

Protection Characteristics

$T_j = -40^{\circ}\text{C}..150^{\circ}\text{C}$, $V_{cc} = 6..28\text{V}$ (unless otherwise specified), typical values are given for $V_{cc} = 14\text{V}$ and $T_j = 25^{\circ}\text{C}$

Symbol	Parameter	Min.	Typ.	Max.	Units	Test Conditions
Ilim	Internal current limit	35	60	85	A	$V_{out} = 0\text{V}$, $T_j = 25^{\circ}\text{C}$
Tsd+	Over temperature high threshold	150(1)	165	—	°C	See fig. 2
Tsd-	Over temperature low threshold	—	158	—		
Vsc	Short-circuit detection voltage(2)	2	3	4	V	
UV+	Under voltage protection Vcc going up	—	5	6.2		
UV -	Under voltage protection Vcc going down	—	4.5	5.8		
VOL Off	Open load detection threshold	2	3	4		
I OL On	Open load detection threshold	0.5	2	3	A	$T_j = -40..25^{\circ}\text{C}$
		0.5	1.6	2.4		$T_j = 25..150^{\circ}\text{C}$

(1) Guaranteed by design

(2) Reference to Vcc

True Table

Operating Conditions	IN	OUT	DG
Normal	H	H	H
Normal	L	L	H
Open Load	H	H	L
Open Load (3)	L	H	L
Short circuit to Gnd	H	L	L
Short circuit to Gnd	L	L	H
Short circuit to Vcc	H	H	L (4)
Short circuit to Vcc (5)	L	H	L
Over-temperature	H	L	L
Over-temperature	L	L	H

(3) With a pull-up resistor connected between the output and Vcc.

(4) Vds lower than 10mV.

(5) Without a pull-up resistor connected between the output and Vcc.

Lead Assignments

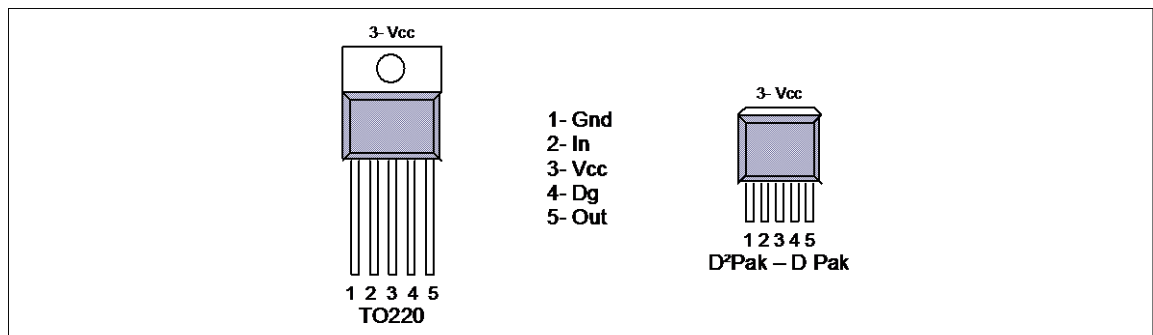

Functional Block Diagram

All values are typical

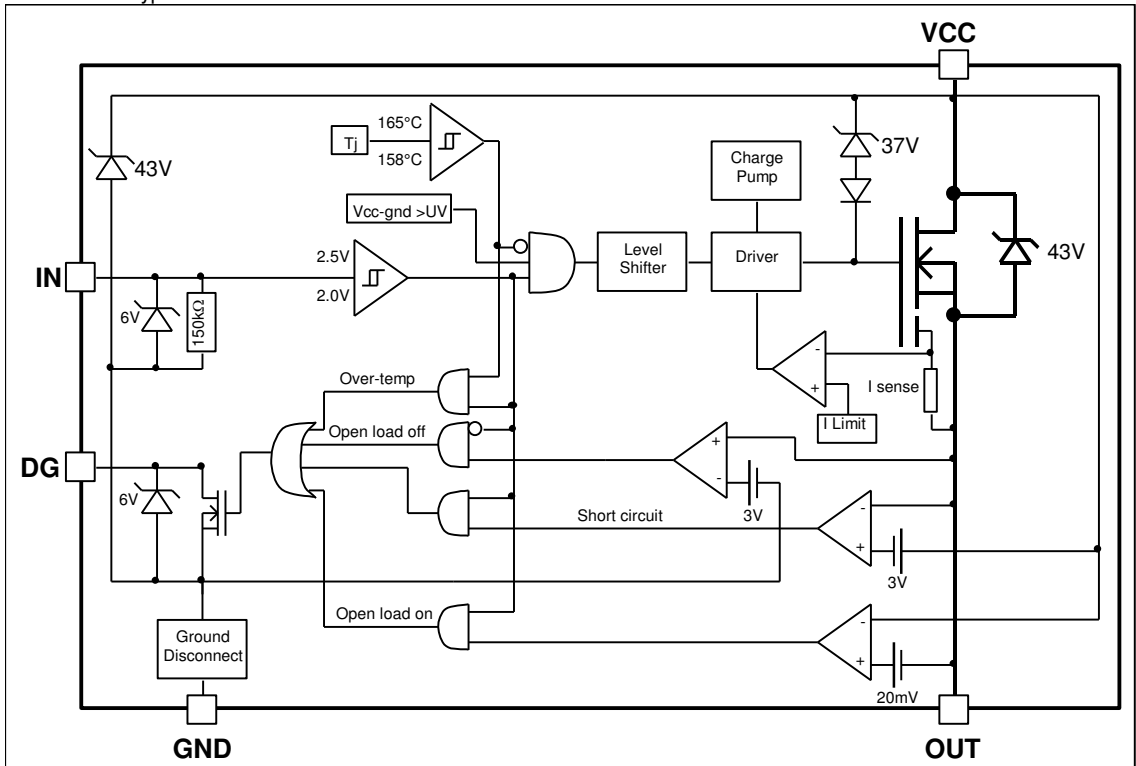

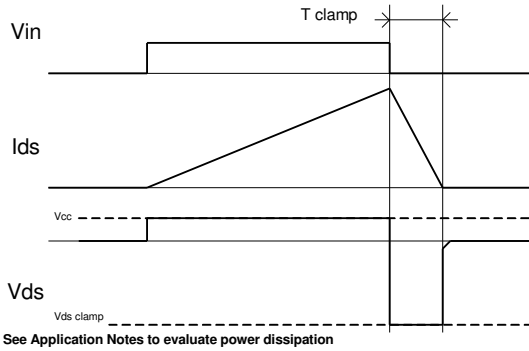

Figure 1 – Active clamp waveforms

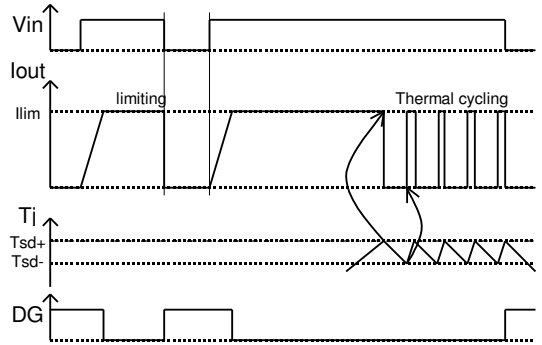

Figure 2 – Protection timing diagram

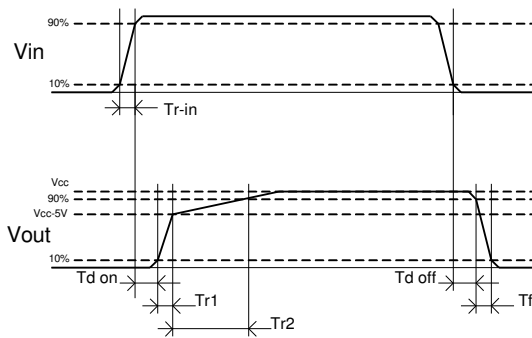

Figure 3 – Switching times definitions

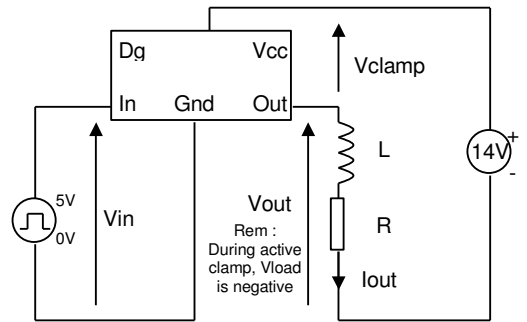

Figure 4 – Active clamp test circuit

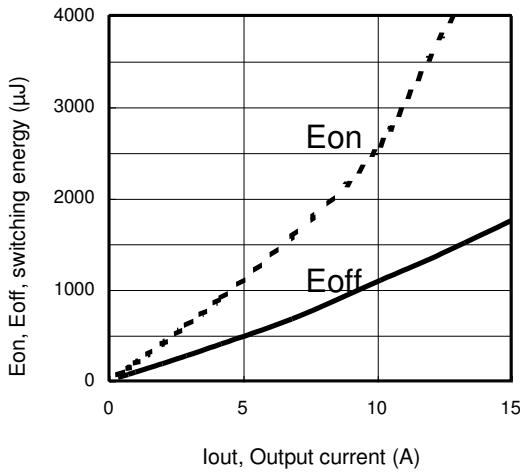

Figure 5 – Switching energy (μJ) Vs Output current (A)

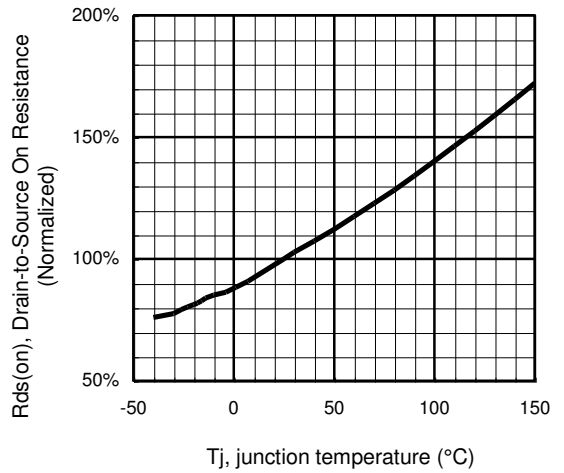

Figure 6 - Normalized $R_{ds(on)}$ (%) Vs T_j ($^{\circ}\text{C}$)

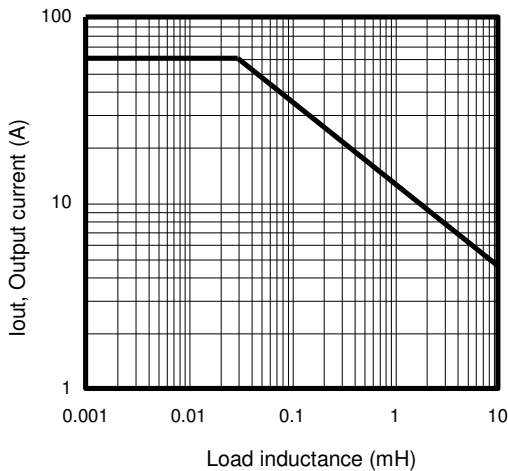

Figure 7 – Max. Output current (A) Vs Load inductance (mH)

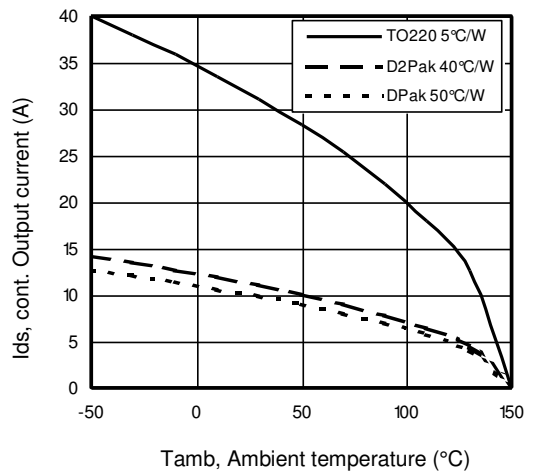

Figure 8 – Max. output current (A) Vs Ambient temperature ($^{\circ}\text{C}$)

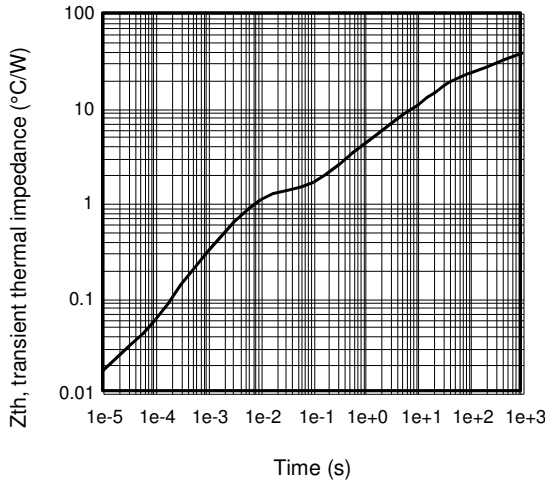

Figure 9 – Transient thermal impedance (°C/W) Vs time (s)

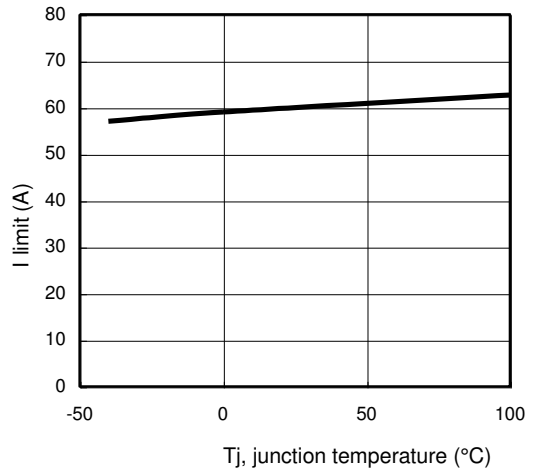

Figure 10 – I limit (A) Vs junction temperature (°C)

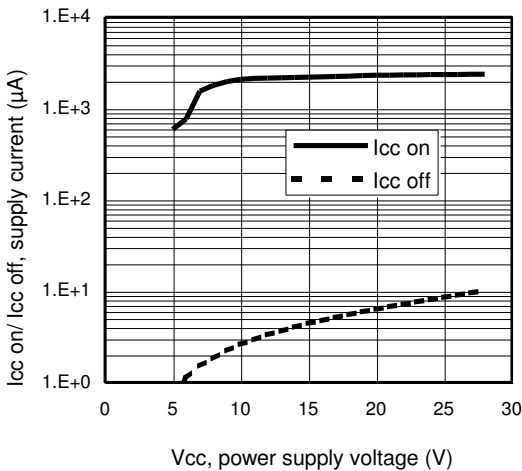

Figure 11 – Icc on/ Icc off (µA) Vs Vcc (V)*

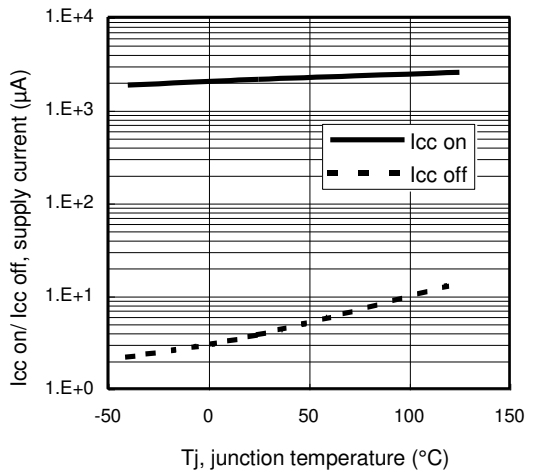
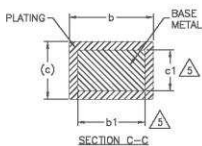
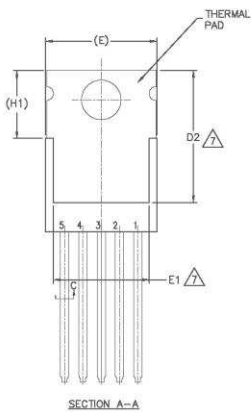
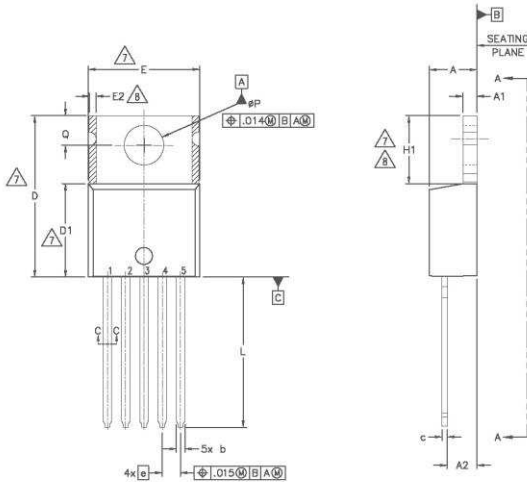

Figure 12 – Icc on/ Icc off (µA) Vs Tj (°C)*

*Vout connected to ground with R<4Ω

Case Outline - TO220 (5 leads)



SYMBOL	DIMENSIONS				NOTES
	MILLIMETERS		INCHES		
	MIN.	MAX.	MIN.	MAX.	
A	3.56	4.83	.140	.190	5
A1	0.51	1.40	.020	.055	
A2	2.03	2.92	.080	.115	5
b	0.64	0.89	.025	.035	
b1	0.64	0.84	.025	.033	5
c	0.36	0.51	.014	.024	
c1	0.36	0.56	.014	.022	4
D	14.22	16.51	.560	.650	7
D1	8.38	9.02	.330	.355	
D2	11.68	12.88	.460	.507	7
E	9.65	10.67	.380	.420	
E1	6.86	8.89	.270	.350	7
E2	-	0.76	-	.030	8
e	1.70 BSC		.067 BSC		7,8
H1	5.84	6.86	.230	.270	
L	12.70	14.73	.500	.580	
ØP	3.53	3.73	.139	.147	
Q	2.54	3.05	.100	.120	

NOTES:

- 1.- DIMENSIONING AND TOLERANCING AS PER ASME Y14.5 M-1994.
- 2.- DIMENSIONS ARE SHOWN IN INCHES [MILLIMETERS].
- 3.- LEAD DIMENSION AND FINISH UNCONTROLLED IN L1.
- 4.- DIMENSION D, D1 & E DO NOT INCLUDE MOLD FLASH. MOLD FLASH SHALL NOT EXCEED .005" (0.127) PER SIDE. THESE DIMENSIONS ARE MEASURED AT THE OUTERMOST EXTREMES OF THE PLASTIC BODY.
- 5.- DIMENSION b1 & c1 APPLY TO BASE METAL ONLY.
- 6.- CONTROLLING DIMENSION - INCHES.
- 7.- THERMAL PAD CONTOUR OPTIONAL WITHIN DIMENSIONS E,H1,D2 & E1
- 8.- DIMENSION E2 X H1 DEFINE A ZONE WHERE STAMPING AND SINGULARITY IRREGULARITIES ARE ALLOWED.
- 9.- OUTLINE CONFORMS TO JEDEC TO-220, EXCEPT A2 (max.) AND D2 (min.) WHERE DIMENSIONS ARE DERIVED FROM THE ACTUAL PACKAGE OUTLINE.
- 10.- LEADS AND DRAIN ARE PLATED WITH 100X Sn

Case Outline D2PAK - 5 Leads

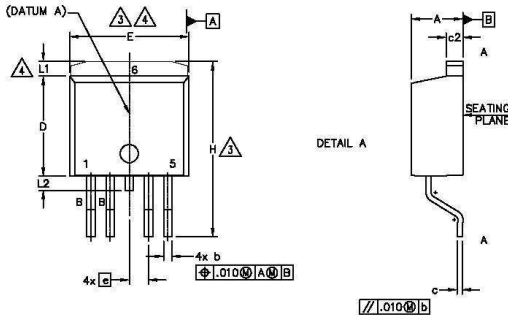
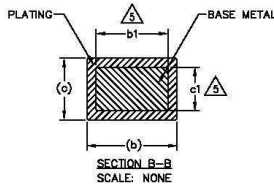
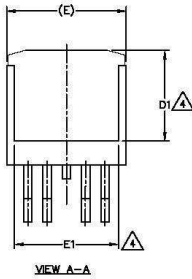
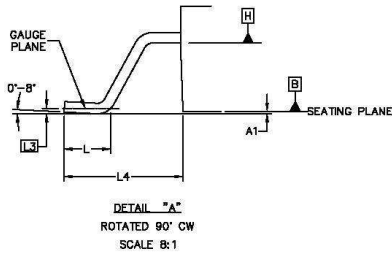

NOTES:

1. DIMENSIONING AND TOLERANCING AS PER ASME Y14.5M-1994
2. DIMENSIONS ARE SHOWN IN MILLIMETERS [INCHES].
3. DIMENSION D & E DO NOT INCLUDE MOLD FLASH. MOLD FLASH SHALL NOT EXCEED 0.127 [.005"] PER SIDE. THESE DIMENSIONS ARE MEASURED AT THE OUTMOST EXTREMES OF THE PLASTIC BODY AT DATUM H.
4. THERMAL PAD CONTOUR OPTIONAL WITHIN DIMENSION E, L1, D1 & E1.
5. DIMENSION b1 AND c1 APPLY TO BASE METAL ONLY.
6. DATUM A & B TO BE DETERMINED AT DATUM PLANE H.
7. CONTROLLING DIMENSION: INCH.
8. OUTLINE CONFORMS TO JEDEC OUTLINE TD-263BA.
9. LEADS AND DRAIN ARE PLATED : 100% Sn

SYMBOL	DIMENSIONS				NOTES
	MILLIMETERS		INCHES		
	MIN.	MAX.	MIN.	MAX.	
A	4.06	4.83	.160	.190	4
A1	-	0.254	-	.010	
b	0.51	0.99	.020	.039	4
b1	0.51	0.89	.020	.035	
c	0.38	0.74	.015	.029	4
c1	0.38	0.58	.015	.023	
c2	1.14	1.65	.045	.065	3
D	8.38	9.65	.330	.380	
D1	6.86	-	.270	-	3
E	9.65	10.67	.380	.420	
E1	6.22	-	.245	-	3
e	1.70 BSC	-	.067 BSC	-	
H	14.61	15.88	.575	.625	3
L	1.78	2.79	.070	.110	
L1	-	1.68	-	.066	3
L2	-	1.78	-	.070	
L3	0.25 BSC	-	.010 BSC	-	3
L4	4.78	5.28	.188	.208	

Tape & Reel D2PAK - 5 Leads

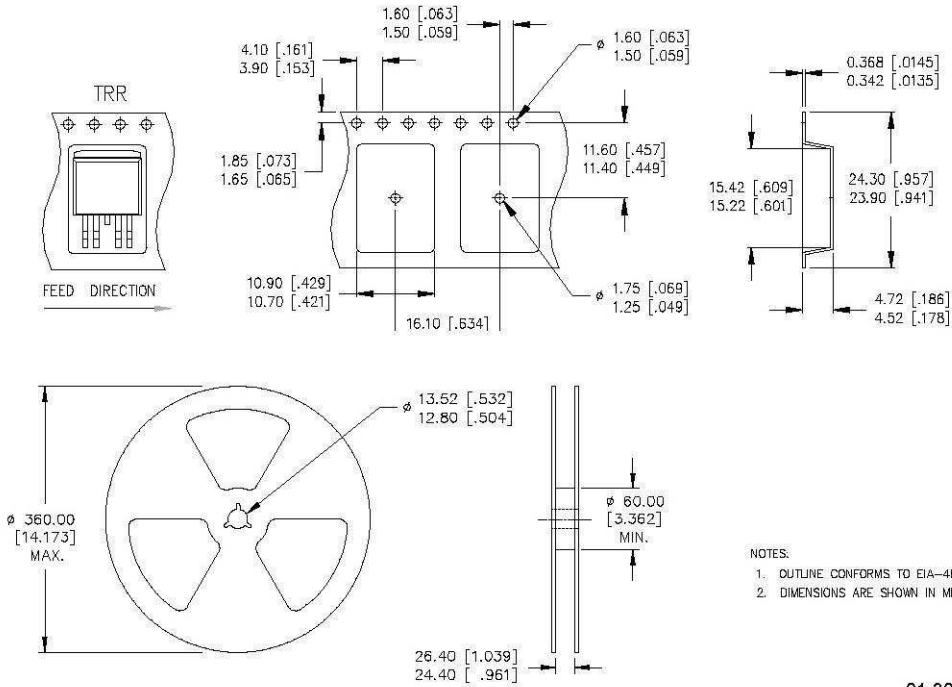

- NOTES:
1. OUTLINE CONFORMS TO EIA-481 & EIA-541.
 2. DIMENSIONS ARE SHOWN IN MILLIMETERS [INCHES].

01-3071 00 / 01-3072 00

Case Outline DPAK - 5 Leads

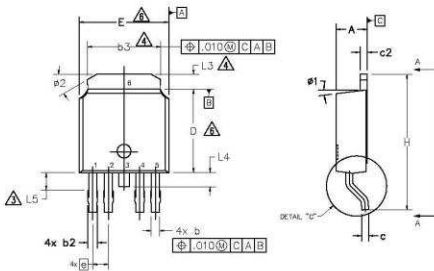
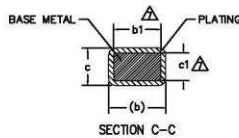
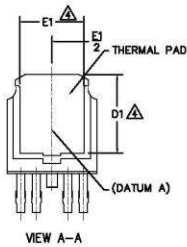
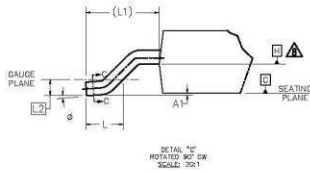

SYMBOL	DIMENSIONS				NOTES
	MILLIMETERS		INCHES		
	MIN.	MAX.	MIN.	MAX.	
A	2.18	2.39	.086	.094	2
A1	—	0.13	—	.005	
b	0.56	0.79	.022	.031	2
b1	.056	0.74	.022	.029	
b2	0.65	0.89	.026	.035	2
b3	4.95	5.46	.195	.215	
c	0.46	0.61	.018	.024	3
c1	0.41	0.56	.016	.022	
c2	0.46	0.89	.018	.035	3
D	5.97	6.22	.235	.245	
D1	5.21	—	.205	—	3
E	6.35	6.73	.250	.265	
E1	4.32	—	.170	—	3
e	1.14 BSC	—	.045 BSC	—	
H	9.40	10.41	.370	.410	3
L	1.40	1.78	.055	.070	
L1	2.74 BSC	—	.108 REF.	—	3
L2	0.51 BSC	—	.020 BSC	—	
L3	0.89	1.27	.035	.050	3
L4	—	1.02	—	.040	
L5	1.14	1.52	.045	.060	3
ø	0"	10"	0"	10"	
ø1	0"	15"	0"	15"	3
ø2	28"	32"	28"	32"	

NOTES:

- 1.- DIMENSIONING AND TOLERANCING AS PER ASME Y14.5M-1994
- 2.- DIMENSIONS ARE SHOWN IN INCHES [MILLIMETERS]
- 3.- LEAD DIMENSION UNCONTROLLED IN L5.
- 4.- DIMENSION D1, E1, L3 & b3 ESTABLISH A MINIMUM MOUNTING SURFACE FOR THERMAL PAD.
- 5.- SECTION C-C DIMENSIONS APPLY TO THE FLAT SECTION OF THE LEAD BETWEEN .005 AND 0.10 [0.13 AND 0.25] FROM THE LEAD TIP.
- 6.- DIMENSION D & E DO NOT INCLUDE MOLD FLASH. MOLD FLASH SHALL NOT EXCEED .005 [0.13] PER SIDE. THESE DIMENSIONS ARE MEASURED AT THE OUTMOST EXTREMES OF THE PLASTIC BODY.
- 7.- DIMENSION b1 & c1 APPLIED TO BASE METAL ONLY.
- 8.- DATUM A & B TO BE DETERMINED AT DATUM PLANE H.
- 9.- OUTLINE CONFORMS TO JEDEC OUTLINE TO-252.
10. LEADS AND DRAIN ARE PLATED WITH 100% Sn

Tape & Reel DPAK - 5 Leads

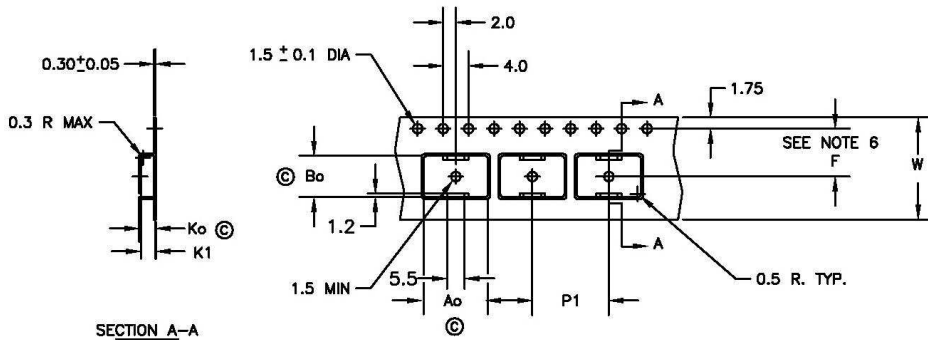

SECTION A-A

$A_o = 10.5 \text{ mm}$
 $B_o = 7.0 \text{ mm}$
 $K_o = 2.8 \text{ mm}$
 $K_1 = 2.4 \text{ mm}$
 $F = 7.5 \text{ mm}$
 $P_1 = 12.0 \text{ mm}$
 $W = 16.0 \pm .3 \text{ mm}$

NOTES:

1. 10 SPROCKET HOLE PUNCH CUMULATIVE TOLERANCE ± 0.02
2. CAMBER NOT TO EXCEED 1mm IN 100mm
3. MATERIAL: CONDUCTIVE BLACK POLYSTYRENE
4. A_o AND B_o MEASURED ON A PLANE 0.3mm ABOVE THE BOTTOM OF THE POCKET
5. K_o MEASURED FROM A PLANE ON THE INSIDE BOTTOM OF THE POCKET TO THE TOP SURFACE OF THE CARRIER
6. POCKET POSITION RELATIVE TO THE SPROCKET HOLE MEASURED AS TRUE POSITION OF POCKET, NOT POCKET HOLE
7. VENDOR: (OPTIONAL)
8. MUST ALSO MEET REQUIREMENTS OF EIA STANDARD #EIA-481A, TAPING OF SURFACE-MOUNT COMPONENTS FOR AUTOMATIC PLACEMENT.
9. TOLERANCE TO BE MANUFACTURER STANDARD
10. SURFACE RESISTIVITY OF MOLDED MATL: MUST MEASURE LESS THAN OR EQUAL TO 10^8 OHMS PER SQUARE. MEASURED IN ACCORDANCE TO PROCEDURE GIVEN IN ASTM D-257 & ASTM D-991 (REF. C-9000 SPEC.)
11. TOTAL LENGTH PER REEL MUST BE 79 METERS
12. © CRITICAL DIMENSION

Part Marking Information

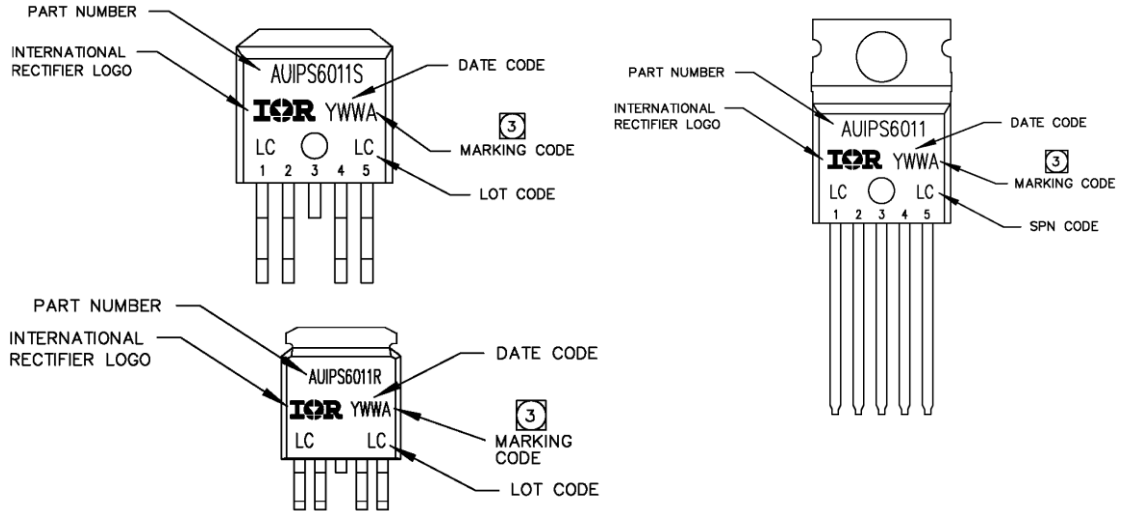

Ordering Information

Base Part Number	Package Type	Standard Pack		Complete Part Number
		Form	Quantity	
AUIPS6011	TO220-5-Leads	Tube	50	AUIPS6011
AUIPS6011S	D2-Pak-5-Leads	Tube	50	AUIPS6011S
		Tape and reel left	800	AUIPS6011STRL
		Tape and reel right	800	AUIPS6011STRR
AUIPS6011R	D-Pak-5-Leads	Tube	75	AUIPS6011R
		Tape and reel	2000	AUIPS6011RTR
		Tape and reel left	3000	AUIPS6011RTRL
		Tape and reel right	3000	AUIPS6011RTRR

IMPORTANT NOTICE

Unless specifically designated for the automotive market, International Rectifier Corporation and its subsidiaries (IR) reserve the right to make corrections, modifications, enhancements, improvements, and other changes to its products and services at any time and to discontinue any product or services without notice. Part numbers designated with the "AU" prefix follow automotive industry and / or customer specific requirements with regards to product discontinuance and process change notification. All products are sold subject to IR's terms and conditions of sale supplied at the time of order acknowledgment.

IR warrants performance of its hardware products to the specifications applicable at the time of sale in accordance with IR's standard warranty. Testing and other quality control techniques are used to the extent IR deems necessary to support this warranty. Except where mandated by government requirements, testing of all parameters of each product is not necessarily performed.

IR assumes no liability for applications assistance or customer product design. Customers are responsible for their products and applications using IR components. To minimize the risks with customer products and applications, customers should provide adequate design and operating safeguards.

Reproduction of IR information in IR data books or data sheets is permissible only if reproduction is without alteration and is accompanied by all associated warranties, conditions, limitations, and notices. Reproduction of this information with alterations is an unfair and deceptive business practice. IR is not responsible or liable for such altered documentation. Information of third parties may be subject to additional restrictions.

Resale of IR products or serviced with statements different from or beyond the parameters stated by IR for that product or service voids all express and any implied warranties for the associated IR product or service and is an unfair and deceptive business practice. IR is not responsible or liable for any such statements.

IR products are not designed, intended, or authorized for use as components in systems intended for surgical implant into the body, or in other applications intended to support or sustain life, or in any other application in which the failure of the IR product could create a situation where personal injury or death may occur. Should Buyer purchase or use IR products for any such unintended or unauthorized application, Buyer shall indemnify and hold International Rectifier and its officers, employees, subsidiaries, affiliates, and distributors harmless against all claims, costs, damages, and expenses, and reasonable attorney fees arising out of, directly or indirectly, any claim of personal injury or death associated with such unintended or unauthorized use, even if such claim alleges that IR was negligent regarding the design or manufacture of the product.

IR products are neither designed nor intended for use in military/aerospace applications or environments unless the IR products are specifically designated by IR as military-grade or "enhanced plastic." Only products designated by IR as military-grade meet military specifications. Buyers acknowledge and agree that any such use of IR products which IR has not designated as military-grade is solely at the Buyer's risk, and that they are solely responsible for compliance with all legal and regulatory requirements in connection with such use.

IR products are neither designed nor intended for use in automotive applications or environments unless the specific IR products are designated by IR as compliant with ISO/TS 16949 requirements and bear a part number including the designation "AU". Buyers acknowledge and agree that, if they use any non-designated products in automotive applications, IR will not be responsible for any failure to meet such requirements.

For technical support, please contact IR's Technical Assistance Center
<http://www.irf.com/technical-info/>

WORLD HEADQUARTERS:

101 N Sepulveda Blvd., El Segundo, California 90245
Tel: (310) 252-7105

Revision History

Revision	Date	Notes/Changes
E	September, 12th 2011	AU release
F	May 15, 2012	Add the test condition for the ICC (off) parameters