

Off-Line LED Driver ICs

Features and Benefits

- Buck topology
- High input voltage: up to 250 V or 450 V, depending on product
- Constant current control circuit:
 - Fixed off-time PWM constant current control, off-time adjustable by external components
 - Externally adjustable output current by input voltage to REF pin
- External PWM signal:
 - Dimming controlled by PWM signal to PWM pin
 - Turning off LEDs by low input voltage to PWM pin
- Protection features:
 - Undervoltage lockout protection (UVLO)
 - Overcurrent protection (OCP) with latched shutdown
 - Thermal shutdown protection (TSD) with auto restart

Description

The LC5200 series is a power IC, for non-isolated LED driver with commercial power supply applications, which includes both a main controller integrated circuit (MIC) and a power MOSFET. Its high voltage capability allows direct connection to a wide range of supply voltages ranging from 25 to 400 V (recommended). The LC5200 uses constant current mode to drive LEDs. The LC5200D series package is a fully molded DIP8 with pin 7 removed for greater isolation, and the LC5200S series package is an SOP8.

Applications

- LED lighting fixtures
- LED light bulbs

Packages

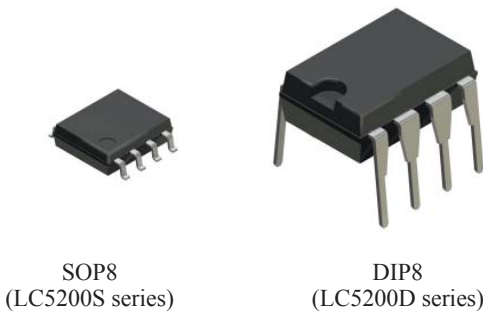

SOP8
(LC5200S series)

DIP8
(LC5200D series)

Not to scale

The product lineup for the LC5200 series provides the following options:

Part Number	Input Voltage, V_{BB}		Output Current, I_o (A)	$R_{DS(ON)}(max)$ (Ω)	Package	
	Absolute Maximum (V)	Recommended Operating Range* (V)				
LC5202D	250	25 to 200	0.5	2.2	DIP8	
LC5202S					SOP8	
LC5205D	450	25 to 400		1.0	6	DIP8
LC5205S						SOP8
LC5203D	250	25 to 200	1.3		DIP8	
LC5210D					450	25 to 400

*Minimum input voltage of recommended range depends on LED output voltage.

Electrical Characteristics

- The polarity value for current specifies a sink as "+," and a source as "–," referencing the IC.
- When pin numbers of the SOP8 differ from those of the DIP8, they are indicated in parentheses for the SOP8.

Absolute Maximum Ratings Unless specifically noted, T_A is 25°C

Characteristic	Symbol	Notes	Pins	Rating	Unit
Main Power Supply Voltage	V _{BB}	LC5202D LC5202S LC5203D	6 – 8 (7 – 8)	250	V
		LC5205D LC5205S LC5210D		450	V
Output Breakdown Voltage	V _O	LC5202D LC5202S LC5203D	5 – 4 (5,6 – 4)	250	V
		LC5205D LC5205S LC5210D		450	V
Output Current ¹	I _O	LC5202D LC5202S LC5205D LC5205S	5 – 4 (5,6 – 4)	0.5	A
		LC5203D LC5210D			1.0
PWM Pin Voltage ²	V _{PWM}		2 – 8	–0.3 to V _Z	V
REF Pin Input Voltage	V _{REF}		3 – 8	–0.3 to V _{REG} + 0.3	V
SEN Pin Voltage	V _{SEN}	Pulse width ≥ 1 μs	4 – 8	–0.3 to 4	V
Allowable Power Dissipation ^{3,4}	P _D	LC5202S LC5205S	–	0.85	W
		LC5202D LC5203D LC5205D LC5210D	–	1.73	W
Operating Ambient Temperature	T _A		–	–40 to 105	°C
Storage Temperature	T _{stg}		–	–40 to 150	°C
Channel Temperature	T _J		–	150	°C

¹The Output Current rating may be limited by duty cycle, ambient temperature, and heat sinking. Under any set of conditions, do not exceed the specified junction temperature, T_J.

²V_Z here is the breakdown voltage of the Zener diode that is internally connected between the PWM pin and GND: V_Z = 6.3 V (typ). Maximum input current is 1 mA.

³Allowable Power Dissipation, P_D, depends on PWB circuit trace layout.

⁴Refer to the T_A versus P_D curve.

T_A versus P_D Curve

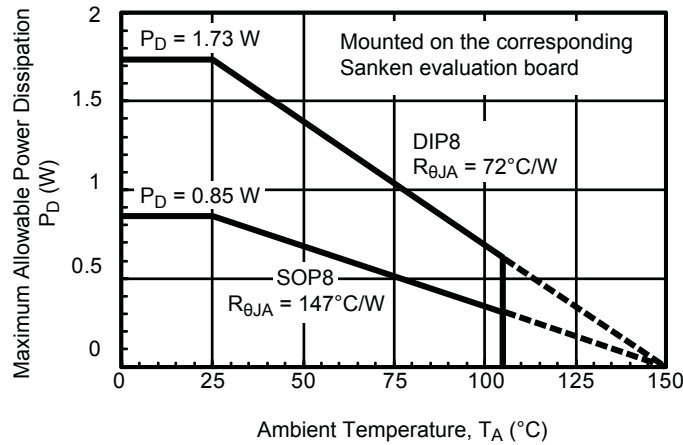

Recommended Operating Conditions*

Characteristic	Symbol	Notes	Pins	Min.	Max.	Unit
Main Power Supply Voltage	V _{BB}	LC5202D LC5202S LC5203D	6 – 8 (7 – 8)	25	200	V
		LC5205D LC5205S LC5210D		25	400	V
Average Output Current	I _{O(AVG)}	LC5202D LC5202S LC5205D LC5205S	5 – 4 (5,6 – 4)	–	0.4	A
		LC5203D LC5210D		–	0.8	A
REF Pin Input Voltage	V _{REF}	Normal operation	3 – 8	–	0.8	V
Case Temperature	T _C	Center of branded side, T _J ≤ 150°C	–	–	105	°C

*Recommended operating conditions means operating conditions that maintain normal device functions as shown in the Electrical Characteristics table.

Electrical Characteristics Unless specifically noted, T_A is 25°C, $V_{BB} = 140$ V

Characteristic	Symbol	Test Conditions		Pins	Min.	Typ.	Max.	Unit
Power Supply Current	I_{BBS}	Output off		6 – 8 (7 – 8)	—	0.8	1.2	mA
	I_{BB}	Normal operation		6 – 8 (7 – 8)	—	2	—	mA
Output MOSFET Breakdown Voltage	$V_{(BR)DSS}$	LC5202D LC5202S LC5203D	$I_D = 1$ mA	5 – 4 (5,6 – 4)	250	—	—	V
		LC5205D LC5205S LC5210D			450	—	—	V
Output MOSFET On-Resistance	$R_{DS(ON)}$	LC5202D LC5202S	$I_D = 0.5$ A	5 – 4 (5,6 – 4)	—	1.2	2.2	Ω
		LC5203D	$I_D = 1.0$ A		—	0.7	1.3	Ω
		LC5205D LC5205S	$I_D = 0.5$ A		—	3.5	6	Ω
		LC5210D	$I_D = 1.0$ A		—	1.7	3	Ω
Body Diode Forward Voltage	V_F	LC5202D LC5202S	$I_F = 0.5$ A	4 – 5 (4 – 5,6)	—	0.8	1.0	V
		LC5203D	$I_F = 1.0$ A		—	0.75	1.2	V
		LC5205D LC5205S	$I_F = 0.5$ A		—	0.8	0.9	V
		LC5210D	$I_F = 1.0$ A		—	0.88	1.0	V
UVLO Threshold (Turn on)	$V_{UVLO(ON)}$	VBB pin		6 – 8 (7 – 8)	—	14	—	V
UVLO Threshold (Turn off)	$V_{UVLO(OFF)}$	VBB pin		6 – 8 (7 – 8)	—	13	—	V
REG Pin Output Voltage	V_{REG}	$I_{REG} = -0.1$ mA		1 – 8	11.5	12	12.5	V
REG Pin Output Current	I_{REG}	$V_{REG} = 11$ V		1 – 8	—	—	-2	mA
REF Pin Input Voltage	V_{REF}			3 – 8	0	—	1	V
REF Pin Input Current	I_{REF}			3 – 8	-10	—	10	μ A
Current Control Detection Voltage	V_{SEN}			4 – 8	$V_{REF} - 0.03$	V_{REF}	$V_{REF} + 0.03$	V
OCP Detection Voltage	V_{OCP}			4 – 8	—	3	—	V
SEN Pin Current	I_{SEN}			4 – 8	-10	—	10	μ A
PWM Blanking Time	t_{BLK}			—	—	400	—	ns
PWM Operation Frequency	f_{PWM}	Duty cycle = 50%		2 – 8	—	—	200	kHz
Output MOSFET Rise Time	t_r	$I_O = 0.4$ A		5 – 4 (5,6 – 4)	—	20	—	ns
Output MOSFET Fall Time	t_f	$I_O = 0.4$ A		5 – 4 (5,6 – 4)	—	50	—	ns
Thermal Shutdown Threshold	T_{TSD}	Temperature of Control Part		—	—	150	—	°C
Thermal Shutdown Hysteresis	$T_{TSD(HYS)}$	Temperature of Control Part		—	—	55	—	°C
Thermal Resistance	$R_{\theta JA}$	LC52xxD	Mounted on the Sanken evaluation board; the thermal resistance between MOSFET and ambient temperature	—	—	—	72	°C/W
		LC52xxS		—	—	—	147	°C/W

Pin-out Diagrams

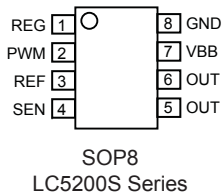
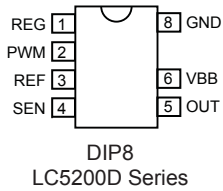

Pin List Table

Name	Number		Function
	LC52xxD (DIP8)	LC52xxS (SOP8)	
REG	1	1	Internal regulator supply, provides current to internal and external circuits; connect a 0.1 μ F bypass capacitor between this pin and GND
PWM	2	2	Input for PWM control; to use internal PWM, connect a CR (capacitor and resistor) for setting off-time; to use external PWM, connect to PWM signal source
REF	3	3	Reference voltage input; sets peak output current of OUT pin (internal power MOSFET) for internal PWM control by REF pin voltage
SEN	4	4	Output current detection; detects peak output current for internal PWM control, and detects overcurrent for OCP; connect to current detection resistor, R_S
OUT	5	5, 6	Drain of internal power MOSFET
VBB	6	7	Supply voltage; provides power to internal circuits through internal regulator
-	7		LC5200D DIP8 pin removed to increase creepage distance between high voltage pin and low voltage pin (Note: apply user's criteria for creepage distance when using LC5200S SOP8)
GND	8	8	Ground pin

Functional Block Diagram

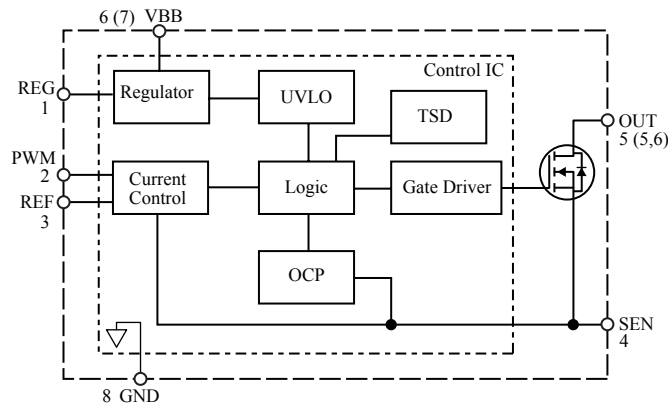

When pin numbers of the SOP8 differ from those of the DIP8, they are indicated in parentheses for the SOP8

Internal Circuit Descriptions

This section describes the functions displayed in the Functional Block diagram.

Regulator

This regulator steps-down from the supply voltage, V_{BB} , to 12 V, and provides power to internal circuits and external devices. A ceramic capacitor of 0.1 μ F should be connected close to the REG pin to stabilize operation because some pulse currents flow through the gate capacitor when charging the internal power MOSFET.

Current Control

The output current is controlled constant in internal PWM mode, by comparing the REF pin voltage with the SEN pin voltage.

Undervoltage Lockout (UVLO)

This continually monitors whether the output voltage from the Regulator function is normal, and prevents abnormal operation resulting from low input voltage. When the VBB pin voltage is lower than the UVLO threshold (Turn-off), $V_{UVLO(OFF)}$, the IC reverts to the state before startup. In addition, this function is available during power-on reset, for releasing latched shutdowns resulting from operation of protection functions.

Thermal Shutdown (TSD)

This continually monitors the chip temperature of the Control Part. When the temperature increases to T_{TSD} or higher, the output of the OUT pin turns off to prevent damage from abnormally high temperature. After TSD operation, when the temperature decreases to T_{TSD} minus $T_{TSD(HYS)}$ or lower, or after cycling power to the IC (that is, the VBB pin voltage falling down to $V_{UVLO(OFF)}$ and then rising to $V_{UVLO(ON)}$), the IC returns to normal operation.

Because this circuit is in the Control Part, there is a delay before temperature increases in the internal power MOSFET are conducted to the Control Part. If the temperature of the power MOSFET increases rapidly, the power MOSFET may be damaged before TSD is activated. Therefore, it is necessary design the application well to protect against this.

Overcurrent Protection (OCP)

The drain current is detected by the current detection resistor, R_S . When the SEN pin voltage, V_{SEN} , reaches the OCP detection voltage, V_{OCP} , or more, the OCP function is activated, and thus the output of the OUT pin turns off, in latch mode. To release latch mode, cycling power to the IC (that is, the VBB pin voltage falling down to $V_{UVLO(OFF)}$ and then rising to $V_{UVLO(ON)}$) is required.

Note: The OCP function is activated only when the SEN pin voltage, V_{SEN} , reaches V_{OCP} by excessive output current flowing to R_S . Therefore if the output current is restricted to less than its target value, for example by current limitations of the inductor, even though the LEDs are shorted, OCP would not be activated.

Logic

This controls the enabling and disabling of the output of the OUT pin according to signals from the current control circuit and/or the various protection circuits. The output is enabled only when the operation is normal and the current control circuit outputs the on-signal for the OUT pin.

Gate Driver Operation

Gate driver for internal power MOSFET.

Internal Power MOSFET

An internal power MOSFET for LED driving is incorporated in the IC series, according to the individual product ratings for current and voltage.

Typical Application Circuit

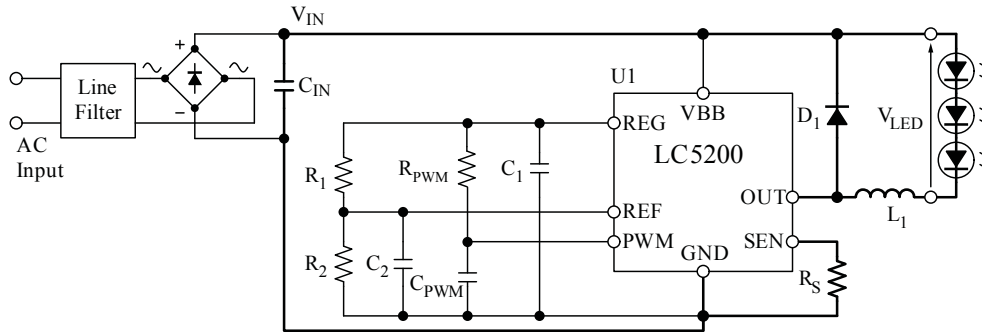
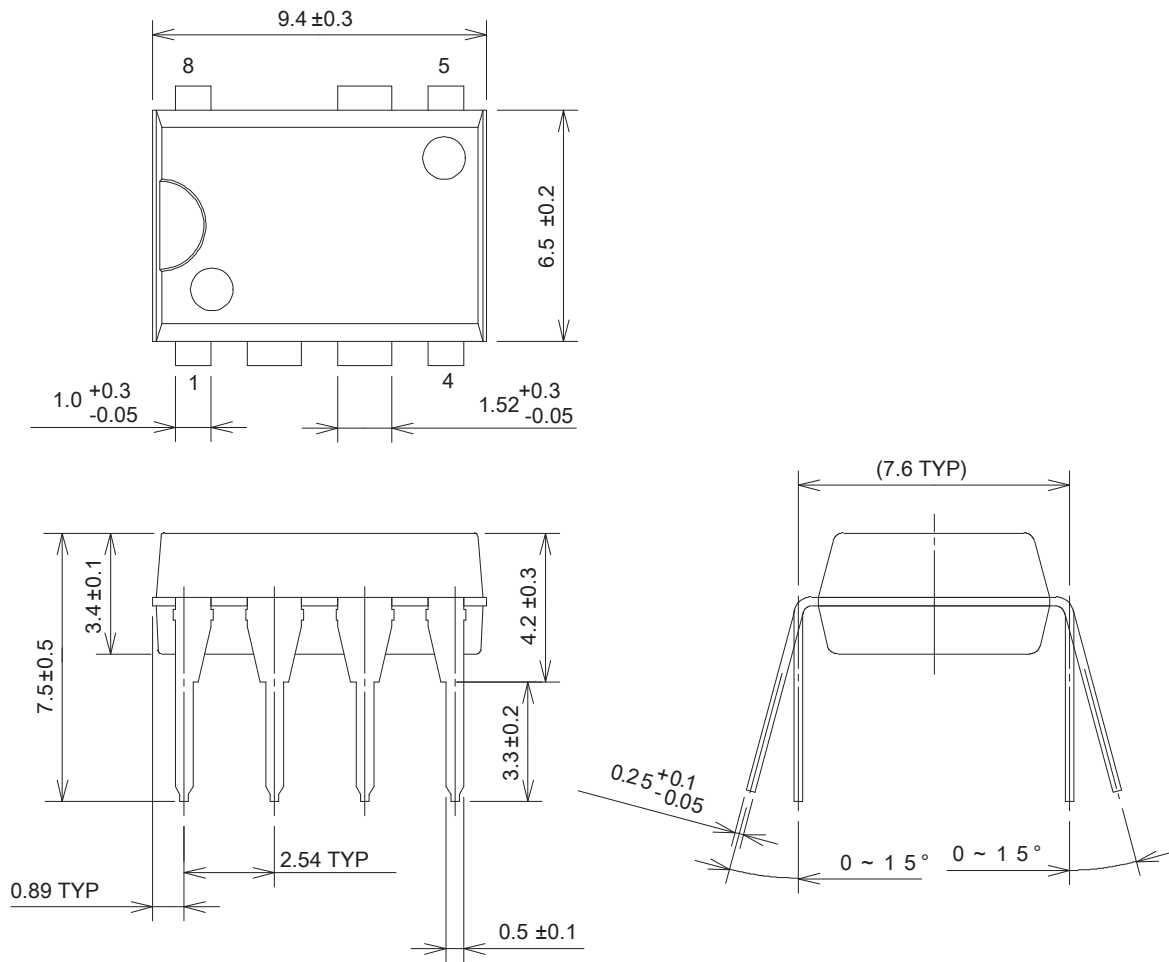

Figure 1. Typical application circuit example for a buck configuration; for component values, see Application Information section

Package Diagrams

DIP8



Unit: mm



Pb-free. Device composition compliant with the RoHS directive.

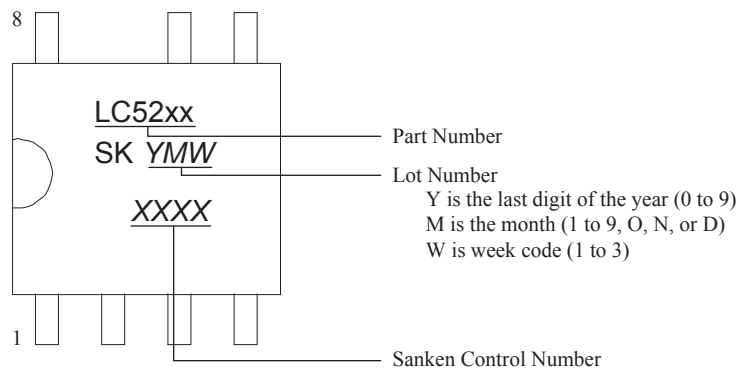

SOP8

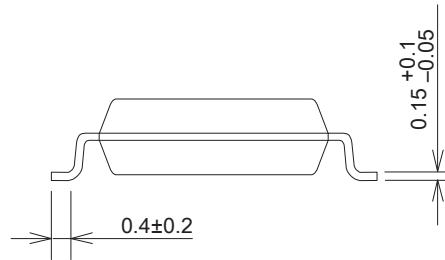
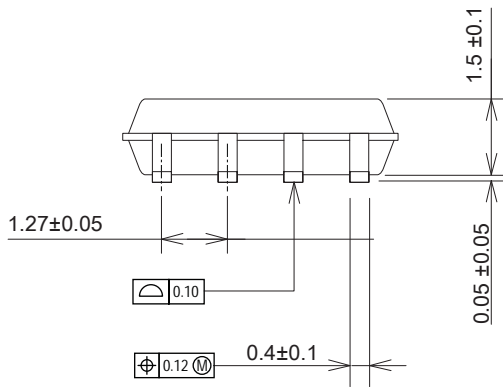
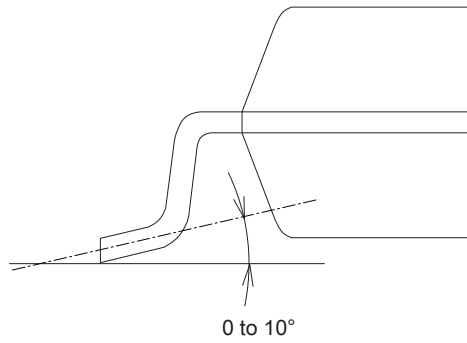
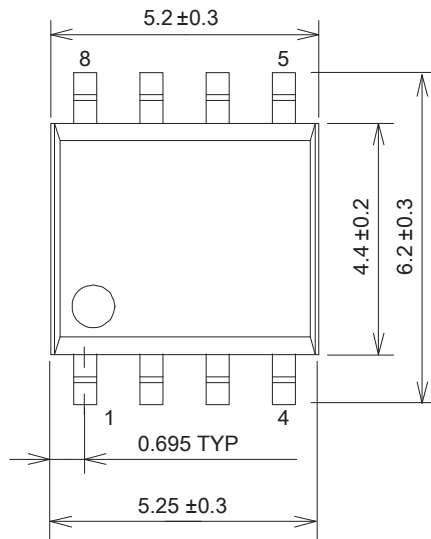

Unit: mm



Pb-free.
Device composition compliant
with the RoHS directive.

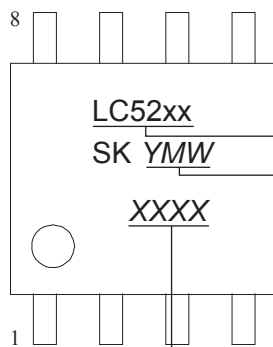

Part Number
Lot Number
Y is the last digit of the year (0 to 9)
M is the month (1 to 9, O, N, or D)
W is week code (1 to 3)

Sanken Control Number

Functional Description

PMW Current Control (Buck Converter)

- The polarity value for current specifies a sink as "+," and a source as "–," referencing the IC.
- All of the parameter values used in these descriptions are typical values, unless they are specified as minimum or maximum.

PWM On-Time Period

At startup, or during normal operation before the output current through the LED string reaches the target current level, the internal power MOSFET turns on and the output current flows through the I_{ON} path shown in figure 2.

Turning-Off Period

The output current through the LED string is equivalent to the current through the detection resistor, R_S , and thus the LED current is detected at the SEN pin as a voltage. When the SEN pin voltage, V_{SEN} , is equal to the REF pin voltage, V_{REF} , the internal power MOSFET turns off.

PWM Off-Time Period

When the internal power MOSFET turns off, the current recirculation diode, D_1 , is forward biased by the back electromotive force (BEMF) in the inductor, L_1 , and D_1 turns on. Then the energy stored in L_1 during PWM on-time flows through the recirculation path shown as I_{OFF} in figure 2.

Turning-On Period

After the fixed off-time, t_{OFF} , the internal power MOSFET turns on again, and the PWM on-time period repeats. The cycle is shown in figure 2 panel B.

Internal PWM Control Circuit

Figure 3 shows the internal PWM control circuit, and figure 4 shows the timing diagram of that circuit. When the power MOSFET turns on, both the load current and V_{SEN} across the current detection resistor R_S increase.

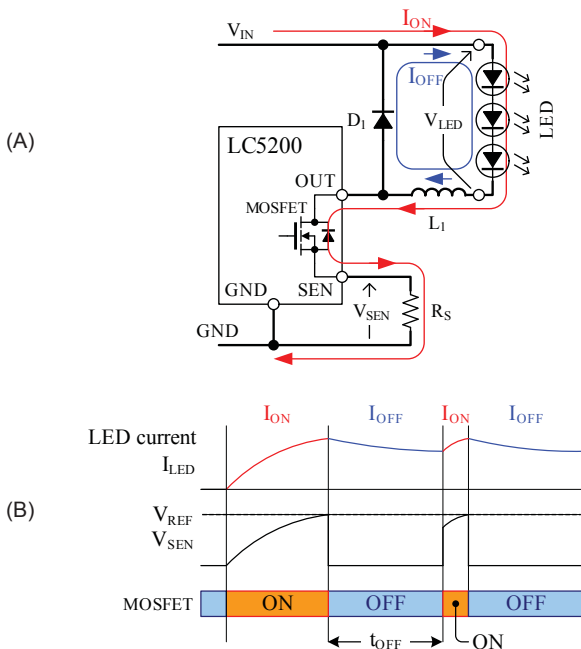

Figure 2. Current Control of Buck Converter

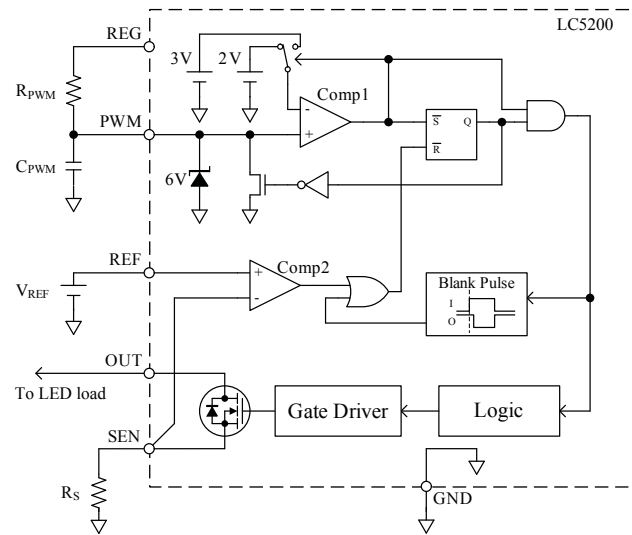

Figure 3. Current Control Circuit

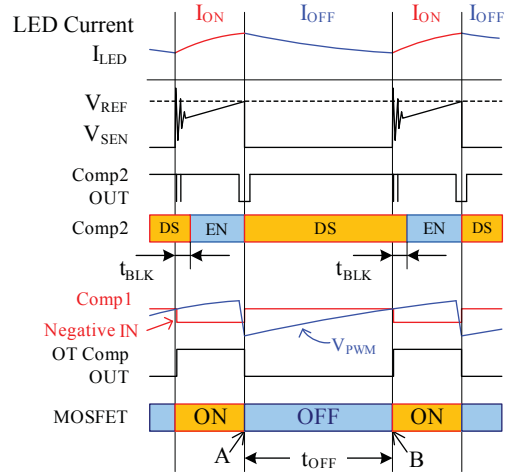

Figure 4. Current Control Circuit Timing Chart

Comp2 compares V_{SEN} and V_{REF} , and when $V_{REF} < V_{SEN}$, Comp2 inverts its output (see point A in figure 4). This resets the output Q of the RS flip-flop. After a turn-off signal is transmitted from the AND gate to the logic, to the gate driver, and finally to the internal power MOSFET, the power MOSFET turns off. At the same time, an internal MOS switch, connected to the PWM pin, turns on, and C_{PWM} is discharged.

After a certain period, when the PWM pin voltage, V_{PWM} , decreases to less than 2 V, the comparator for the off-time, Comp1, inverts and the Q output of the RS flip-flop is set. Then the MOS switch for discharging C_{PWM} turns off, and C_{PWM} is charged by the REF pin voltage through R_{PWM} (connected between the REF and PWM pins).

When V_{PWM} increases to more than 3 V, the fixed off-time expires and the power MOSFET turns on. After that, the operation reverts to the initial state, shown as point B in figure 4.

V_{SEN} is detected in the on-time period, except during the PWM blanking time, t_{BLK} , in order to prevent malfunction.

The fixed off-time is determined by R_{PWM} and C_{PWM} . Figure 5 shows PWM off-time curves based on various values of R_{PWM} and C_{PWM} . The recommended value for R_{PWM} is 560 k Ω , and that for C_{PWM} is 220 pF. In addition, the proper values for R_{PWM} and C_{PWM} are changeable according the load conditions of the LEDs used, and the value of R_{PWM} also affects the losses in the internal regulator directly. It is necessary to pay attention to these factors.

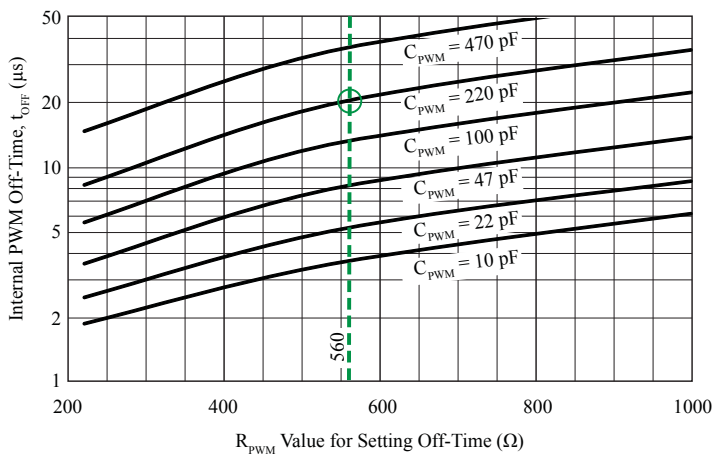

Figure 5. PWM Off-Time versus R_{PWM} Value, for Various Values of C_{PWM}

Current Value Setting for Dimming Control

The LC5200 series allows constant current control using the internal PWM control, an external PWM signal, or a combination of both of them.

Using Internal PWM Dimming

The LC5200 series has a built-in PWM constant current control circuit, and thus can achieve a constant current drive system for the LED string, while requiring few external components. The peak output current, I_{PEAK} , for driving the LED string is calculated as follows:

$$I_{PEAK} = \frac{V_{REF}}{R_S} = \frac{V_{REG} \times R_2}{R_S \times (R_1 + R_2)} \quad (1)$$

The LC5200 series allows external adjustment of the current flowing through the LED string, using either of the following methods:

- Adjusting the analog voltage on the REF pin (figure 6A)
- Inputting the analog voltage integrated PWM signal through a low pass filter, LPF, to the REF pin (figure 6B)

However, the dimming control by adjusting the REF pin voltage can not set the output current to zero. When controlling to zero current, an external signal and external circuit are needed to set the PWM pin voltage to low.

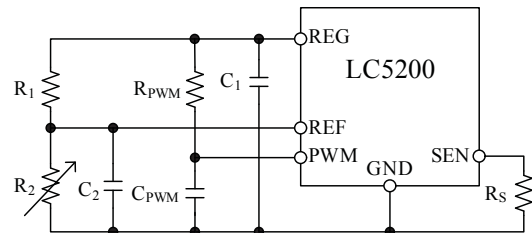

(A) Analog Control

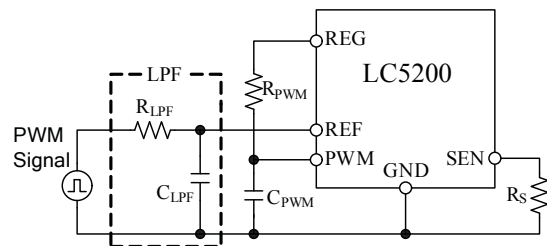

(B) Integrated PWM Control

Figure 6. Dimming Application Circuits with Internal PWM Control

Using External PWM Dimming

Using an external PWM signal allows applying the LC5200 series as a high voltage power switch. In this configuration, the output of the OUT pin turns on and off according to a logic signal input to the PWM pin. Because this control is not activated by the internal PWM current control circuit, an external current control circuit is needed. The frequency of the input PWM signal is recommended to be in the range 20 to 200 kHz.

As shown in figure 7, C_{PWM} and R_{PWM} are removed, and then the PWM signal is directly input to the PWM pin. The REF pin must be pulled up to the REG pin.

On the internal circuit of the PWM pin, there is a comparator with hysteresis. When the input signal on the PWM pin is 3 V, the comparator turns on the OUT pin, and when the input signal is 2 V, the comparator turns off the OUT pin. Because the internal circuit of the PWM pin has a built-in Zener diode of 6.3 V (typ) for protection, the PWM pin voltage is compatible with 5 V CMOS logic level.

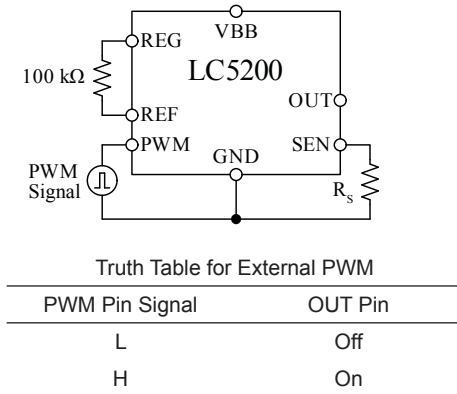

Figure 7. Dimming Application Circuit with External PWM Control

When the SEN pin voltage, V_{SEN} , reaches the OCP detection voltage, V_{OCP} , or more, the OCP function is activated.

Using Both Internal and External PWM Dimming

This configuration combines the two configurations described above: the internal PWM control circuit determines the limitation of the peak output current flowing through the LED string, and the external PWM circuit controls the average current. This configuration is effective for a low frequency external PWM range, 200 to 500 Hz. The application circuit is shown in figure 8.

The narrower the duty cycle of the external PWM signal is, the higher the average LED output current is. At a 100% duty cycle, the LED output current is 0 A. The timing diagram is shown in figure 9.

As shown in figure 8, the circuit has an added external MOS switch, and when the PWM pin signal goes low, the internal PWM current control is activated.

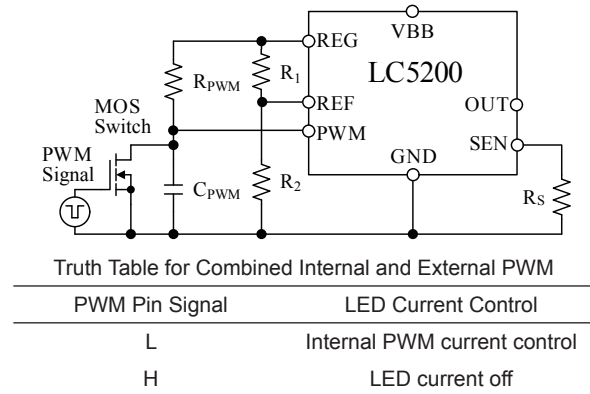

Figure 8. Dimming Application Circuit with Combined Internal and External PWM Control

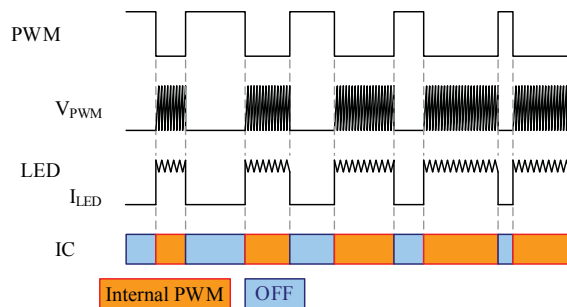

Figure 9. Timing for Combined Internal and External PWM Operation

Application Information

Typical Application Components

The typical application circuit for a buck configuration, shown in figure 1, is an example for a basic peripheral circuit. Table 1 provides reference specifications for the typical application circuit in figure 1, listing parts as examples for the sole purpose of reference for the initial use of the IC. The specifications are for typical values, and do not take into consideration application usage conditions such as PCB layout, LED types, or circuit noise. It is necessary to take account of such factors fully while designing the application, and component selection should be validated by operation in the actual application.

External Component Selection

The following recommendations should be observed when selecting components for use with the LC5200 series.

LEDs

The relationship between the LED ratings and the output current ratings of the IC should be considered. In a buck configuration, the total forward voltage drop, V_{LED} , of the LEDs in series

should be less than the VBB pin voltage, V_{BB} , because the LEDs would be turned off if V_{LED} were more than V_{BB} . Normally, a V_{LED} of 9 to 60 V is assumed.

L_1

This is an inductor for smoothing output current. When the inductance value of L_1 is relatively higher, the LED ripple current is lower, and thus current stability is improved. Normally, an L_1 value of 0.5 to 10 mH is assumed.

In actual operation, L_1 should be rated such that it is not saturated by the peak of the ripple current. If the inductor becomes saturated by an unexpectedly high surge current flow, the LEDs and the IC could be damaged.

D_1

This is a free-wheeling diode for recirculation of the output current. The energy stored during the PWM on-time period is provided to the LEDs through this diode during the off-time period. The withstand voltage and the recovery time, t_{RR} , should be considered.

Table 1. Reference Specification of the Typical Application Circuit

Input voltage: 100 VAC, LED output voltage: 5 LEDs in series (about 15 to 18 V total), LED peak output current: 0.35 A

Symbol	Part Type	Reference Values and Rating	Description
LED	LED	–	User-defined
L_1	Inductor	1 mH / 1 A	Choke coil for smoothing current
D_1	Fast Recovery Rectifier Diode	SJPD-L5	Free-wheeling diode for recirculation
C_{IN}	Capacitor	Up to 4.7 μ F / 450 V	Main supply source filtering capacitor
C_1	Capacitor	0.1 μ F / 25 V	Internal regulator stabilizing capacitor
C_2	Capacitor	0.1 μ F / 25 V	REF pin voltage stabilizing capacitor
R_{PWM}	Resistor	560 k Ω / 1/8 W	PWM off-time setting resistor for internal PWM control
C_{PWM}	Capacitor	220 pF / 25 V	PWM off-time setting capacitor for internal PWM control
R_1	Resistor	680 k Ω / 1/8 W	Resistor for setting peak output current on OUT pin
R_2	Resistor	20 k Ω / 1/8 W	Resistor for setting peak output current on OUT pin
R_S	Resistor	1.0 Ω / 1 W	Resistor for output current detection

If a diode with a long t_{RR} is selected, surge current may flow into the OUT pin when the internal power MOSFET turns on. If this were to occur, it would cause increased noise, potentially resulting in malfunction due to the noise, and decreased efficiency.

C_{IN}

This is an input smoothing capacitor. When the capacitance value of C_{IN} is relatively higher, the input and output ripple voltages are lower. However, given a certain capacitance level, the greater the output power is, the greater the ripple voltages are. Thus it is necessary to select the value according to the output power.

The IC is capable of operation, with V_{IN} full-wave rectification, with an input capacitor rated as low as approximately 1000 pF, instead of with an electrolytic capacitor. By allowing configuration without an electrolytic capacitor, the IC enhances power supply system operational life, and reduces system size and cost.

Note: If the lower peak of the ripple voltage of V_{IN} is allowed to fall below the UVLO Threshold (Turn off), $V_{UVLO(OFF)}$, or if the output voltage is less than V_{LED} , the LEDs are turned off. Thus it is necessary to take account of the value of C_{IN} .

C_1

This is a capacitor for stabilizing the internal regulator. It is required to provide the charge current for charging the gate of the internal power MOSFET, and to maintain a stable voltage. Normally, a ceramic capacitor of 0.1 μ F is used. A too-low value causes decreased switching speed and malfunctions. A too-high value causes a longer startup time because a long charging time for this capacitor delays startup for the power supply. These factors should be carefully evaluated.

The capacitor should be placed as close to the IC as possible.

R_1 , R_2 , and R_S

These resistors determine the peak output current, I_{PEAK} , flowing to the LEDs. The peak current value can be calculated as follows:

$$I_{PEAK} = \frac{V_{REF}}{R_S} = \frac{V_{REG} \times R_2}{R_S \times (R_1 + R_2)}$$

For example, to set I_{PEAK} to 0.35 A, assuming a REG pin voltage, V_{REG} , of 12 V, and resistances for R_1 of 680 k Ω , R_2 of 20 k Ω , and R_S of 1 Ω :

$$I_{PEAK} = \frac{12 \text{ (V)} \times 20 \text{ (k}\Omega\text{)}}{1 \text{ (}\Omega\text{)} \times (680 \text{ (k}\Omega\text{)} + 20 \text{ (k}\Omega\text{)})} = 0.343 \text{ A}$$

In actual operation, the current value is higher than that calculated by the above equation because there is some propagation delay in internal circuit. Especially when the input voltage is high and the inductance value is low, the di/dt slope of the current is high, and the actual current value is much higher than the calculated current value. The current flowing to R_1 and R_2 affects the losses in the internal regulator directly. Therefore it is recommended to select R_1 and R_2 such that 500 k Ω < $R_1 + R_2$, in order to restrict current as much as possible.

It is recommended that the detection resistor, R_S , have an allowable power dissipation that is twice to three times as much as the loss in R_S as margin, because the output current flows to it when the internal power MOSFET turns on, and the loss may be comparatively large.

R_{PWM} and C_{PWM}

Refer to the PWM Current Control (Buck Converter) section.

Because reliability can be affected adversely by improper storage environments and handling methods, please observe the following cautions.

Cautions for Storage

- Ensure that storage conditions comply with the standard temperature (5°C to 35°C) and the standard relative humidity (around 40% to 75%); avoid storage locations that experience extreme changes in temperature or humidity.
- Avoid locations where dust or harmful gases are present and avoid direct sunlight.
- Reinspect for rust on leads and solderability of the products that have been stored for a long time.

Cautions for Testing and Handling

When tests are carried out during inspection testing and other standard test periods, protect the products from power surges from the testing device, shorts between the product pins, and wrong connections. Ensure all test parameters are within the ratings specified by Sanken for the products.

Soldering

- When soldering the products, please be sure to minimize the working time, within the following limits:
 - DIP8
 - Flow soldering:
260±5°C 10±1 s (2 times)
 - Soldering iron:
380±10°C 3.5±0.5 s (1 time)
 - Soldering should be at a distance of at least 1.5 mm from the body of the products.
 - SOP8
 - Reflow soldering:
180°C 90±30 s for preheating
250°C 10±1 s (260°C peak, 2 times) for solder heating
 - Soldering iron:
380±10°C 3.5±0.5 s (1 time)
- Note: Flow soldering must not be used.

Electrostatic Discharge

- When handling the products, the operator must be grounded. Grounded wrist straps worn should have at least 1 MΩ of resistance from the operator to ground to prevent shock hazard, and it should be placed near the operator.
- Workbenches where the products are handled should be grounded and be provided with conductive table and floor mats.
- When using measuring equipment such as a curve tracer, the equipment should be grounded.
- When soldering the products, the head of soldering irons or the solder bath must be grounded in order to prevent leak voltages generated by them from being applied to the products.
- The products should always be stored and transported in Sanken shipping containers or conductive containers, or be wrapped in aluminum foil.

-
- The contents in this document are subject to changes, for improvement and other purposes, without notice. Make sure that this is the latest revision of the document before use.
 - Application and operation examples described in this document are quoted for the sole purpose of reference for the use of the products herein and Sanken can assume no responsibility for any infringement of industrial property rights, intellectual property rights or any other rights of Sanken or any third party which may result from its use.
 - Although Sanken undertakes to enhance the quality and reliability of its products, the occurrence of failure and defect of semiconductor products at a certain rate is inevitable. Users of Sanken products are requested to take, at their own risk, preventative measures including safety design of the equipment or systems against any possible injury, death, fires or damages to the society due to device failure or malfunction.
 - Sanken products listed in this document are designed and intended for the use as components in general purpose electronic equipment or apparatus (home appliances, office equipment, telecommunication equipment, measuring equipment, etc.).

When considering the use of Sanken products in the applications where higher reliability is required (transportation equipment and its control systems, traffic signal control systems or equipment, fire/crime alarm systems, various safety devices, etc.), and whenever long life expectancy is required even in general purpose electronic equipment or apparatus, please contact your nearest Sanken sales representative to discuss, prior to the use of the products herein.

The use of Sanken products without the written consent of Sanken in the applications where extremely high reliability is required (aerospace equipment, nuclear power control systems, life support systems, etc.) is strictly prohibited.

- In the case that you use Sanken products or design your products by using Sanken products, the reliability largely depends on the degree of derating to be made to the rated values. Derating may be interpreted as a case that an operation range is set by derating the load from each rated value or surge voltage or noise is considered for derating in order to assure or improve the reliability. In general, derating factors include electric stresses such as electric voltage, electric current, electric power etc., environmental stresses such as ambient temperature, humidity etc. and thermal stress caused due to self-heating of semiconductor products. For these stresses, instantaneous values, maximum values and minimum values must be taken into consideration.

In addition, it should be noted that since power devices or IC's including power devices have large self-heating value, the degree of derating of junction temperature affects the reliability significantly.

- When using the products specified herein by either (i) combining other products or materials therewith or (ii) physically, chemically or otherwise processing or treating the products, please duly consider all possible risks that may result from all such uses in advance and proceed therewith at your own responsibility.
- Anti radioactive ray design is not considered for the products listed herein.
- Sanken assumes no responsibility for any troubles, such as dropping products caused during transportation out of Sanken's distribution network.
- The contents in this document must not be transcribed or copied without Sanken's written consent.