



# PRODUCT SPECIFICATION

*Part Number*  
**PLC5C-WCW01**

## *Details*

- 5mm (T1 3/4) Round Thru-Hole LED
- Emitting Color: White
- InGaN Dice Used
- Water Clear Epoxy Resin

## *Features*

- RoHS Compliant
- Low Power Consumption
- High Luminous Output
- Optimal Optical/Mechanical Design

## *Mechanical Dimensions*

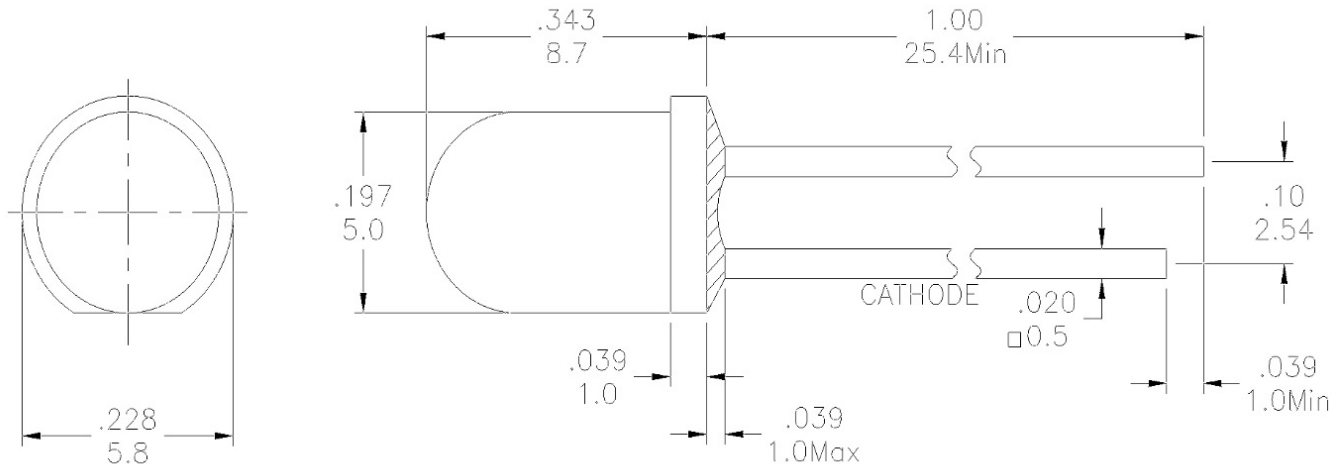

### Notes:

1. All dimensions are in millimeters unless otherwise noted
2. Tolerance is  $\pm 0.25$  mm unless otherwise noted





**Device Selection Guide**

Part Number	Chip		Lens Type
	Material	Emitting Color	
PLC5C-WCW05	InGaN	White	Water Clear

**Absolute Maximum Ratings at Ta=25 °C**

Parameter	Symbol	Rating	Unit
Power Dissipation	P <sub>D</sub>	76	mW
Reverse Voltage	V <sub>R</sub>	5	V
DC Forward Current	I <sub>F</sub>	30	mA
Peak Forward Current (Pulse width ≤0.1 msec. duty ≤1/10)	I <sub>PF</sub>	100	mA
Operating Temperature	T <sub>opr</sub>	-30~+80	°C
Storage Temperature	T <sub>stg</sub>	-40~+100	°C
Lead Soldering Temperature	T <sub>sol.</sub>	Max. 260°C for 5 sec Max. (3mm from the epoxy body)	

**Electrical and Optical Characteristics at Ta=25 °C**

Parameter	Symbol	Min.	Typ.	Max.	Unit	Condition
Forward Voltage	V <sub>F</sub>	--	3.2	3.6	V	I <sub>F</sub> =20mA
Luminous Intensity	I <sub>v</sub>	8600	18250	--	mcd	
Chromaticity Coordinates	X	--	0.31	--	--	
	Y	--	0.32	--	--	
Viewing Angle	2θ <sub>1/2</sub>	--	15	--	--	deg
Reverse Current	I <sub>r</sub>	--	--	50	μA	V <sub>R</sub> =5V

### Luminous Intensity Rank Limits (IF = 20mA)

Code	Min.	Max.
36	8600	11200
37	11200	14600
38	14600	19000
39	19000	24700
40	24700	32100

### Color Rank Limits (IF = 20mA)

Rank A Color Temperature:9000-15000K										
A										
X	0.28	0.264	0.283	0.296	0.28					
Y	0.248	0.267	0.305	0.276	0.248					

Rank B Color Temperature: 7000-9000K											
B1					B2						
X	0.287	0.283	0.304	0.307	0.287	X	0.296	0.287	0.307	0.311	0.296
Y	0.295	0.305	0.33	0.315	0.295	Y	0.276	0.295	0.315	0.294	0.276

Rank C Color Temperature:5500-7000K											
C1					C2						
X	0.307	0.304	0.33	0.33	0.307	X	0.311	0.307	0.33	0.33	0.311
Y	0.315	0.33	0.36	0.339	0.315	Y	0.294	0.315	0.339	0.318	0.294

Rank D Color Temperature:4600-5500K										
D1					D2					
X	0.33	0.33	0.361	0.356	0.33					
Y	0.318	0.36	0.385	0.351	0.318					

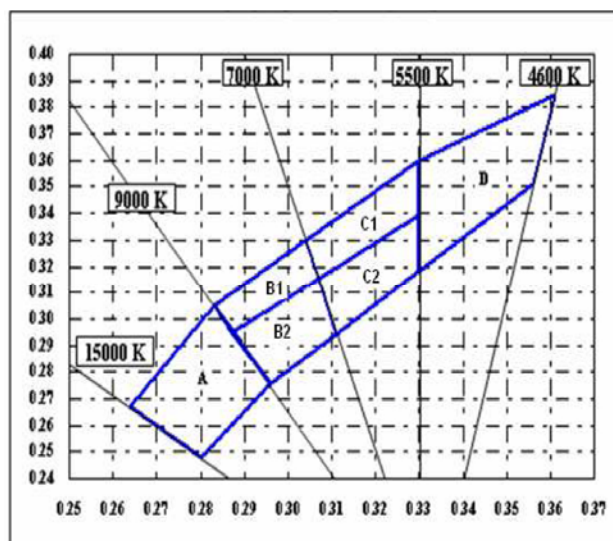

### Forward Voltage Rank Limits (IF = 20mA)

Code	Min.	Max.
H	2.8	3.0
J	3.0	3.2
K	3.2	3.4
L	3.4	3.6

Notes:

1. Tolerance of measurement of luminous intensity:  $\pm 15\%$
2. Tolerance of measurement of Color Coordinates:  $\pm 0.01$
3. Tolerance of measurement of forward voltage:  $\pm 0.05v$
4. All data are measured by factory test equipment.
5. One delivery will include several color rank, VF rank and Iv ranks of the products.
6. The quantity-ratio of the ranks is decided by P-tec.
7. Please confirm with P-tec if your request differs from standard specification

*Typical Electrical / Optical Characteristic Curves*

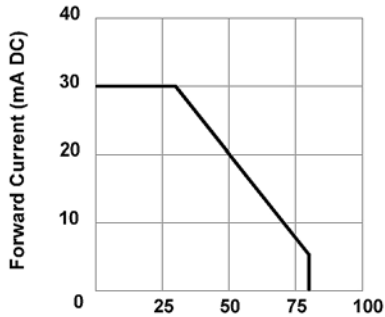

Ambient Temperature Ta (°C)  
**Fig 1. Forward Current Vs. Ambient Temperature**

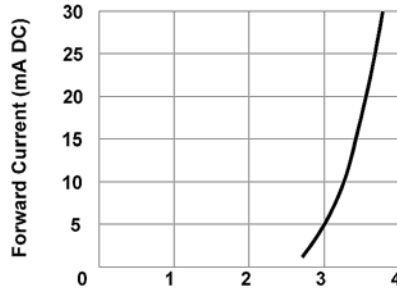

Forward Voltage VF (V)  
**Fig 2. Forward Current Vs. Forward Voltage**

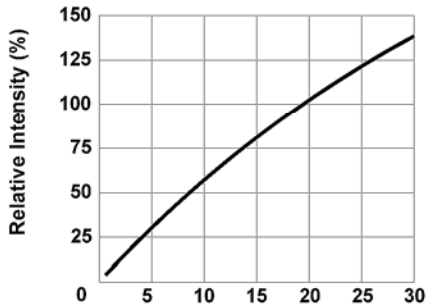

Forward Current IF (mA DC)  
**Fig 3. Relative Intensity Vs. Forward Current**



Forward Voltage (V)  
**Fig 4. Peak Forward Voltage Vs. Forward Current (100us test pulse, 1% duty cycle)**

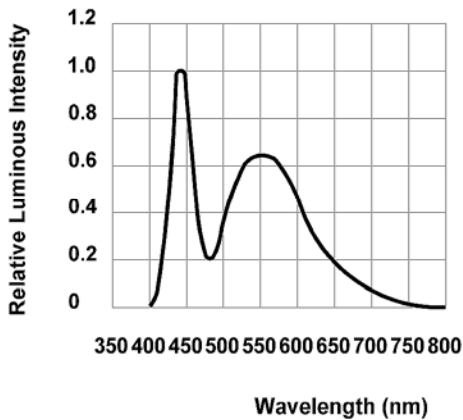

**Fig 5. Relative Intensity Vs. Wavelength**

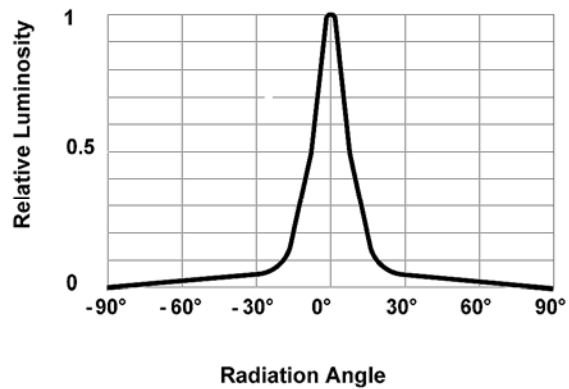
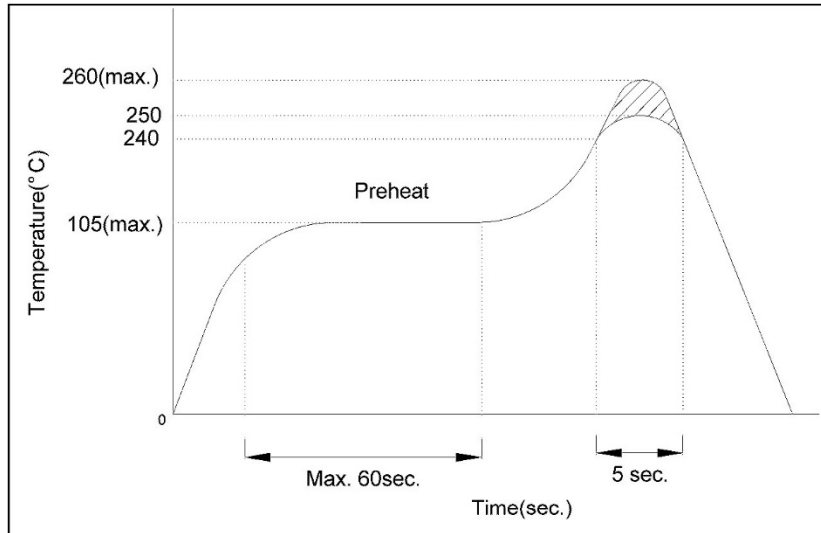

**Fig 6. Relative Luminous Intensity vs. Radiation Angle**

## *Precautions for Use*

### 1. Recommended Soldering conditions

#### Wave Soldering



### 2. Soldering Iron

Basic SPEC. is  $\leq 5$ sec. When  $260^{\circ}\text{C}$ . If temperature is higher, time should be shorter ( $+10^{\circ}\text{C} \rightarrow -1$ sec.). Power dissipation of iron should be smaller than 15W, and temperature should be controllable. Surface temperature of the device should be under  $230^{\circ}\text{C}$ .

### 3. Static Electricity

- a. Static electricity or surge voltage damages LEDs..

It is recommended that a wrist band or an anti-electrostatic glove be used when handling the LEDs.

- b. All devices, equipment and machinery must be properly grounded. It is recommended that measures be taken against surge voltage to the equipment that mounts the LEDs.



	Approved By	Checked By	Prepared By
Customer Approval Signatures			

Record Of Revisions			
Rev.	Comments	Page	Date
0	Released Spec	--	07/03/14