

General Description

This Trench MOSFET has better characteristics, such as fast switching time, low on resistance, low gate charge and excellent avalanche characteristics. It is mainly suitable for portable equipment and Load Switch.

FEATURES

- $V_{DSS} = -30V$, $I_D = -7.1A$
- Drain-Source ON Resistance
 $R_{DS(ON)} = 25m$ (Max.) @ $V_{GS} = -10V$
 $R_{DS(ON)} = 41m$ (Max.) @ $V_{GS} = -4.5V$
- Super Hige Dense Cell Design

MAXIMUM RATING (Ta=25)

CHARACTERISTIC		SYMBOL	P-Ch	UNIT
Drain-Source Voltage		V_{DSS}	-30	V
Gate-Source Voltage		V_{GSS}	± 20	V
Drain Current	DC@ $T_A=25$	I_D	-7.1	A
	DC@ $T_A=70$		-5.7	
	Pulsed	I_{DP}	-40	
Drain-Source-Diode Forward Current		I_S	-1.7	A
Drain Power Dissipation	$T_A=25$	P_D	1.1	W
	$T_A=70$		0.7	
Maximum Junction Temperature		T_j	150	
Storage Temperature Range		T_{stg}	-55 150	
Thermal Resistance, Junction to Ambient		R_{thJA}	110	/W

Note : Surface Mounted on FR4 Board, t 10sec.

PIN CONNECTION (TOP VIEW)

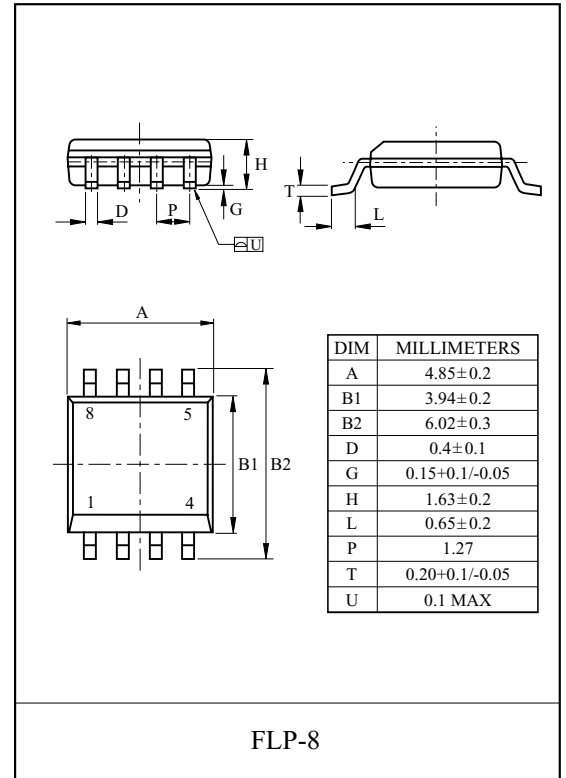
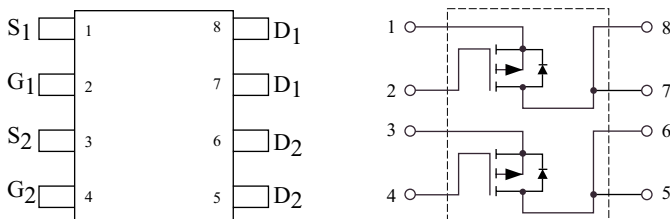

Marking

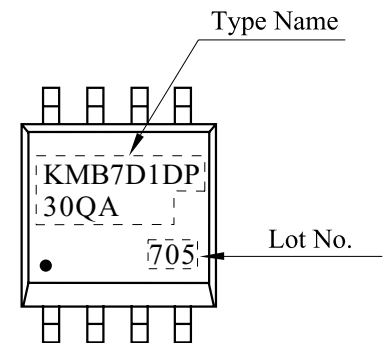

KMB7D1DP30QA

ELECTRICAL CHARACTERISTICS (Ta=25)

CHARACTERISTIC	SYMBOL	TEST CONDITION	MIN.	TYP.	MAX.	UNIT
Static						
Drain-Source Breakdown Voltage	BV_{DSS}	$I_{DS}=-10\ \mu A, V_{GS}=0V,$	-30	-	-	V
Drain Cut-off Current	I_{DSS}	$V_{GS}=0V, V_{DS}=-30V$	-	-	-1	μA
		$V_{GS}=0V, V_{DS}=-30V, T_j=55$	-	-	-25	
Gate Leakage Current	I_{GSS}	$V_{GS}=\pm 20V, V_{DS}=0V$	-	-	± 100	nA
Gate Threshold Voltage	V_{th}	$V_{DS}=V_{GS}, I_D=-250\ \mu A$	-1	-	-3	V
Drain-Source ON Resistance	$R_{DS(ON)}^*$	$V_{GS}=-10V, I_D=-7.1A$	-	20	25	m
		$V_{GS}=-4.5V, I_D=-5.5A$	-	33	41	
Forward Transconductance	g_{fs}^*	$V_{DS}=-10V, I_D=-7.1A$	-	20	-	S
Dynamic						
Input Capacitance	C_{iss}	$V_{DS}=15V, f=1MHz, V_{GS}=0V$	-	1550	-	pF
Output Capacitance	C_{oss}		-	420	-	
Reverse Transfer Capacitance	C_{rss}		-	380	-	
Total Gate Charge	Q_g^*	$V_{DS}=-15V, V_{GS}=-10V, I_D=-7.1A$	-	33	50	nC
Gate-Source Charge	Q_{gs}^*		-	5.4	-	
Gate-Drain Charge	Q_{gd}^*		-	8.9	-	
Turn-On Delay Time	$t_{d(on)}^*$	$V_{DD}=-15V, V_{GS}=-10V$ $I_D=-1A, R_G=6$	-	9	15	ns
Turn-On Rise Time	t_r^*		-	12	20	
Turn-Off Delay Time	$t_{d(off)}^*$		-	60	90	
Turn-Off Fall Time	t_f^*		-	34	50	
Source-Drain Diode Ratings						
Source-Drain Forward Voltage	V_{SDF}^*	$V_{GS}=0V, I_{DR}=-1.7A$	-	-0.8	-1.2	V
* : Pulse Test : Pulse width $300\ \mu s$, Duty cycle <math>< 2\%</math>						

KMB7D1DP30QA

Fig1. $V_{DS} - I_D$

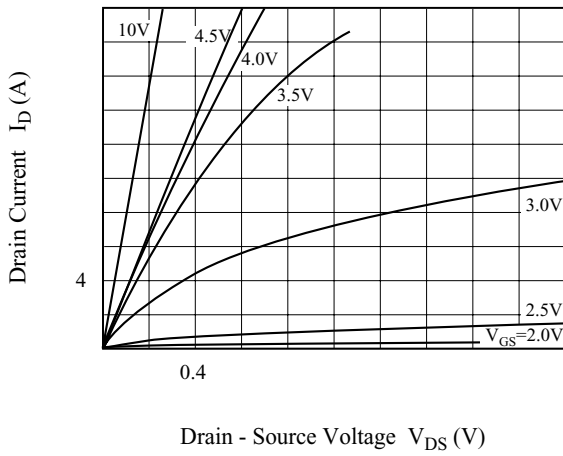

Fig2. $R_{DS(ON)} - I_D$

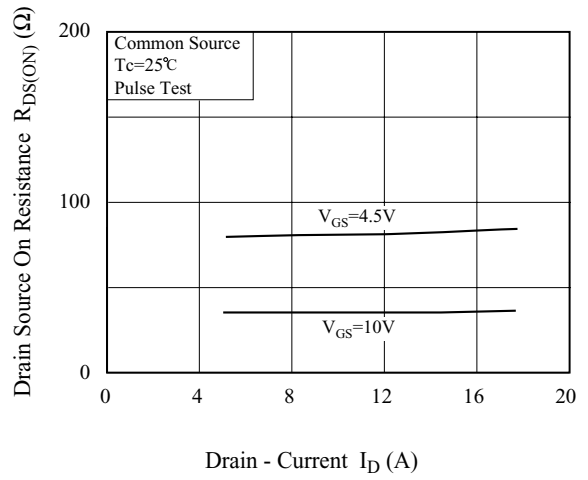

Fig3. $V_{GS} - I_D$

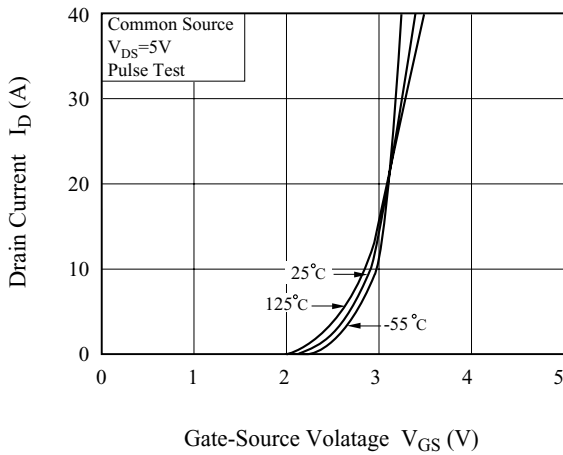

Fig4. $R_{DS(on)} - T_j$

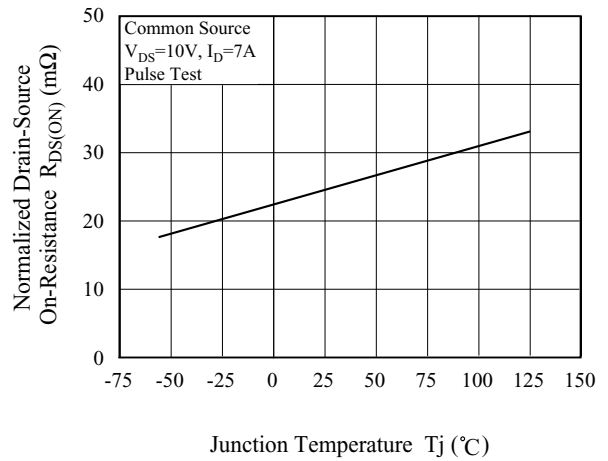

Fig5. $V_{th} - T_j$

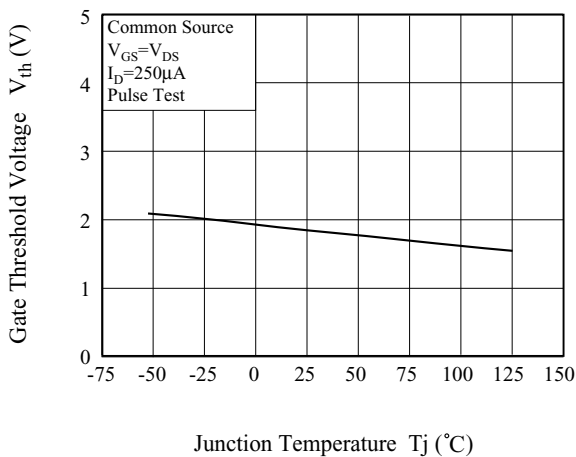
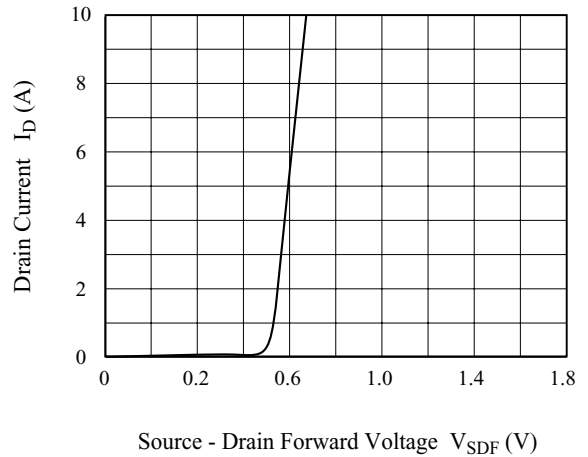

Fig6. $I_S - V_{SDF}$



KMB7D1DP30QA

Fig7. Transient Thermal Response Curve

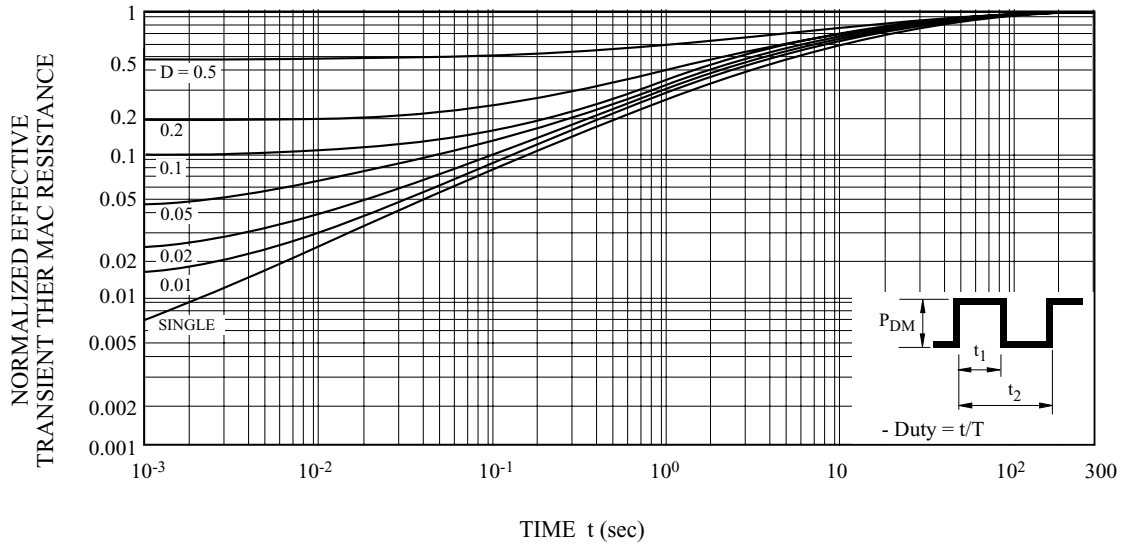
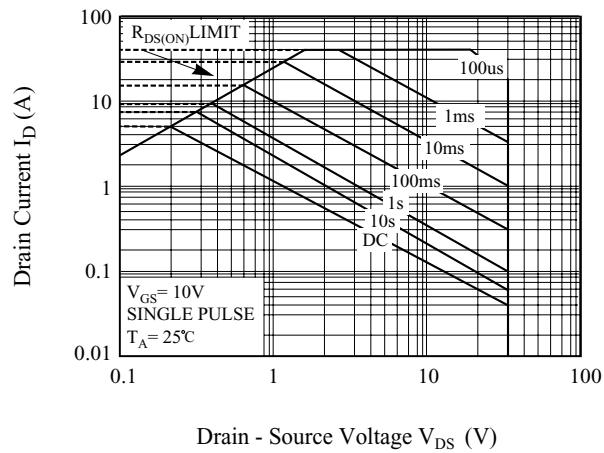

Fig8. Safe Operation Area



KMB7D1DP30QA

Fig9. Gate Charge Circuit and Wave Form

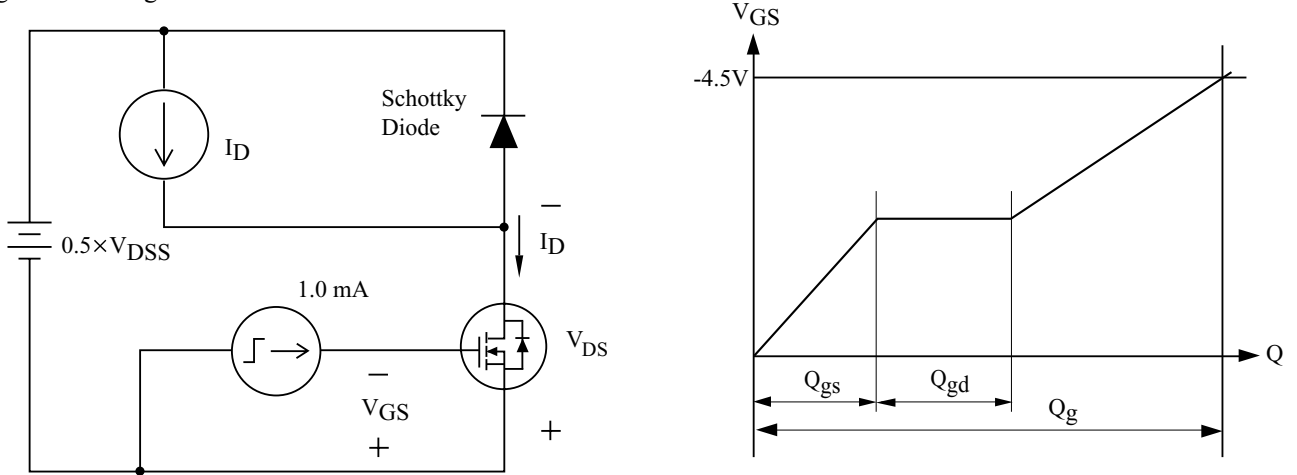

Fig10. Resistive Load Switching

