



TAI-SAW TECHNOLOGY CO., LTD.

No. 3, Industrial 2nd Rd., Ping-Chen Industrial District,
Taoyuan, 324, Taiwan, R.O.C.

TEL: 886-3-4690038 FAX: 886-3-4697532

E-mail: tstsales@mail.taisaw.com Web: www.taisaw.com

Product Specifications Approval Sheet

Product Description: SAW Filter 938 MHz SMD 3.0x3.0 mm

TST Part No.: TA1286A

Customer Part No.: _____

Customer signature required
Company: _____
Division: _____
Approved by : _____
Date: _____

Checked by: _____ David Chang 張開智

Approved by: _____ Francis Chen 

Date: _____ 2010/12/14

1. Customer signed back is required before TST can proceed with sample build and receive orders.
2. Orders received without customer signed back will be regarded as agreement on the specifications.
3. Any specifications changes must be approved upon by both parties and a new revision of specifications shall be released to reflect the changes.



TAI-SAW TECHNOLOGY CO., LTD.

No. 3, Industrial 2nd Rd., Ping-Chen Industrial District,
Taoyuan, 324, Taiwan, R.O.C.

TEL: 886-3-4690038 FAX: 886-3-4697532

E-mail: tstsales@mail.taisaw.com Web: www.taisaw.com

SAW Filter 938 MHz

MODEL NO.:TA1286A

REV. NO.:1

A. MAXIMUM RATING:

1. Input Power Level: 16 dBm
2. DC Voltage : 3V
3. Operating Temperature: -30°C to +85°C
4. Storage Temperature: -40°C to +95°C

RoHS Compliant
Lead free
Lead-free soldering

B. ELECTRICAL CHARACTERISTICS:

Item	Unit	Min.	Typ.	Max.
Center Frequency Fc	MHz	-	938	-
Insertion loss (935~941MHz)	dB	-	2.5	3.7
Amplitude ripple (935~941MHz)	dB	-	0.2	1.4
VSWR (935~941MHz)	-	-	1.5	2.2
Attenuation (Reference level from 0 dB)				
40 ~ 400 MHz	dB	40	63	-
700 ~ 850 MHz	dB	20	52	-
893 ~ 910 MHz	dB	15	50	-
965 ~ 983 MHz	dB	25	49	-
1076 ~ 1092 MHz	dB	45	51	-
1100 ~ 1600 MHz	dB	45	48	-
1600 ~ 3000 MHz	dB	30	33	-
Temperature coefficient of frequency	ppm/k	-	-36	-

C. MEASUREMENT CIRCUIT:

HP Network analyzer

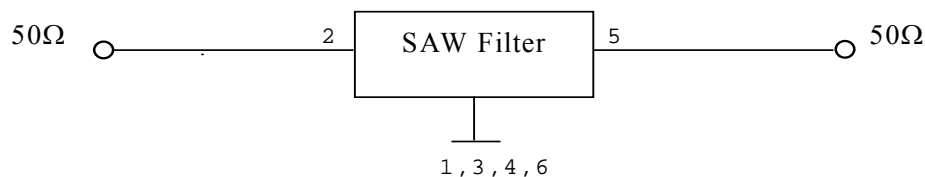

D. OUTLINE DRAWING:

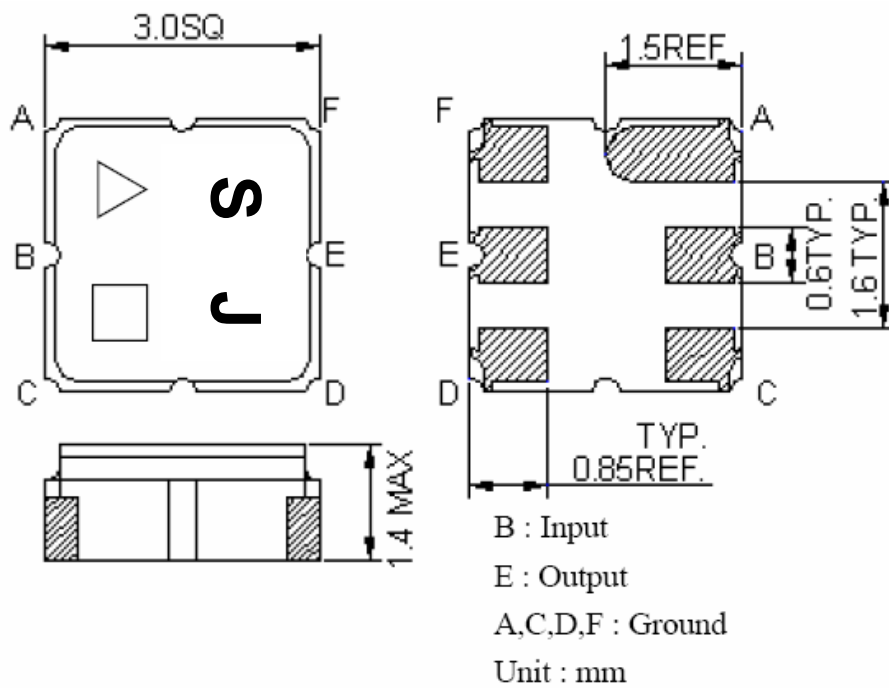

△ : Year Code (2006->6, ..., 2009->9)

□ : Date Code (W01->A,W02->B,...W27->a,...,W52->z)

E. PCB Footprint:

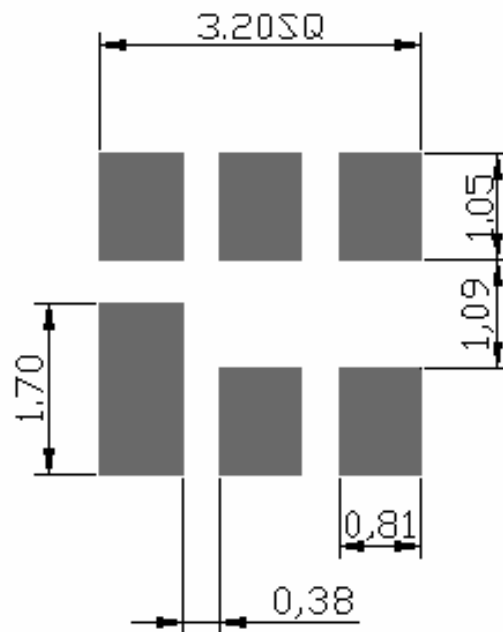

F. Frequency Characteristics:

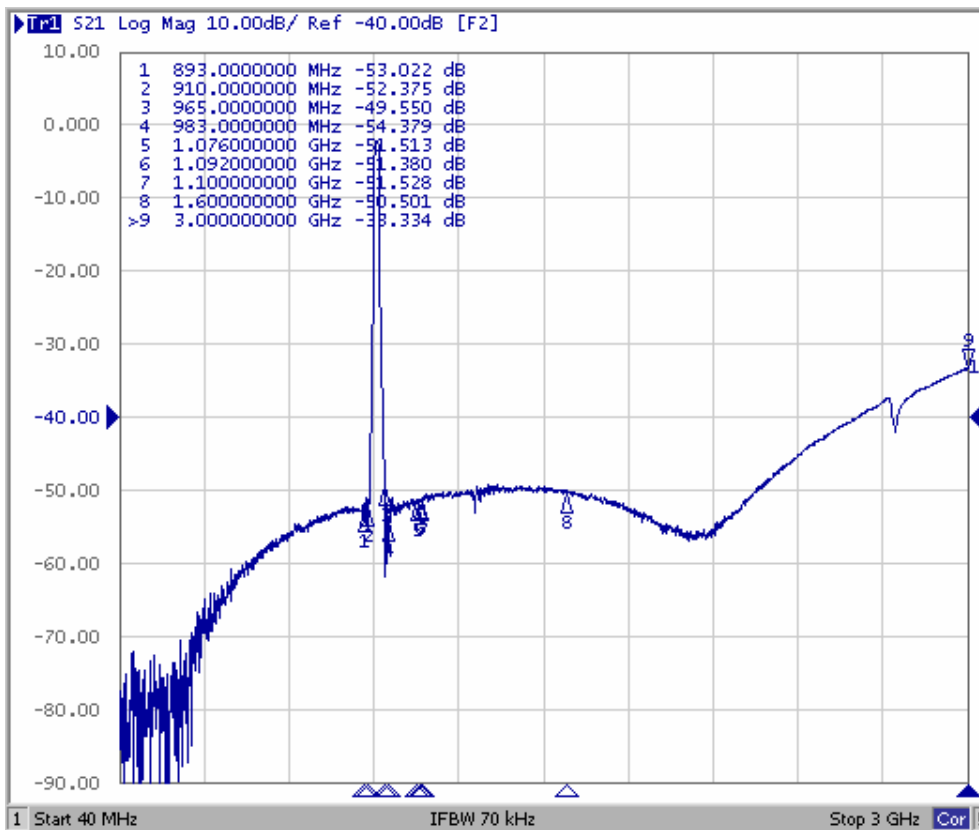
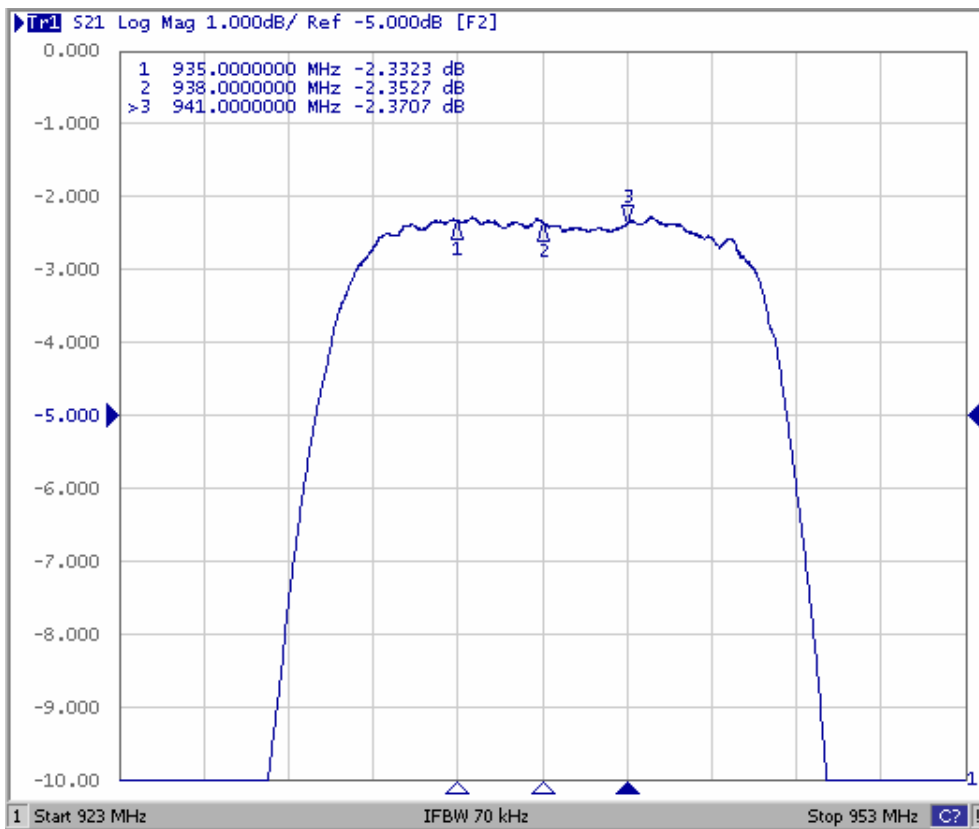

Reflection Functions:

S11

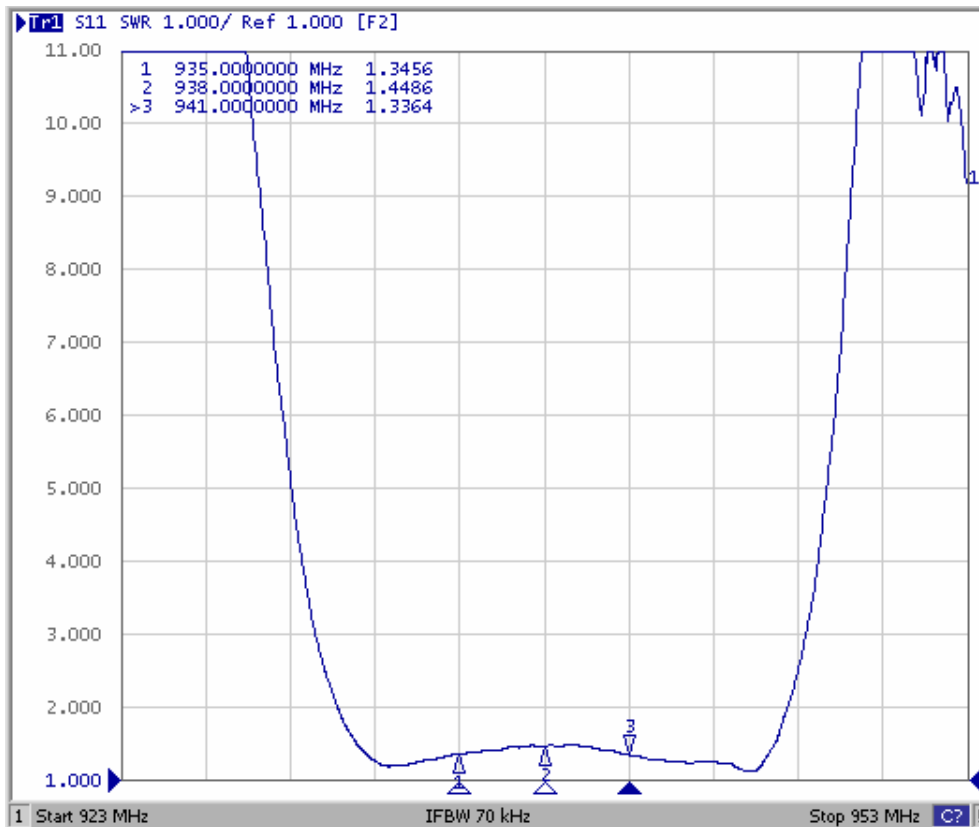

S22

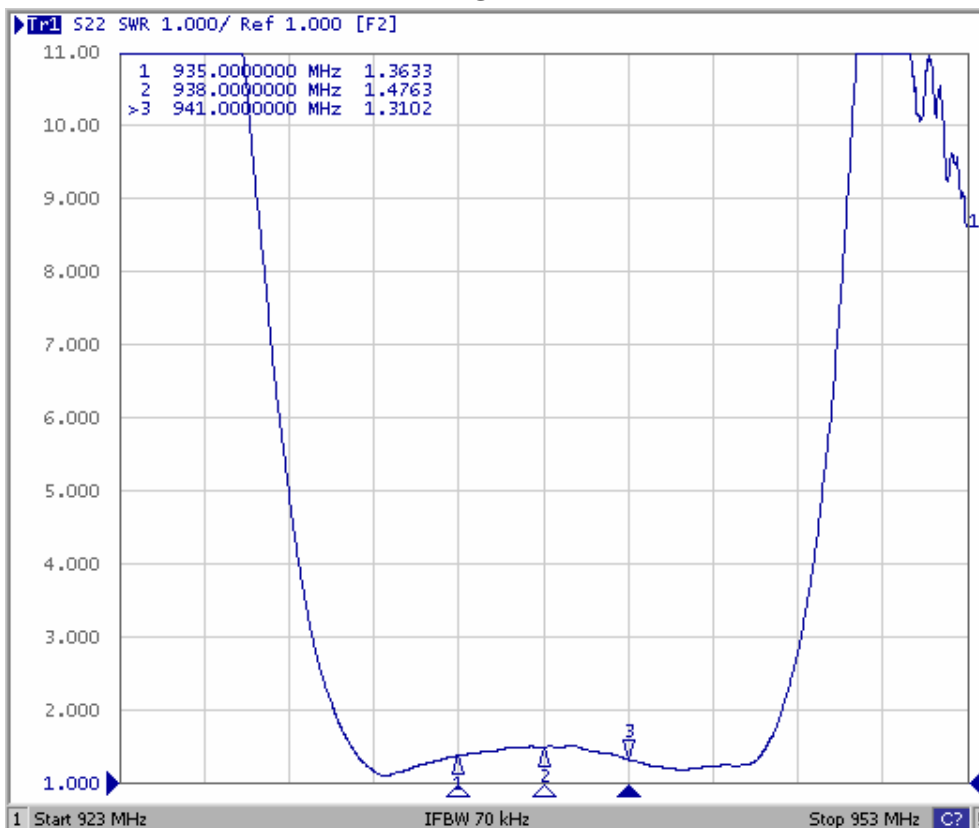

G. PACKING:

1. REEL DIMENSION

(Reel Count : 7"=1000 ; 13"=3000)

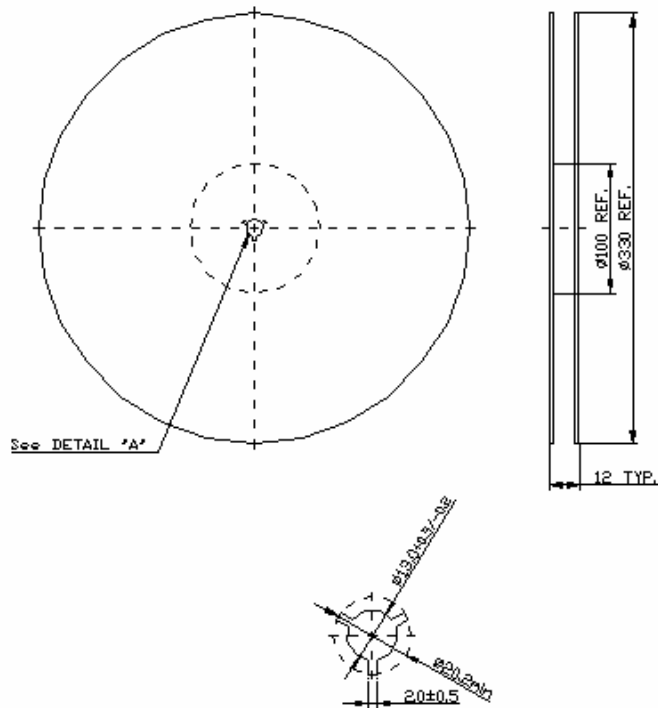

2. TAPE DIMENSION

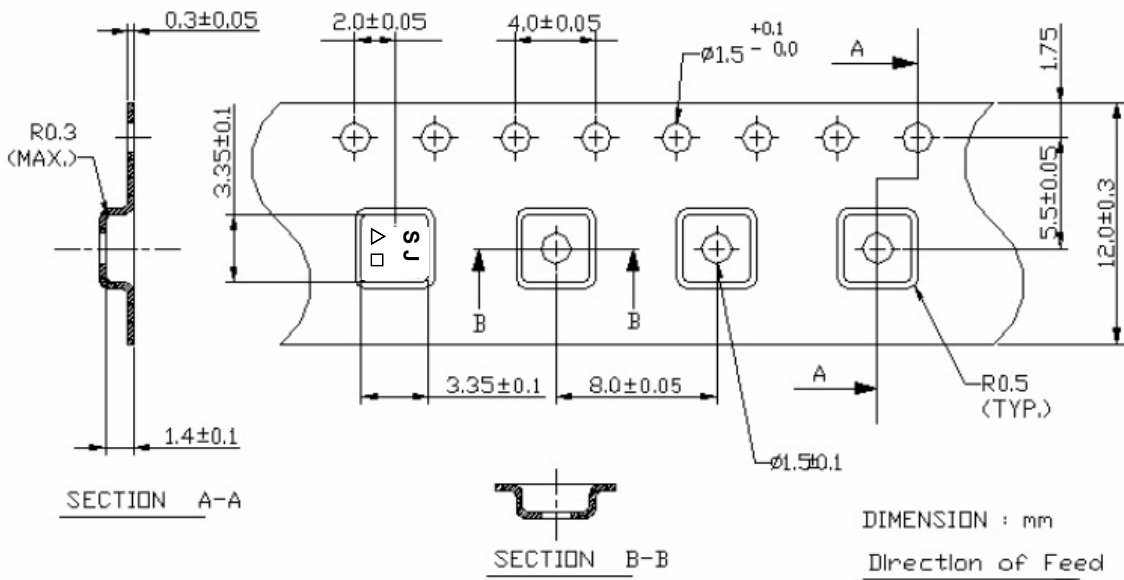

H. RECOMMENDED REFLOW PROFILE:

