

HFE19-60

MINIATURE HIGH POWER LATCHING RELAY



Features

- 60A switching capability
- Latching relay
- Making test 1800A peak short circuit current
- Carrying the 3500A short circuit current without explosion
- 4kV dielectric strength (between coil and contact)
- Environmental friendly product (RoHS compliant)
- Outline Dimensions: (38.0 x 30.0 x 16.5) mm

CONTACT DATA

Contact arrangement	1A, 1B
Contact resistance	1mΩ max.(at 1A 24VDC)
Contact material	AgSnO ₂
Contact rating (Res. load)	60A 250VAC
Max. switching voltage	250VAC
Max. switching current	60A
Max. switching power	22500VA
Mechanical endurance	Meter: 1 x 10 ⁵ OPS
Electrical endurance	Meter: 6000 OPS

CHARACTERISTICS

Insulation resistance	1000MΩ (at 500VDC)	
Dielectric strength	Between coil & contacts	4000VAC 1min
	Between open contacts	1500VAC 1min
Creepage distance	8mm	
Operate time (at nomi. volt.)	20ms max.	
Release time (at nomi. volt.)	20ms max.	
Shock resistance	Functional	98m/s ²
	Destructive	980m/s ²
Vibration resistance	10Hz to 55Hz 1.5mm DA	
Humidity	5% to 85% RH	
Ambient temperature	-40°C to 70°C	
Termination	QC	
Unit weight	Approx. 50g	
Construction	Dust protected	

Notes: The data shown above are initial values.

COIL

Coil power	Single coil latching: Approx. 1.0 W
	Double coils latching: Approx. 2.0 W

COIL DATA

at 23°C

Single coil latching

Nominal Voltage VDC	Set / Reset Voltage VDC max.	Pulse Duration ms min.	Coil Resistance x (1±10%) Ω
9	6.3	100	80
12	8.4	100	145
24	16.8	100	575
48	33.6	100	2270

Double coils latching

Nominal Voltage VDC	Set / Reset Voltage VDC max.	Pulse Duration ms min.	Coil Resistance x (1±10%) Ω
9	6.3	100	40+40
12	8.4	100	72+72
24	16.8	100	285+285
48	33.6	100	1135+1135



HONGFA RELAY

ISO9001, ISO/TS16949, ISO14001, OHSAS18001, IECQ QC 080000 CERTIFIED

2015 Rev. 1.00

ORDERING INFORMATION

	HFE19		-60/	12	-D	T	-2	1	-R	(XXX)
Type										
Contact rating	60: 60A									
Coil voltage	9, 12, 24, 48VDC									
Contact form¹⁾	D: 1 Form B H: 1 Form A									
Contact material	T: AgSnO₂									
Coil angle form	2: Distance 5mm; No bowleg 4: Distance 5mm; L-bowleg									
Sort	1: Single coil latching					2: Double coils latching				
Polarity	R: Negative polarity					Nil: Positive polarity				
Special code³⁾	XXX: Customer special requirement					Nil: Standard				

Notes: 1) H means that relay is on the "reset" status when delivery; D means that relay is on the "set" status when delivery. If no special required by customer, we will keep the relay on the "set" status when delivery.

2) we can make special design according to customer's requirement.

3) The customer special requirement express as special code after evaluating by Hongfa.

OUTLINE DIMENSIONS, WIRING DIAGRAM AND PC BOARD LAYOUT

Unit: mm

Outline Dimensions

1 coil latching

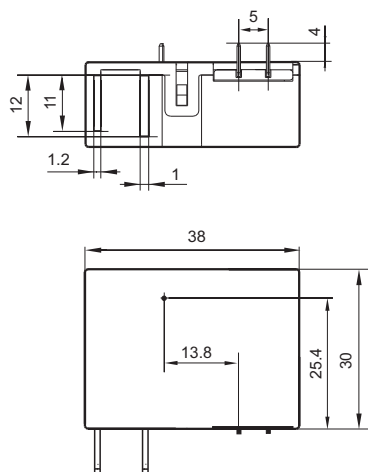

2 coils latching

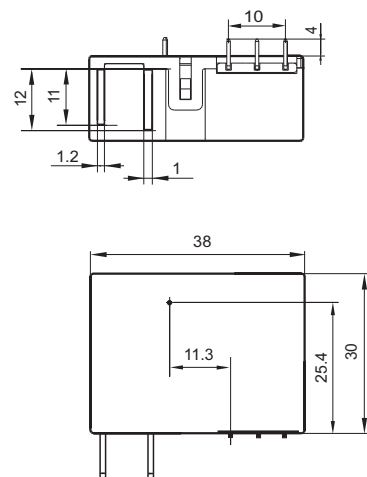

Remark: 1) In case of no tolerance shown in outline dimension: outline dimension ≤ 1 mm, tolerance should be ± 0.2 mm; outline dimension > 1 mm and ≤ 5 mm, tolerance should be ± 0.3 mm; outline dimension > 5 mm, tolerance should be ± 0.4 mm.

2) The tolerance without indicating for PCB layout is always ± 0.1 mm.

PCB Layout (Bottom view)



Wiring Diagram (Bottom view)



Positive polarity

Negative polarity

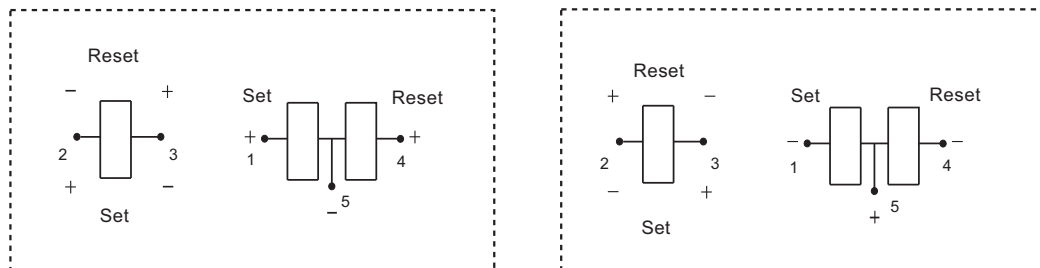

Notice

1. Relay is on the "reset" or "set" status when being released from stock, with the consideration of shock risen from transit and relay mounting, relay would be changed to "set" or "reset" status, therefore, when application (connecting the power supply), please reset the relay to "set" or "reset" status on request.
2. In order to maintain "set" or "reset" status, energized voltage to coil should reach the rated voltage, impulse width should be 5 times more than "set" or "reset" time. Do not energize voltage to "set" coil and "reset" coil simultaneously. And also long energized time (more than 1 min) should be avoided.
3. The terminals of relay without twisted copper wire can not be tin-soldered, can not be moved willfully.
4. Relays used for metering measuring applications are usually made with dust proof structure, while most relays could be made specially per customer's specific requirements.No longer than 6 months' storage time is recommended for this kind of relay, and please pay attention to the storage environment. To ensure contact reliability, we will keep contact status be closed when delivery if no special required by customer.

Disclaimer

The specification is for reference only. See to "Terminology and Guidelines" for more information. Specifications subject to change without notice. We could not evaluate all the performance and all the parameters for every possible application. Thus the user should be in a right position to choose the suitable product for their own application. If there is any query, please contact Hongfa for the technical service. However, it is the user's responsibility to determine which product should be used only.

© Xiamen Hongfa Electroacoustic Co., Ltd. All rights of Hongfa are reserved.