



TNC Male Right Angle Connector Clamp/Solder Attachment
for RG213, RG214, RG8, RG9, RG11, RG225, RG393

TECHNICAL DATA SHEET

PE4146

Configuration

Connector	TNC Male
Connector Specification	MIL-STD-348A
Connector Interface Type	RG213, RG214, RG8, RG9, RG11, RG225, RG393
Attachment Method (Shield/Contact)	Clamp/Solder
Body Style	Right Angle

Electrical Specifications

Frequency Range	DC to 11 GHz
Impedance	50 Ohms
Maximum VSWR	1.35:1
Maximum Operating Voltage	500 Volts

Mechanical Specifications

Temperature

Operating Range	-65 to +165 deg C
-----------------	-------------------

Size

Length	1.84 in [46.74 mm]
Width/Dia.	0.748 in [19.00 mm]
Height	1.182 in [30.02 mm]
Weight	0.165 lbs [74.84 g]

Connector

Type	TNC Male
Contact Material and Plating	Brass, Gold
Body Material and Plating	Brass, Nickel
Body Plating Specification	100µ in. minimum
Dielectric Type	Teflon

Compliance Certifications (visit www.Pasternack.com for current document)

RoHS Compliant	
REACH Compliant	06/18/2012

Click the following link (or enter part number in "SEARCH" on website) to obtain additional part information including price, inventory and certifications: [TNC Male Right Angle Connector Clamp/Solder Attachment for RG213, RG214, RG8, RG9, RG11, RG225, RG393 PE4146](#)



TNC Male Right Angle Connector Clamp/Solder Attachment for RG213, RG214, RG8, RG9, RG11, RG225, RG393

TECHNICAL DATA SHEET

PE4146

Plotted and Other Data

Notes:

- Values at +25 °C, sea level

TNC Male Right Angle Connector Clamp/Solder Attachment for RG213, RG214, RG8, RG9, RG11, RG225, RG393 from Pasternack Enterprises has same day shipment for domestic and International orders. Our RF, microwave and millimeter wave products maintain a 99% availability and are part of the broadest selection in the industry.

Click the following link (or enter part number in "SEARCH" on website) to obtain additional part information including price, inventory and certifications: [TNC Male Right Angle Connector Clamp/Solder Attachment for RG213, RG214, RG8, RG9, RG11, RG225, RG393 PE4146](http://www.pasternack.com/tnc-male-standard-rg213-rg214-rg8-rg9-rg11-rg225-rg393-connector-pe4146-p.aspx)

URL: <http://www.pasternack.com/tnc-male-standard-rg213-rg214-rg8-rg9-rg11-rg225-rg393-connector-pe4146-p.aspx>

The information contained in this document is accurate to the best of our knowledge and representative of the part described herein. It may be necessary to make modifications to the part and/or the documentation of the part, in order to implement improvements. Pasternack reserves the right to make such changes as required. Unless otherwise stated, all specifications are nominal. Pasternack does not make any representation or warranty regarding the suitability of the part described herein for any particular purpose, and Pasternack does not assume any liability arising out of the use of any part or documentation.

PE4146 CAD Drawing

TNC Male Right Angle Connector Clamp/Solder Attachment for
RG213, RG214, RG8, RG9, RG11, RG225, RG393

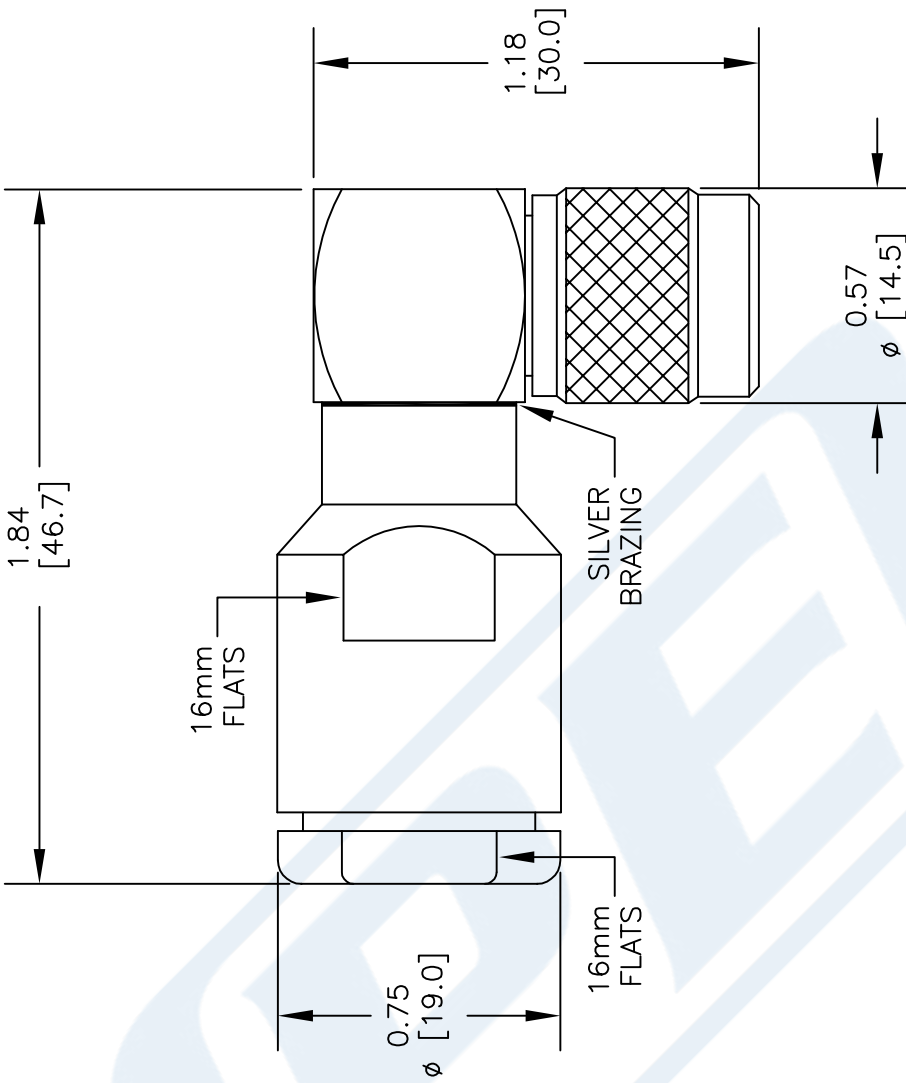

ASSEMBLY PROCEDURES

1. SLIDE CLAMP NUT (1), WASHER (2) & GASKET (3) OVER CABLE. STRIP CABLE AS SHOWN. DO NOT NICK BRAID WHILE CUTTING JACKET. TAPER END OF BRAID TO PERMIT ASSEMBLY OF BRAID CLAMP (4) SLIDE BRAID CLAMP (4) OVER BRAID & SEAT AGAINST CABLE.
2. FORM BRAID OVER CLAMP (4). TRIM BRAID BACK TO SHOULDER. CUT DIELECTRIC TO DIMENSION SHOWN. DO NOT NICK CENTER CONDUCTOR. SOLDER CONTACT TO CENTER CONDUCTOR. REMOVE EXCESS SOLDER. DO NOT OVER HEAT DIELECTRIC. INSERT CABLE ASSEMBLY INTO BODY & TIGHTEN.

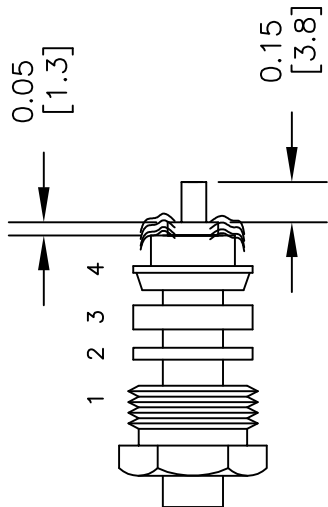
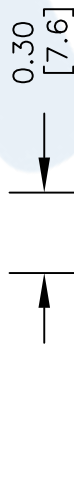

NOTES:
1. UNLESS OTHERWISE SPECIFIED ALL DIMENSIONS ARE NOMINAL.
2. ALL SPECIFICATIONS ARE SUBJECT TO CHANGE WITHOUT NOTICE AT ANY TIME.
3. DIMENSIONS ARE IN INCHES [mm].

DWG TITLE
PE4146

FSCM NO. 53919

150

SIZE A

SCALE N/A

CAD FILE 111414

PE PASTERNAK
THE ENGINEER'S RF SOURCE
Pasternack Enterprises, Inc.
P.O. Box 16759 | Irvine | CA | 92623

Phone: (949) 261-1920 | Fax: (949) 261-7451

Website: www.pasternack.com | E-Mail: sales@pasternack.com