

WSB5519F/5520F/5521F/5522F

Schottky Barrier Diode

Features

- Extremely Fast Switching Speed
- Standard products are Pb-free and Halogen-free



SOT-23

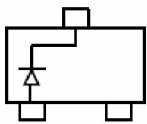

WSB5519F
MARKING:KL1

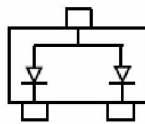

WSB5520F
MARKING:KL2

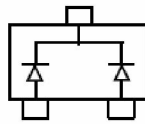

WSB5521F
MARKING:KL3

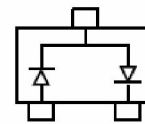

WSB5522F
MARKING:KL4

Order information

Device	Package	Shipping
WSB5519F-3/TR	SOT-23	3000/Tape&Reel
WSB5520F-3/TR	SOT-23	3000/Tape&Reel
WSB5521F-3/TR	SOT-23	3000/Tape&Reel
WSB5522F-3/TR	SOT-23	3000/Tape&Reel

WSB5519F/5520F/5521F/5522F
Absolute maximum ratings

Parameter	Symbol	Value	Unit
Peak Repetitive Peak Reverse Voltage	V_{RRM}	30	V
Working Peak Reverse Voltage	V_{RWM}	30	V
Blocking voltage (DC)	V_R	30	V
Forward Continuous Current	I_{FM}	0.2	A
Power Dissipation	P_D	200	mW
Thermal Resistance Junction to Ambient	$R_{\theta JA}$	500	$^{\circ}C/W$
Junction temperature	T_J	125	$^{\circ}C$
Storage temperature	T_{STG}	-55 ~ 150	$^{\circ}C$

Electronics characteristics ($T_A=25^{\circ}C$)

Parameter	Symbol	Condition	Min.	Typ.	Max.	Unit
Reverse breakdown voltage	V_{BR}	$I_R=100\mu A$	30			V
Forward voltage	V_{F1}	$I_F=0.1mA$			0.24	V
	V_{F2}	$I_F=1mA$			0.32	V
	V_{F3}	$I_F=10mA$			0.40	V
	V_{F4}	$I_F=30mA$			0.50	V
	V_{F5}	$I_F=100mA$			1	V
Reverse current	I_R	$V_R=25V$			2	μA
Diode capacitance	C_D	$V_R=1V, f=1MHz$			10	pF
Reverse recovery time	t_{rr}	$I_F=I_R=10mA$ $I_{rr}=0.1I_R, R_L=100\Omega$			5	ns

WSB5519F/5520F/5521F/5522F

Typical characteristics (Ta=25°C, unless otherwise noted)

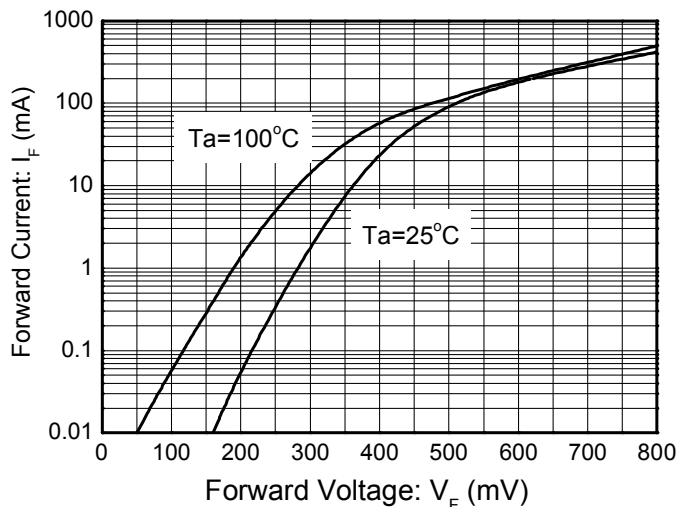

Forward voltage vs. Forward current

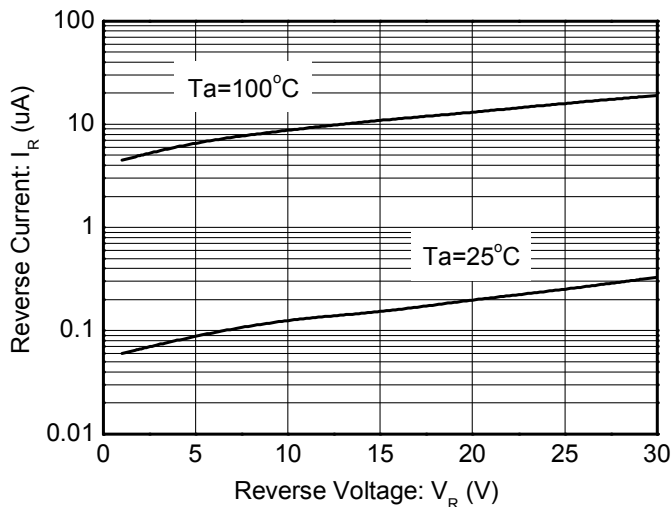

Reverse current vs. Reverse voltage

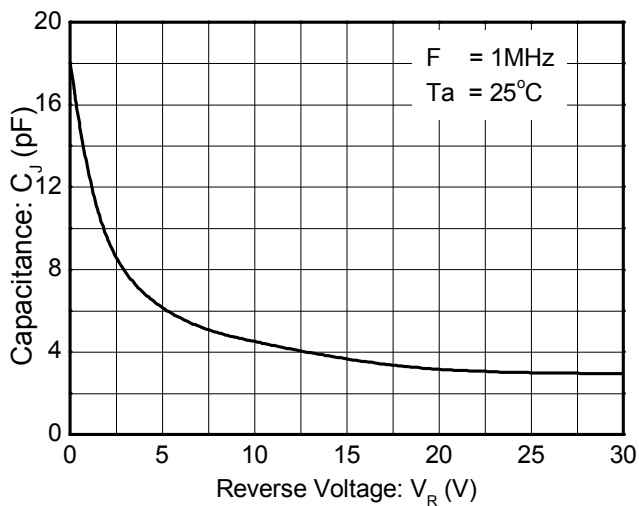

Junction capacitance vs. Reverse voltage

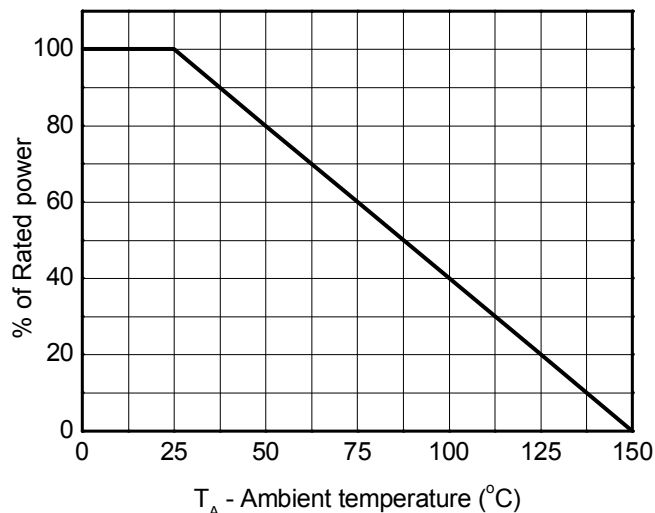

T_A - Ambient temperature ($^\circ\text{C}$)
Power Derating

WSB5519F/5520F/5521F/5522F

Package outline dimensions

SOT-23

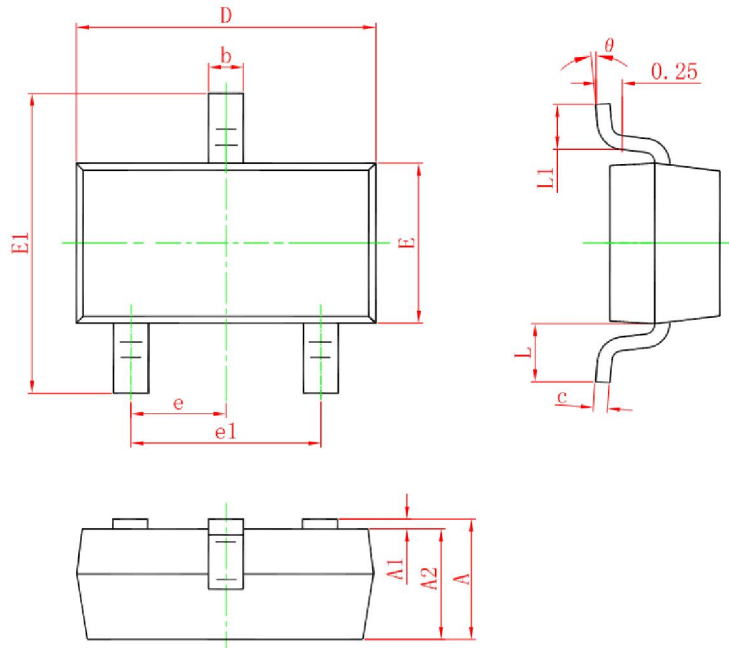

Symbol	Dimensions in millimeter		
	Min.	Typ.	Max.
A	0.900	1.025	1.150
A1	0.000	0.500	0.100
A2	0.900	0.975	1.050
b	0.300	0.400	0.500
c	0.080	0.115	0.150
D	2.800	2.900	3.000
E	1.200	1.300	1.400
E1	2.250	2.400	2.550
e	0.950TYP		
e1	1.800	1.900	2.000
L	0.500REF		
L1	0.300	0.400	0.500
θ	0°	4°	8°

Recommend PCB Layout (Unit: mm)

