

Features and Benefits

- **CMOS Technology**
- **Magnetic Type: Uni-polar**
- **Wide Operating Voltage Range:**
Supply Voltage 3.5~24V
- **Specified Operating Temperature Range:**
From -40°C~125°C
- **High Magnetic Sensitivity**
Bop=65Gauss, Brp=45Gauss (typical)
- **Lower Power Consumption**
Supply Current <3mA (typical)
- **Lead Free Package**
Flat TO-92, SOT-23, SOT-89B
- **High ESD Rating**
- **Open Drain Output**
- **RoHS Compliant**
2011/65/EU

Applications

- Automotive, Home appliances, Industrial
- Speed Detection
- Position Detection
- Magnetic Encoder
- Solid-State Switch
- Proximity Switch
- Water Flow Sensor

Family Members

Part number	Description
MT1102A	Flat TO-92 package, bulk packaging (1000pcs/bag)
MT1102A-T	Flat TO-92 package, Radial lead, bulk packaging (1000pcs/bag)
MT1102AT	SOT-23 package, tape and reel packaging (3000pcs/bag)
MT1102BT	SOT-89B package, tape and reel packaging (1000pcs/bag)
MT1102ET	SOT-23(thin outline) package, tape and reel packaging (3000pcs/bag)

General Description

The MT1102 family, produced with CMOS technology, The Hall IC internally includes an on-chip Hall voltage generator, a voltage regulator for operation with supply voltages of 3.5 to 24V, temperature compensation circuitry, small-signal amplifier, Hall sensor with dynamic offset cancellation system, Schmitt trigger and an open-drain output.

They are designed to respond to a single pole: North (AT) or South (A, BT and ET). While the magnetic flux density(B) is larger than operate point (Bop), the output will be turned on(Low), while the magnetic flux density(B) is lower than release point (Brp), then turn off (High).

The MT1102 family provides a variety of packages to customers: SOT-23/SOT-89B for surface mount and TO-92 flat for through-hole mount. All packages are RoHS compliant.

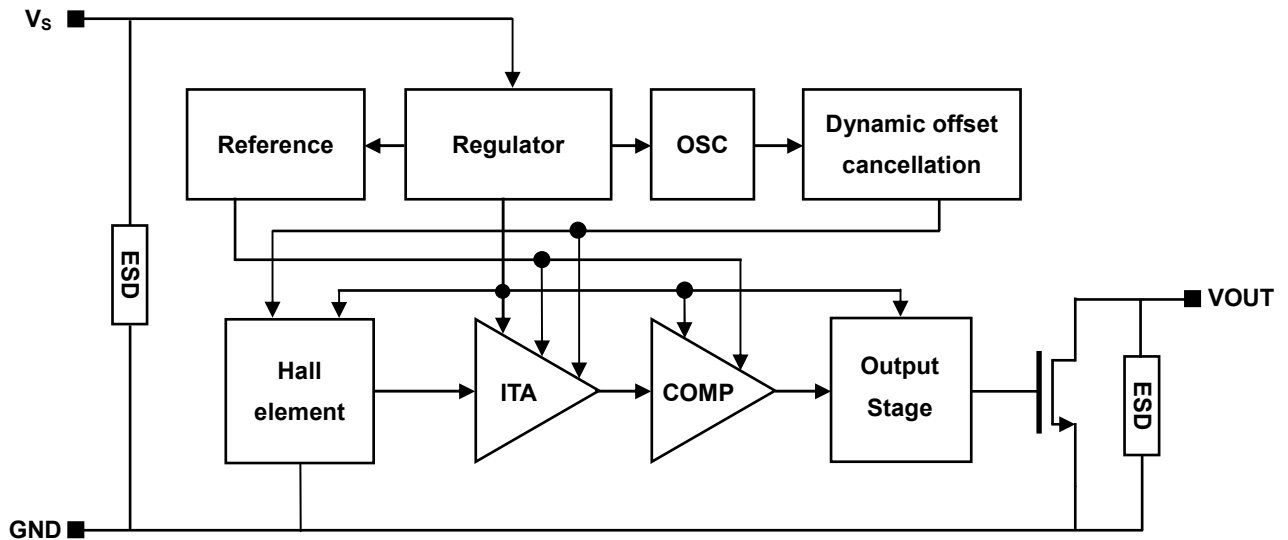

Functional Block Diagram

Function Description

Definition of Magnetic Parameters

- BOP: Operating Point
Magnetic flux density applied on the branded side of the package which turns the output driver ON ($V_{OUT} = \text{Low}$)
- BRP: Release Point
Magnetic flux density applied on the branded side of the package which turns the output driver OFF ($V_{OUT} = \text{high}$)
- BHYST: Hysteresis Window
BOP-BRP

Definition of Switching Function

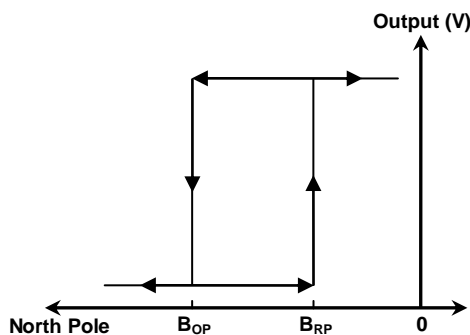

Switching Behavior of AT

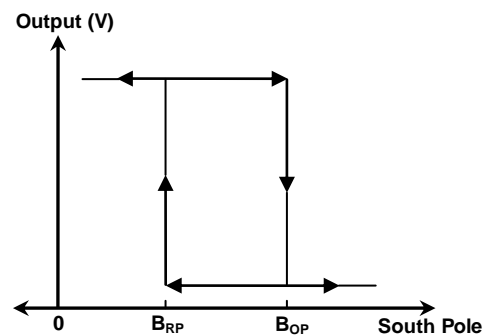

Switching Behavior of A, BT and ET

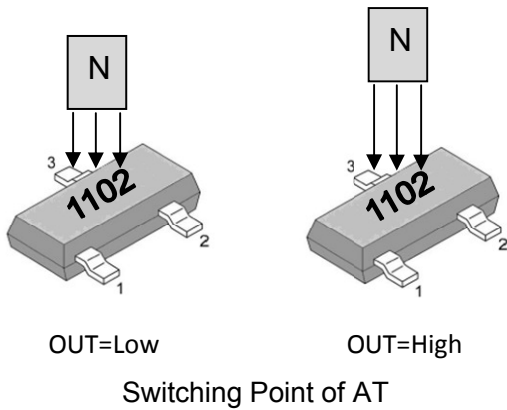

Motion ↑

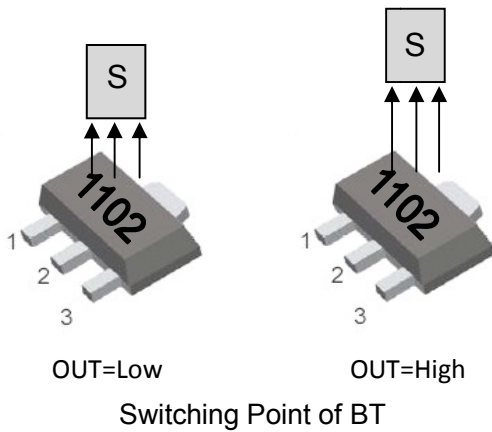
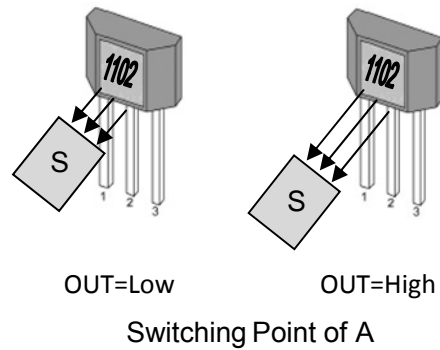

Motion ↑

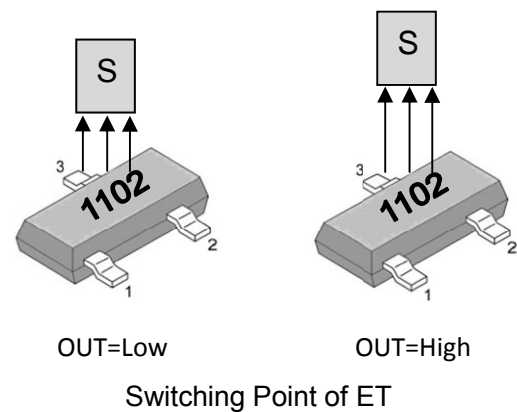

Note: ← ← ← Direction of magnetic flux

Pin Description

MT1102AT

Name	Number	Description
Vs	1	Power
GND	3	Ground
Output	2	Open-Drain output

MT1102A (MT1102A-T)

Name	Number	Description
Vs	1	Power
GND	2	Ground
Output	3	Open-Drain output

MT1102ET

Name	Number	Description
Vs	1	Power
GND	3	Ground
Output	2	Open-Drain output

MT1102BT

Name	Number	Description
Vs	1	Power
GND	2	Ground
Output	3	Open-Drain output

Electrical and Magnetic Characteristics

Absolute Maximum Ratings

Absolute maximum ratings are limiting values to be applied individually, and beyond which the serviceability of the circuit may be impaired. Functional operability is not necessarily implied. Exposure to absolute maximum rating conditions for an extended period of time may affect device reliability.

Absolute maximum ratings: all voltages listed are referenced to GND.

Symbol	Parameters	Min	Max	Units
V _S	Supply Voltage	-	28	V
V _{RCC}	Reverse Battery Voltage	-	-0.5	V
V _{OUT}	Output Voltage	-	28	V
I _{OUT}	Continuous output current	-	50	mA
T _A	Operating Ambient Temperature	-40	125	°C
T _S	Storage temperature	-50	150	°C
T _J	Junction temperature	-	150	°C
B	Magnetic flux	No Limit		Gauss

MT1102 Series Specifications

at T_A = -40°C to 125°C, V_S = 3.5V to 24V (unless otherwise specified)

Symbol	Parameter	Test Condition	Min	Typ	Max	Units
V _S	Supply Voltage	Operating	3.5	-	24	V
I _S	Supply Current	B < B _{RP}	1	2.0	5	mA
V _{DSON}	Output Saturation Voltage	I _{OUT} =20mA, B > B _{OP}	-	-	0.4	V
I _{OFF}	Output Leakage Current	B < B _{RP} , V _{OUT} =24V	-	-	1	uA
T _R	Output Rise Time	R _L =1KOhm, C _L =20pF	-	-	1.0	uS
T _F	Output Fall Time	R _L =1KOhm, C _L =20pF	-	-	1.0	uS
F _{SW}	Maximum Switching Frequency		-	-	10	KHz
R _{TH}	SOT-23 Package Thermal Resistance		-	301	-	°C/W
	TO-92 Package Thermal Resistance		-	230	-	°C/W
	SOT-89B Package Thermal Resistance		-	230	-	°C/W
B _{OP}	Magnetic Operating Point		50	65	80	Gauss
B _{RP}	Magnetic Release Point		30	45	60	Gauss
B _{HYST}	Hysteresis Window	B _{OP} -B _{RP}	10	20	30	Gauss
ESD	Electro-Static Discharge	HBM	-	4	-	KV

Typical Application Circuit

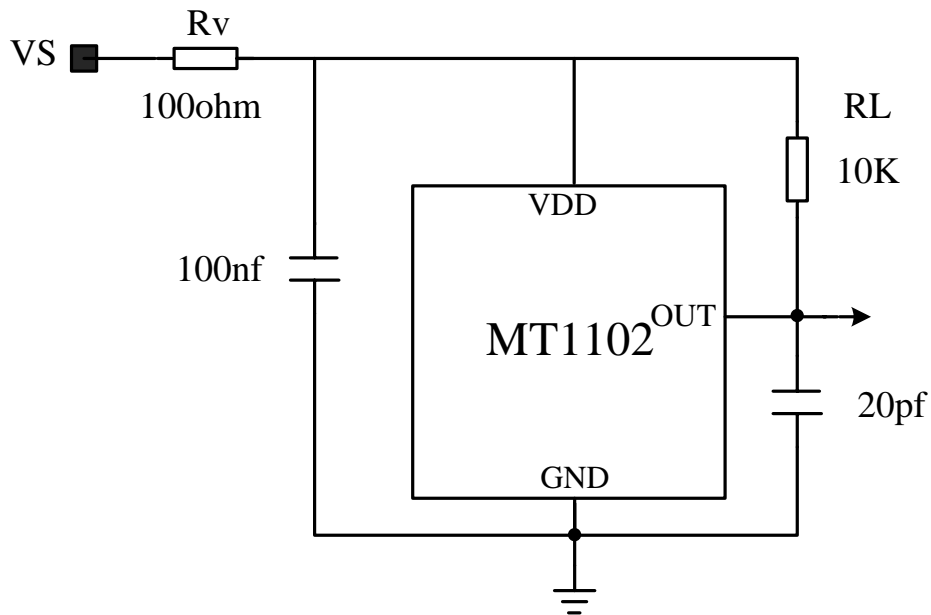

Typical Output Waveform (The TO-92 package as an example)

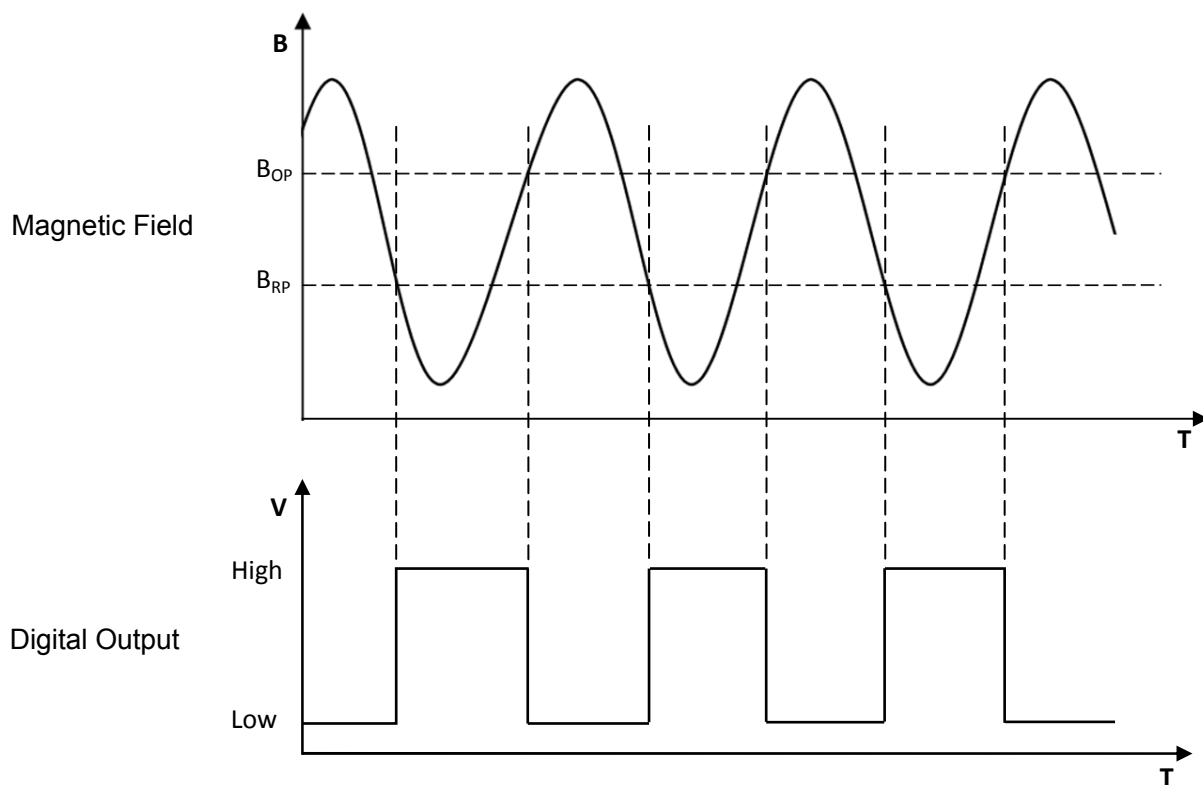

PACKAGE DESIGNATOR (MT1102A) TO-92 Flat

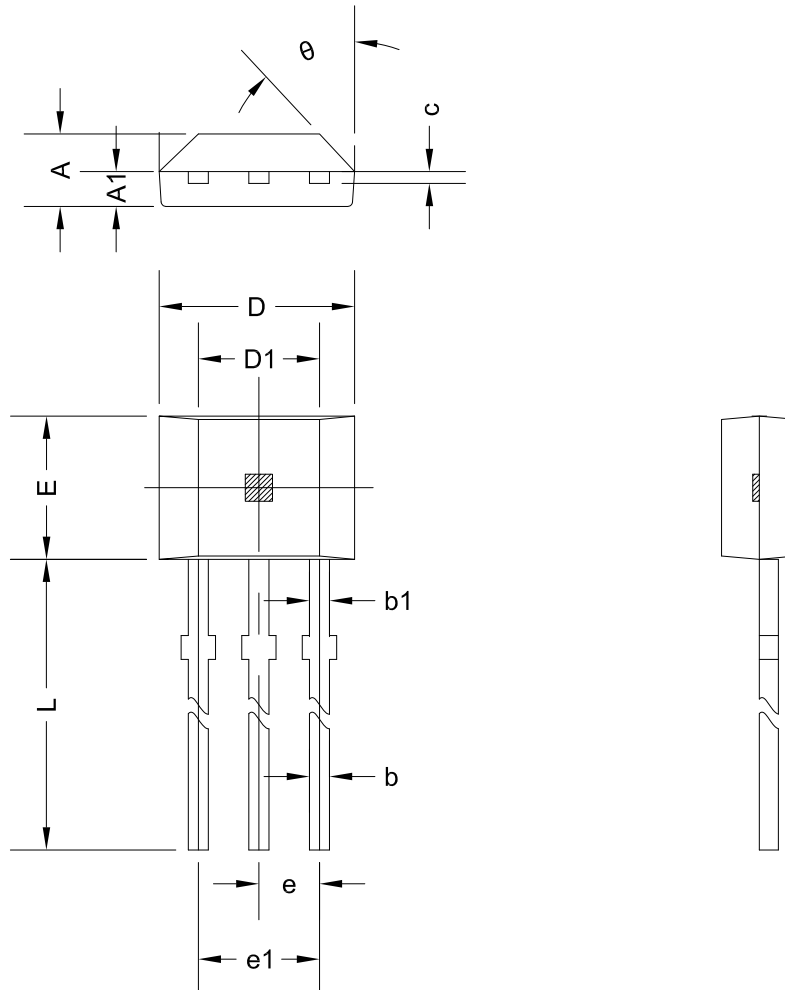

Symbol	Dimensions in Millimeters		Dimensions in Inches	
	Min	Max	Min	Max
A	1.420	1.620	0.056	0.064
A1	0.660	0.860	0.026	0.034
b	0.350	0.480	0.014	0.019
b1	0.400	0.550	0.016	0.022
c	0.360	0.510	0.014	0.020
D	3.900	4.200	0.154	0.165
D1	2.970	3.270	0.117	0.129
E	2.870	3.124	0.113	0.123
e	1.270 TYP.		0.050 TYP.	
e1	2.440	2.640	0.096	0.104
L	13.600	15.500	0.535	0.610
θ	45° TYP.		45° TYP.	

PACKAGE DESIGNATOR (MT1102A-T) Flat TO-92 Radial lead

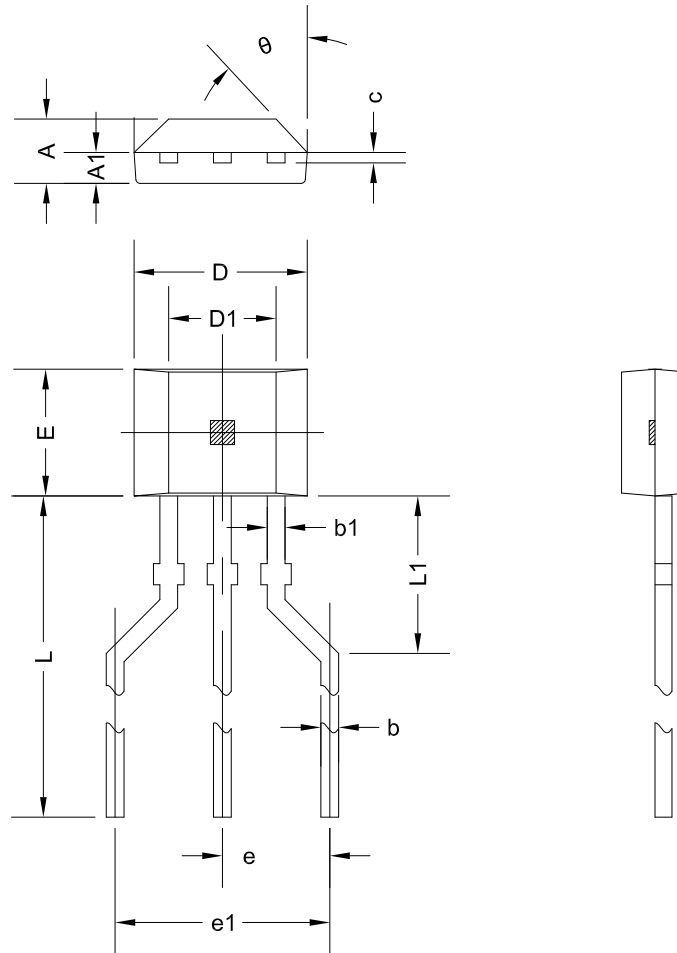

Symbol	Dimensions in Millimeters		Dimensions in Inches	
	Min	Max	Min	Max
A	1.420	1.620	0.056	0.064
A1	0.660	0.860	0.026	0.034
b	0.350	0.480	0.014	0.019
b1	0.400	0.550	0.016	0.022
c	0.360	0.510	0.014	0.020
D	3.900	4.200	0.154	0.165
D1	2.970	3.270	0.117	0.129
E	2.870	3.124	0.113	0.123
e	2.500 TYP.		0.100 TYP.	
e1	5.000 TYP.		0.200 TYP.	
L	14.300 REF.		0.563 REF.	
L1	3.300 REF.		0.130 REF.	
θ	45° TYP.		45° TYP.	

PACKAGE DESIGNATOR (MT1102AT) SOT-23-3L

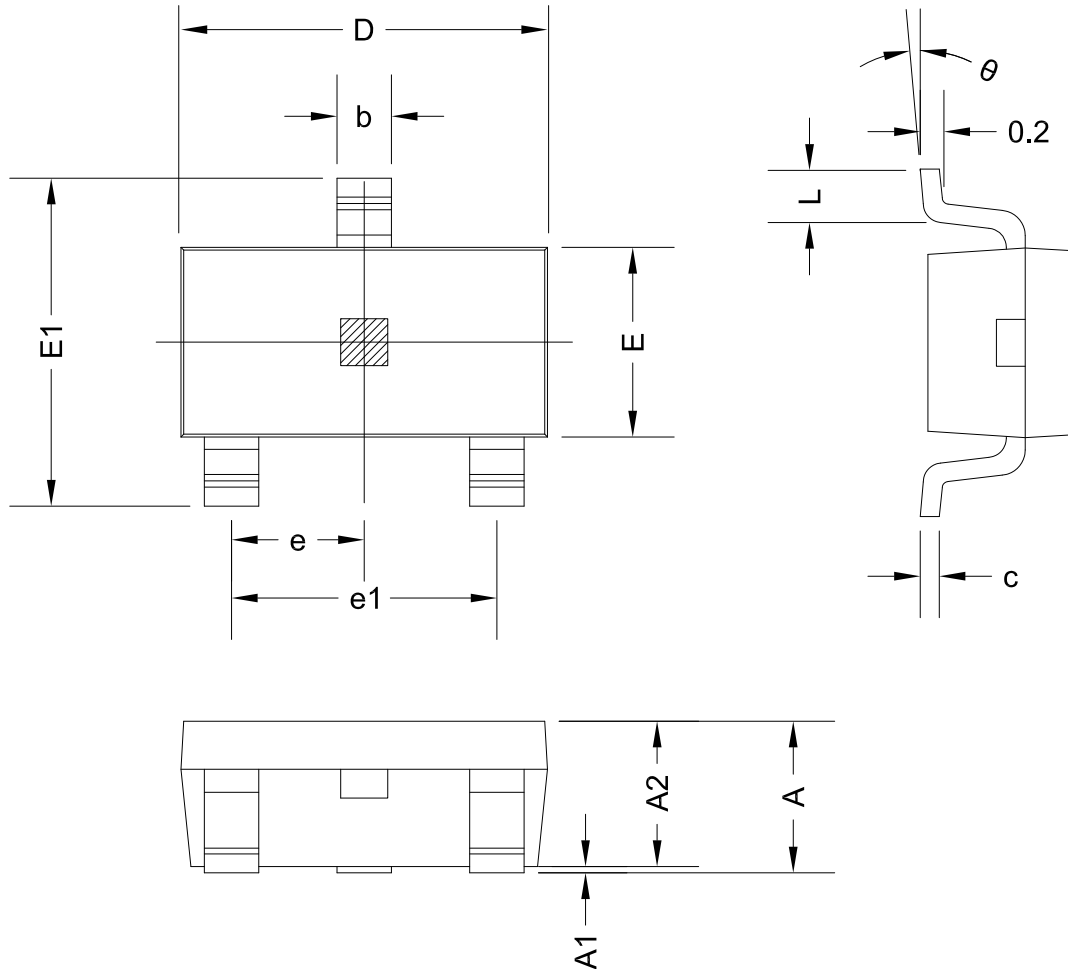

Symbol	Dimensions in Millimeters		Dimensions in Inches	
	Min	Max	Min	Max
A	1.050	1.250	0.041	0.049
A1	0.000	0.100	0.000	0.004
A2	1.050	1.150	0.041	0.045
b	0.300	0.500	0.012	0.020
c	0.100	0.200	0.004	0.008
D	2.820	3.020	0.111	0.119
E	1.500	1.700	0.059	0.067
E1	2.650	2.950	0.104	0.116
e	0.950 TYP.		0.037 TYP.	
e1	1.800	2.000	0.071	0.079
L	0.300	0.600	0.012	0.024
θ	0°	8°	0°	8°

PACKAGE DESIGNATOR (MT1102BT) SOT-89B

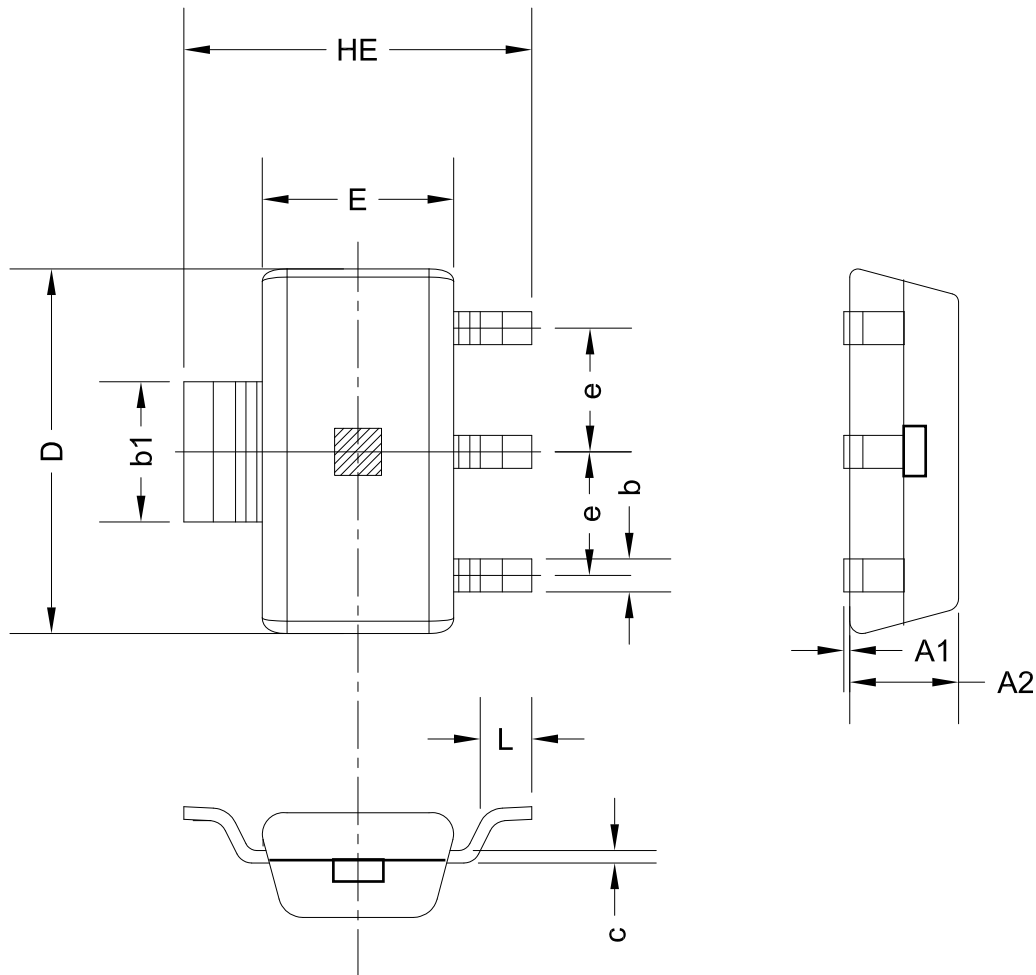

Symbol	Dimensions in Millimeters		Dimensions in Inches	
	Min	Max	Min	Max
A1	0.000	0.100	0.000	0.004
A2	1.220	1.420	0.048	0.056
b	0.300	0.500	0.012	0.020
b1	1.600	1.800	0.063	0.070
D	4.400	4.600	0.173	0.181
c	1.152 REF.		0.045 REF.	
E	2.400	2.600	0.094	0.102
HE	4.000	4.400	0.157	0.173
e	1.500 TYP.		0.060 TYP.	
L	0.350	0.550	0.014	0.022

PACKAGE DESIGNATOR

(MT1102ET) SOT-23

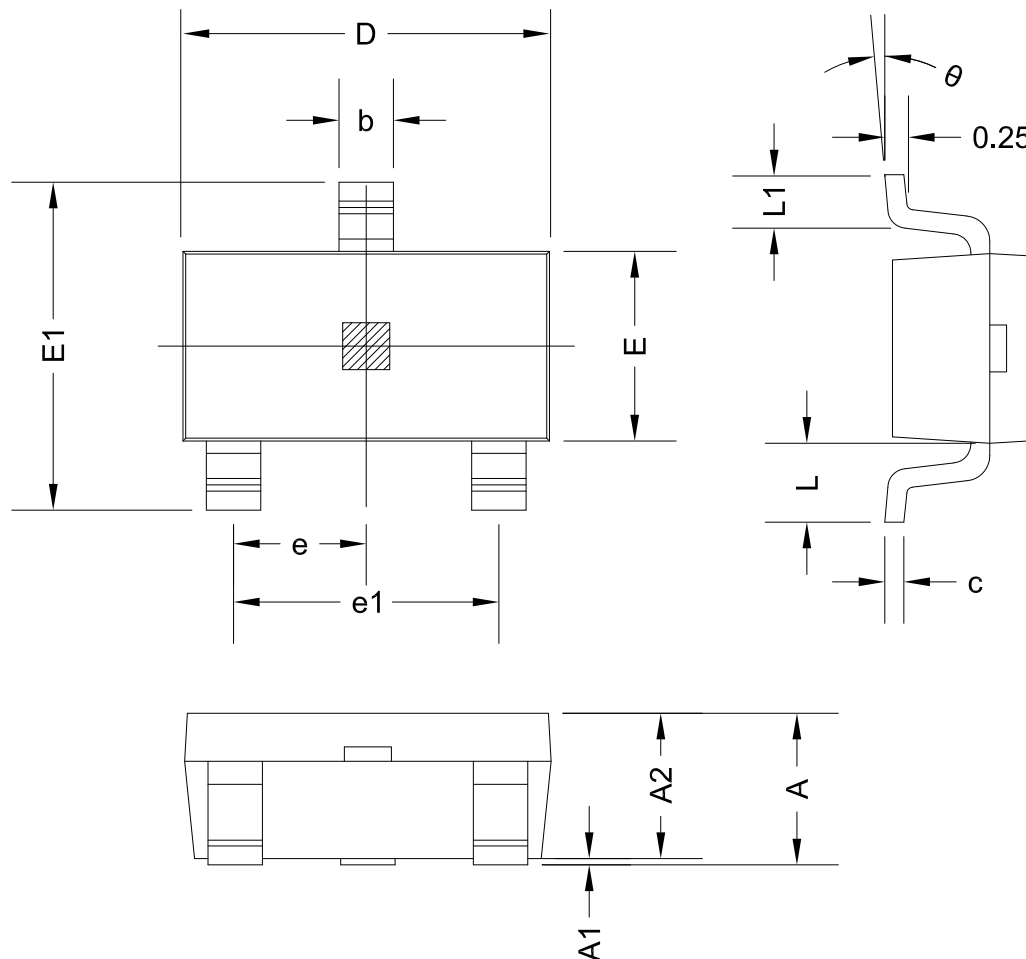

Symbol	Dimensions in Millimeters		Dimensions in Inches	
	Min	Max	Min	Max
A	0.900	1.150	0.035	0.045
A1	0.000	0.100	0.000	0.004
A2	0.900	1.050	0.035	0.041
b	0.300	0.500	0.012	0.020
c	0.080	0.150	0.003	0.006
D	2.800	3.000	0.110	0.118
E	1.200	1.400	0.047	0.055
E1	2.250	2.550	0.089	0.100
e	0.950 TYP.		0.037 TYP.	
e1	1.800	2.000	0.071	0.079
L	0.550 REF.		0.022 REF.	
L1	0.300	0.500	0.012	0.020
θ	0°	8°	0°	8°