



DATA SHEET

MMBD914WS

SURFACE MOUNT SWITCHING DIODES

VOLTAGE	100Volts	POWER	200mW
----------------	-----------------	--------------	--------------

FEATURES

- Very fast reverse recovery ($T_{rr} < 2.0$ ns typical)
- Low capacitance (2pF @ 0V typical)
- Surface mount package ideally suited for automatic insertion
- In compliance with EU RoHS 2002/95/EC directives

MECHANICAL DATA

- Case: SOD-323 plastic
- Terminals: Solderable per MIL-STD-750, Method 2026
- Approx weight: 4.1mg
- Marking: T1

ABSOLUTE RATINGS

PARAMETER	SYMBOL	VALUE	UNIT
Maximum Reverse Voltage	V_R	100	V
Peak Reverse Voltage	V_{RRM}	100	V
Continuous Forward Current	I_F	0.2	A
Non-repetitive Peak Forward Surge Current at $t=1.0$ us	I_{FSM}	4.0	A

THERMAL CHARACTERISTICS

PARAMETER	SYMBOL	VALUE	UNIT
Power Dissipation ⁽¹⁾	P_{TOT}	200	mW
Thermal Resistance , Junction to Ambient ⁽¹⁾	R_{JA}	625	/W
Junction Temperature	T_J	-55 to 150	
Storage Temperature	T_{STG}	-55 to 150	

Note 1. FR-4 Board = 70 x 60 x 1mm.

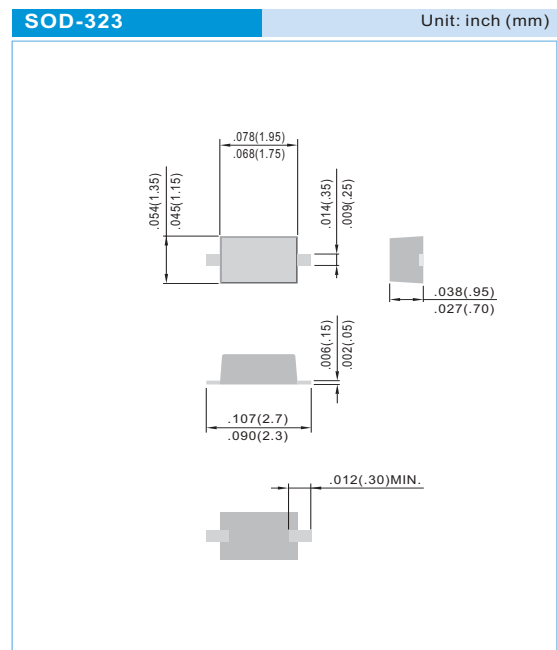



ELECTRICAL CHARACTERISTICS (T_J=25°C, unless otherwise noted)

PARAMETER	SYMBOL	TEST CONDITION	MIN.	TYP.	MAX.	UNIT
Reverse Breakdown Voltage	V _(BR)	I _R =100uA	100	-	-	V
Reverse Current	I _R	V _R =20V V _R =75V	-	-	0.025 5.0	uA
Forward Voltage	V _F	I _F =10mA	-	-	1.0	V
Total Capacitance	C _T	V _R =0V, f=1MHz	-	-	4.0	pF
Reverse Recovery Time (Figure 1)	t _{rr}	I _F =I _R =10mA, R _L =100Ω	-	-	4.0	ns

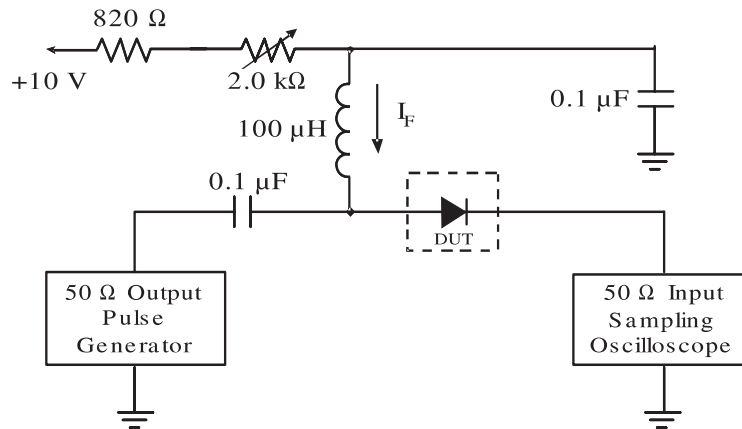

- Notes: 1. A 2.0kΩ variable resistor adjusted for a forward current (I_F) to 10mA
 2. Input pulse is adjusted to I_{R(peak)} is equal to 10mA

Figure 1. REVERSE RECOVERY TIME EQUIVALENT TEST CIRCUIT



ELECTRICAL CHARACTERISTIC CURVES

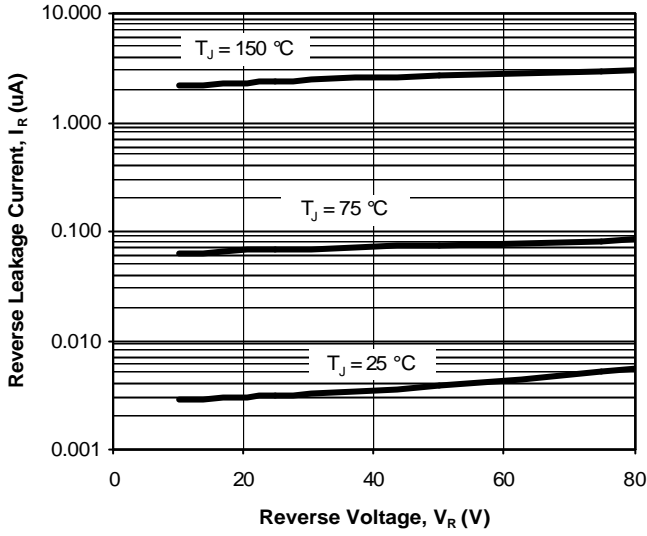

Fig. 2. Reverse Current vs. Reverse Voltage

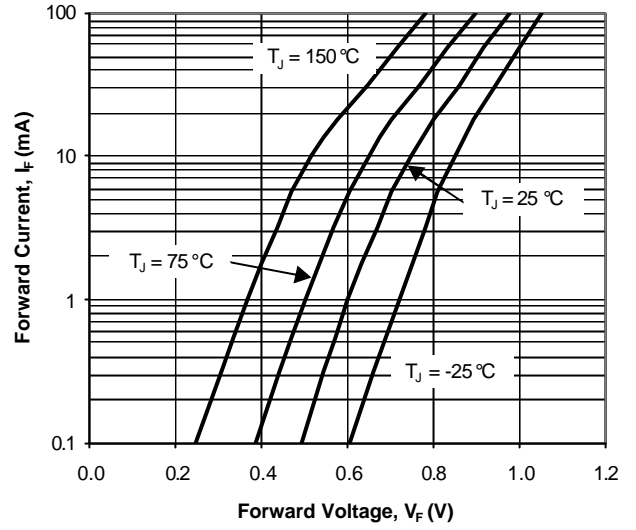

Fig. 3. Forward Current vs. Forward Voltage

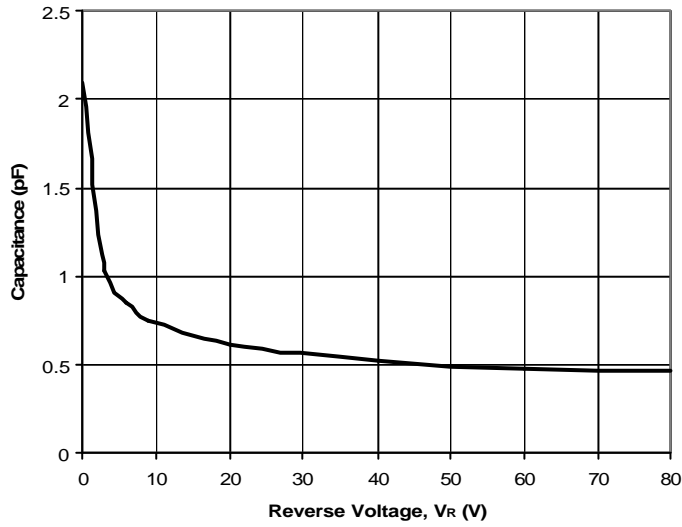
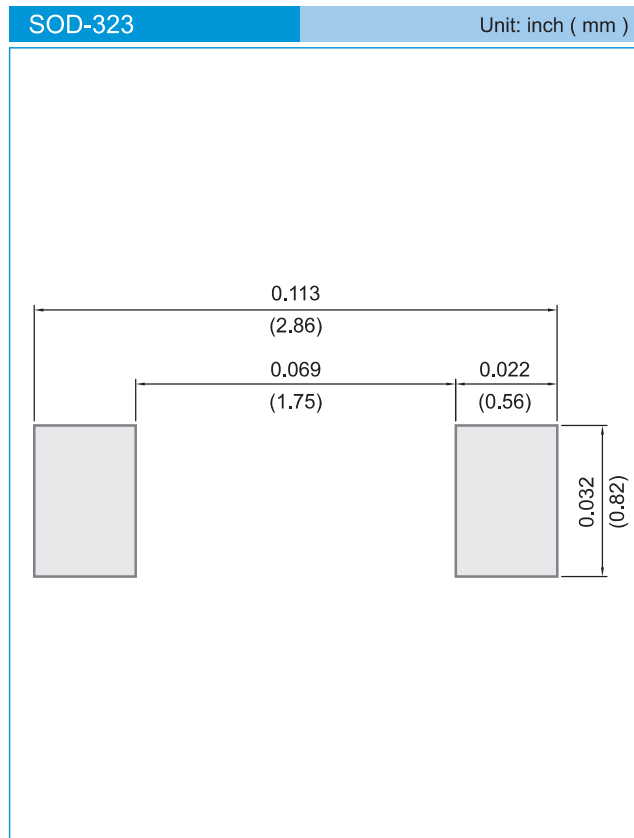

Fig. 4. Capacitance vs. Reverse Voltage



MOUNTING PAD LAYOUT



ORDER INFORMATION

- Packing information
 - T/R - 12K per 13" plastic Reel
 - T/R - 5K per 7" plastic Reel

LEGAL STATEMENT

Copyright PanJit International, Inc 2009

The information presented in this document is believed to be accurate and reliable. The specifications and information herein are subject to change without notice. Pan Jit makes no warranty, representation or guarantee regarding the suitability of its products for any particular purpose. Pan Jit products are not authorized for use in life support devices or systems. Pan Jit does not convey any license under its patent rights or rights of others.