

20 STERN AVE.
 SPRINGFIELD, NEW JERSEY 07081
 U.S.A.

TELEPHONE: (973) 376-2922
 (212) 227-6005
 FAX: (973) 376-8960

IRF630,631 D84DN2,M2
9.0 AMPERES 200, 150 VOLTS $R_{DS(ON)} = 0.4 \Omega$

POWER-MOS FET

FIELD EFFECT POWER TRANSISTOR

Features

- Polysilicon gate — Improved stability and reliability
- No secondary breakdown — Excellent ruggedness
- Ultra-fast switching — Independent of temperature
- Voltage controlled — High transconductance
- Low input capacitance — Reduced drive requirement
- Excellent thermal stability — Ease of paralleling

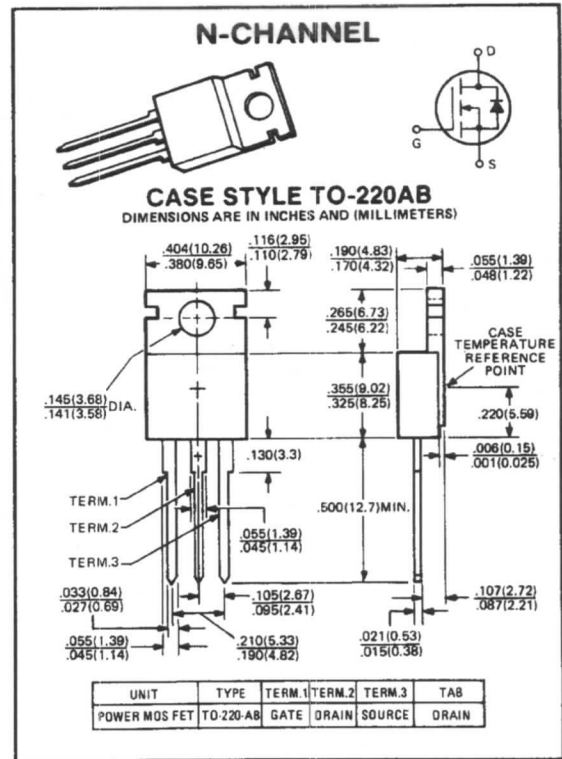

maximum ratings ($T_C = 25^\circ C$) (unless otherwise specified)

RATING	SYMBOL	IRF630/D84DN2	IRF631/D84DM2	UNITS
Drain-Source Voltage	V_{DSS}	200	150	Volts
Drain-Gate Voltage, $R_{GS} = 1M\Omega$	V_{DGR}	200	150	Volts
Continuous Drain Current @ $T_C = 25^\circ C$ @ $T_C = 100^\circ C$	I_D	9.0 6.0	9.0 6.0	A A
Pulsed Drain Current ⁽¹⁾	I_{DM}	36	36	A
Gate-Source Voltage	V_{GS}	± 20	± 20	Volts
Total Power Dissipation @ $T_C = 25^\circ C$ Derate Above $25^\circ C$	P_D	75 0.6	75 0.6	Watts W/ $^\circ C$
Operating and Storage Junction Temperature Range	T_J, T_{STG}	-55 to 150	-55 to 150	$^\circ C$

thermal characteristics

Thermal Resistance, Junction to Case	$R_{\theta JC}$	1.67	1.67	$^\circ C/W$
Thermal Resistance, Junction to Ambient	$R_{\theta JA}$	80	80	$^\circ C/W$
Maximum Lead Temperature for Soldering Purposes: 1/8" from Case for 5 Seconds	T_L	260	260	$^\circ C$

(1) Repetitive Rating: Pulse width limited by max. junction temperature.



NJ Semi-Conductors reserves the right to change test conditions, parameter limits and package dimensions without notice. Information furnished by NJ Semi-Conductors is believed to be both accurate and reliable at the time of going to press. However, NJ Semi-Conductors assumes no responsibility for any errors or omissions discovered in its use. NJ Semi-Conductors encourages customers to verify that datasheets are current before placing orders.

Quality Semi-Conductors

electrical characteristics ($T_C = 25^\circ\text{C}$) (unless otherwise specified)

CHARACTERISTIC	SYMBOL	MIN	TYP	MAX	UNIT
----------------	--------	-----	-----	-----	------

off characteristics

Drain-Source Breakdown Voltage ($V_{GS} = 0V, I_D = 250 \mu A$)	IRF630/D84DN2 IRF631/D84DM2	BV _{DSS}	200 150	— —	— —	Volts
Zero Gate Voltage Drain Current ($V_{DS} = \text{Max Rating}, V_{GS} = 0V, T_C = 25^\circ\text{C}$) ($V_{DS} = \text{Max Rating}, \times 0.8, V_{GS} = 0V, T_C = 125^\circ\text{C}$)		I_{DSS}	— —	— —	250 1000	μA
Gate-Source Leakage Current ($V_{GS} = \pm 20V$)		I_{GSS}	—	—	± 500	nA

on characteristics*

Gate Threshold Voltage ($V_{DS} = V_{GS}, I_D = 250 \mu A$)	$T_C = 25^\circ\text{C}$	$V_{GS(TH)}$	2.0	—	4.0	Volts
On-State Drain Current ($V_{GS} = 10V, V_{DS} = 10V$)		$I_{D(ON)}$	9.0	—	—	A
Static Drain-Source On-State Resistance ($V_{GS} = 10V, I_D = 5.0A$)		$R_{DS(ON)}$	—	0.34	0.4	Ohms
Forward Transconductance ($V_{DS} = 10V, I_D = 5.0A$)		g_{fs}	2.4	3.0	—	mhos

dynamic characteristics

Input Capacitance	$V_{GS} = 0V$	C_{iss}	—	650	800	pF
Output Capacitance	$V_{DS} = 25V$	C_{oss}	—	150	450	pF
Reverse Transfer Capacitance	$f = 1 \text{ MHz}$	C_{rss}	—	30	150	pF

switching characteristics*

Turn-on Delay Time	$V_{DS} = 90V$	$t_{d(on)}$	—	15	—	ns
Rise Time	$I_D = 5.0A, V_{GS} = 15V$	t_r	—	25	—	ns
Turn-off Delay Time	$R_{GEN} = 50\Omega, R_{GS} = 12.5\Omega$	$t_{d(off)}$	—	30	—	ns
Fall Time	$(R_{GS} \text{ (EQUIV.)} = 10\Omega)$	t_f	—	20	—	ns

source-drain diode ratings and characteristics*

Continuous Source Current		I_S	—	—	9.0	A
Pulsed Source Current		I_{SM}	—	—	36.0	A
Diode Forward Voltage ($T_C = 25^\circ\text{C}, V_{GS} = 0V, I_S = 9.0A$)		V_{SD}	—	1.0	2.0	Volts
Reverse Recovery Time ($I_S = 9.0A, di_S/dt = 100A/\mu\text{sec}, T_C = 125^\circ\text{C}$)		t_{rr} Q_{RR}	— —	300 2.5	— —	ns μC

*Pulse Test: Pulse width $\leq 300 \mu s$, duty cycle $\leq 2\%$

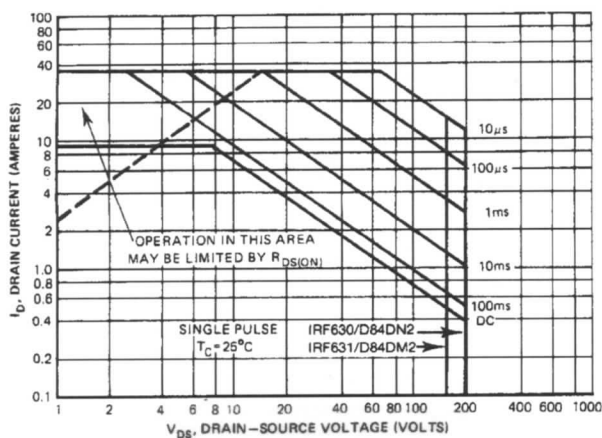

MAXIMUM SAFE OPERATING AREA

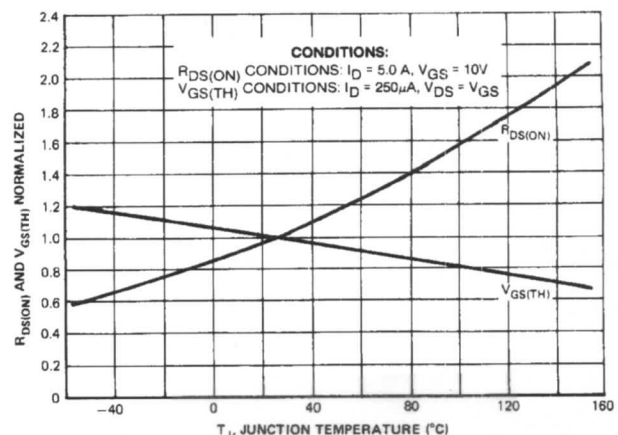

TYPICAL NORMALIZED $R_{DS(ON)}$ AND $V_{GS(TH)}$ VS. TEMP.