



UTT10NP06

Power MOSFET

DUAL ENHANCEMENT MODE (N-CHANNEL/ P-CHANNEL)

DESCRIPTION

The UTC **UTT10NP06** incorporates an N-channel MOSFET and a P-channel MOSFET, it uses UTC's advanced technology to provide customers a minimum on-state resistance, high switching speed, low gate charge and cost effectiveness.

The UTC **UTT10NP06** is universally applied in low voltage applications.

FEATURES

- * $R_{DS(on)} < 56m\Omega @ V_{GS}=10V, I_D=4A$
- $R_{DS(on)} < 64m\Omega @ V_{GS}=4.5V, I_D=2A$
- * $R_{DS(on)} < 68m\Omega @ V_{GS}= -10V, I_D= -3A$
- $R_{DS(on)} < 88m\Omega @ V_{GS}= -4.5V, I_D= -2A$
- * High switching speed

SYMBOL

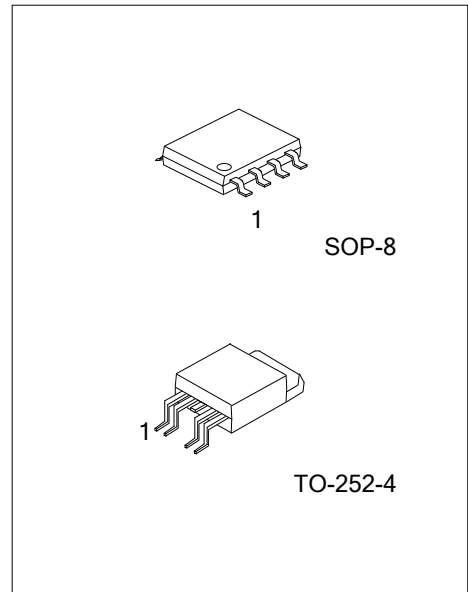
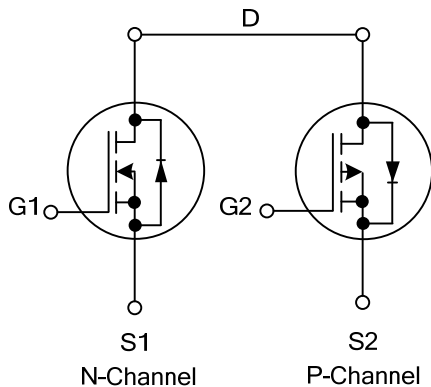

ORDERING INFORMATION

Ordering Number		Package	Pin Assignment								Packing
Lead Free	Halogen Free		1	2	3	4	5	6	7	8	
UTT10NP06L-S08-T	UTT10NP06G-S08-T	SOP-8	S1	G1	S2	G2	D	D	D	D	Tube
UTT10NP06L-S08-R	UTT10NP06G-S08-R	SOP-8	S1	G1	S2	G2	D	D	D	D	Tape Reel
UTT10NP06L-TN4-T	UTT10NP06G-TN4-T	TO-252-4	S1	G1	D	S2	G2	-	-	-	Tube
UTT10NP06L-TN4-R	UTT10NP06G-TN4-R	TO-252-4	S1	G1	D	S2	G2	-	-	-	Tape Reel

Note: Pin Assignment: G: Gate D: Drain S: Source

UTT10NP06L-S08-T (1)Packing Type (2)Package Type (3)Lead Free	(1) T: Tube, R: Tape Reel (2) S08: SOP-8, TN4: TO-252-4 (3) L: Lead Free, G: Halogen Free
--	---

■ PIN CONFIGURATION

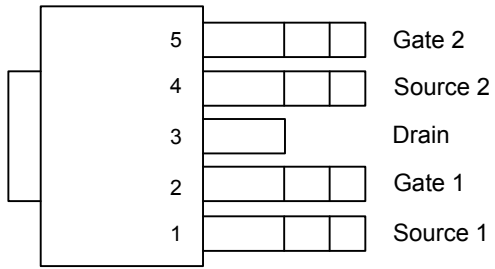

TO-252-4

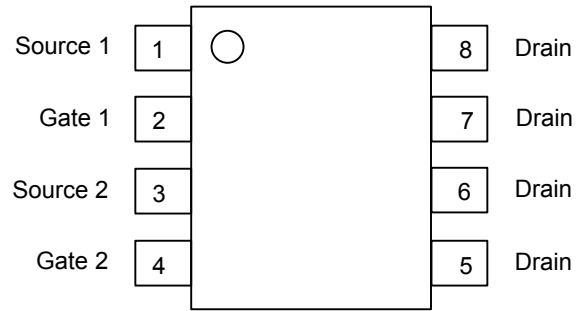

SOP-8

■ ABSOLUTE MAXIMUM RATINGS

PARAMETER		SYMBOL	RATINGS		UNIT
			N-CHANNEL	P-CHANNEL	
Drain-Source Voltage		V_{DSS}	60	-60	V
Gate-Source Voltage		V_{GSS}	± 20	± 20	V
Drain Current	Continuous $T_A=25^\circ\text{C}$	I_D	4.5	-3	A
	Pulsed (Note 1)	I_{DM}	20	-20	A
Power Dissipation	$T_A=25^\circ\text{C}$	P_D	2.0		W
Junction Temperature		T_J	-55~+150		$^\circ\text{C}$
Storage Temperature Range		T_{STG}	-55~+150		$^\circ\text{C}$

Note Absolute maximum ratings are those values beyond which the device could be permanently damaged.

: Absolute maximum ratings are stress ratings only and functional device operation is not implied.

■ THERMAL CHARACTERISTICS

PARAMETER	SYMBOL	RATINGS	UNIT
Junction to Ambient	θ_{JA}	62.5	$^\circ\text{C/W}$

■ ELECTRICAL CHARACTERISTICS ($T_J=25^\circ\text{C}$, unless otherwise specified)

N-Channel

PARAMETER		SYMBOL	TEST CONDITIONS	MIN	TYP	MAX	UNIT
OFF CHARACTERISTICS							
Drain-Source Breakdown Voltage		BV_{DSS}	$I_D=250\mu\text{A}, V_{GS}=0\text{V}$	60			V
Drain-Source Leakage Current		I_{DSS}	$V_{DS}=60\text{V}, V_{GS}=0\text{V}, T_J=25^\circ\text{C}$			1	μA
			$V_{DS}=48\text{V}, V_{GS}=0\text{V}, T_J=125^\circ\text{C}$			10	μA
Gate-Source Leakage Current	Forward	I_{GSS}	$V_{GS}=+20\text{V}$			+100	nA
	Reverse		$V_{GS}=-20\text{V}$			-100	nA
ON CHARACTERISTICS							
Gate Threshold Voltage		$V_{GS(TH)}$	$V_{DS}=V_{GS}, I_D=250\mu\text{A}$	1		3	V
Static Drain-Source On-State Resistance (Note 2)		$R_{DS(ON)}$	$V_{GS}=10\text{V}, I_D=4\text{A}$		36	56	m Ω
			$V_{GS}=4.5\text{V}, I_D=2\text{A}$		44	64	m Ω
DYNAMIC PARAMETERS							
Input Capacitance		C_{ISS}	$V_{GS}=0\text{V}, V_{DS}=25\text{V}, f=1.0\text{MHz}$		1100	1500	pF
Output Capacitance		C_{OSS}			80		pF
Reverse Transfer Capacitance		C_{RSS}			60		pF
SWITCHING PARAMETERS							
Total Gate Charge (Note 2)		Q_G	$V_{GS}=4.5\text{V}, V_{DS}=48\text{V}, I_D=4\text{A}$		120	150	nC
Gate to Source Charge		Q_{GS}			12		nC
Gate to Drain Charge		Q_{GD}			60		nC
Turn-ON Delay Time (Note 2)		$t_{D(ON)}$	$V_{DS}=30\text{V}, I_D=1\text{A}, R_G=3.3\Omega,$ $V_{GS}=10\text{V}, R_D=30\Omega$		33		ns
Rise Time		t_R			26		ns
Turn-OFF Delay Time		$t_{D(OFF)}$			140		ns
Fall-Time		t_F			64		ns
SOURCE- DRAIN DIODE RATINGS AND CHARACTERISTICS							
Drain-Source Diode Forward Voltage(Note 2)		V_{SD}	$I_S=1.7\text{A}, V_{GS}=0\text{V}$			1.2	V

■ ELECTRICAL CHARACTERISTICS(Cont.)

P-Channel

PARAMETER	SYMBOL	TEST CONDITIONS	MIN	TYP	MAX	UNIT	
OFF CHARACTERISTICS							
Drain-Source Breakdown Voltage	BV_{DSS}	$I_D=-250\mu A, V_{GS}=0V$	-60			V	
Drain-Source Leakage Current	I_{DSS}	$V_{DS}=-60V, V_{GS}=0V, T_J=25^\circ C$			-1	μA	
		$V_{DS}=-48V, V_{GS}=0V, T_J=125^\circ C$			-10	μA	
Gate-Source Leakage Current	Forward	I_{GSS}			+100	nA	
	Reverse				-100	nA	
ON CHARACTERISTICS							
Gate Threshold Voltage	$V_{GS(TH)}$	$V_{DS}=V_{GS}, I_D=-250\mu A$	-1		-3	V	
Static Drain-Source On-State Resistance (Note 2)	$R_{DS(ON)}$	$V_{GS}=-10V, I_D=-3A$		48	68	m Ω	
		$V_{GS}=-4.5V, I_D=-2A$		68	88	m Ω	
DYNAMIC PARAMETERS							
Input Capacitance	C_{ISS}	$V_{GS}=0V, V_{DS}=-25V, f=1.0MHz$		1900	2300	pF	
Output Capacitance	C_{OSS}			90		pF	
Reverse Transfer Capacitance	C_{RSS}			75		pF	
SWITCHING PARAMETERS							
Total Gate Charge (Note 2)	Q_G	$V_{GS}=-4.5V, V_{DS}=-48V, I_D=-3A$		200	230	nC	
Gate to Source Charge	Q_{GS}			30		nC	
Gate to Drain Charge	Q_{GD}			70		nC	
Turn-ON Delay Time (Note 2)	$t_{D(ON)}$	$V_{DS}=-30V, I_D=-1A, R_G=3.3\Omega$		48		ns	
Rise Time	t_R			42		ns	
Turn-OFF Delay Time	$t_{D(OFF)}$		$V_{GS}=-10V, R_D=30\Omega$		280		ns
Fall-Time	t_F				150		ns
SOURCE- DRAIN DIODE RATINGS AND CHARACTERISTICS							
Drain-Source Diode Forward Voltage(Note 2)	V_{SD}	$I_S=-1.7A, V_{GS}=0V$			-1.2	V	

- Notes: 1. Pulse width limited by maximum junction temperature
 2. Pulse width $\leq 300\mu s$, Duty cycle $\leq 2\%$

■ TEST CIRCUITS AND WAVEFORMS

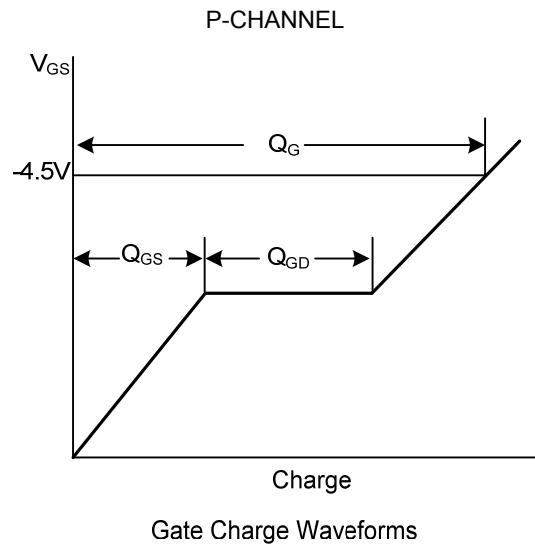
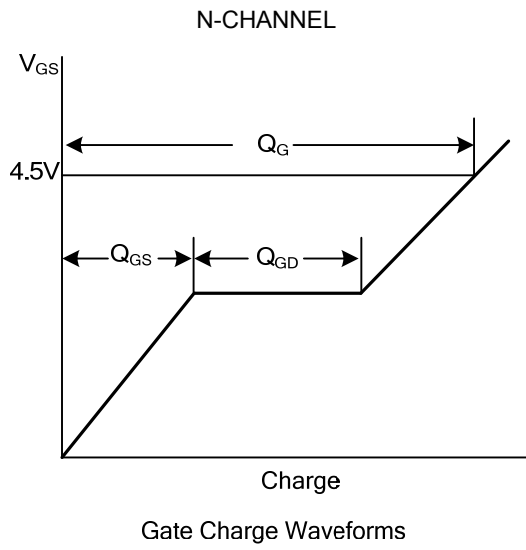

■ TYPICAL CHARACTERISTICS

N-CHANNEL

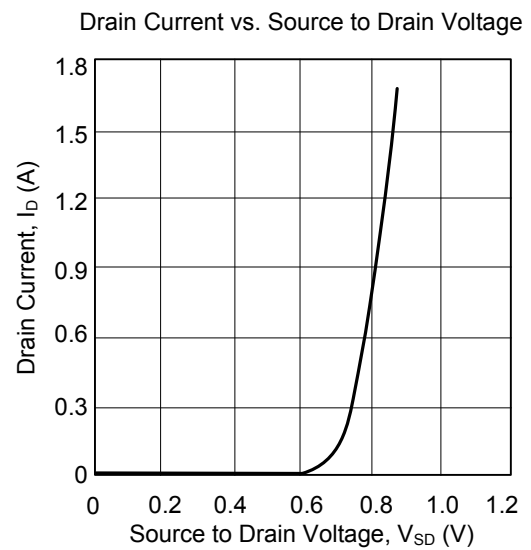
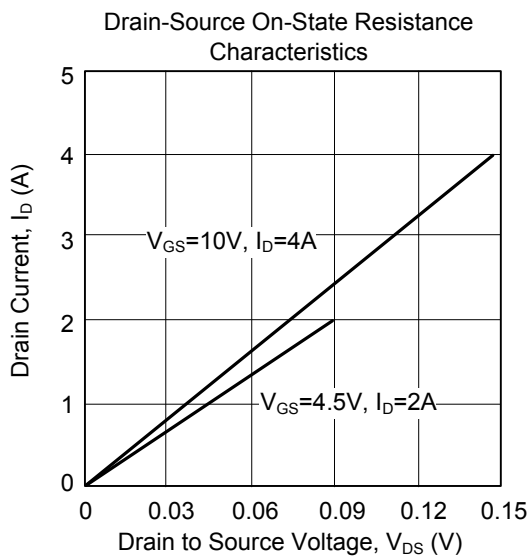
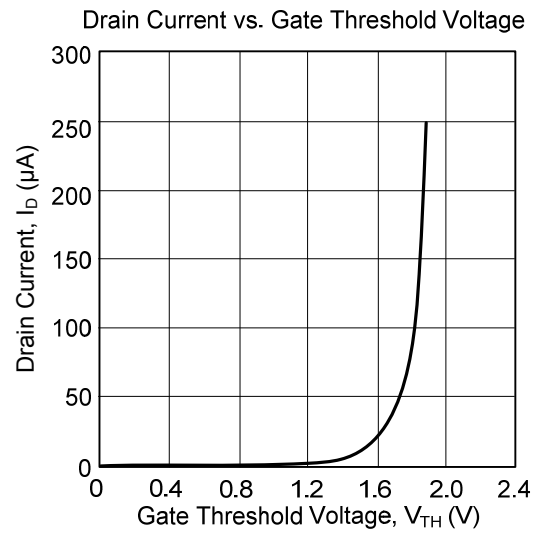
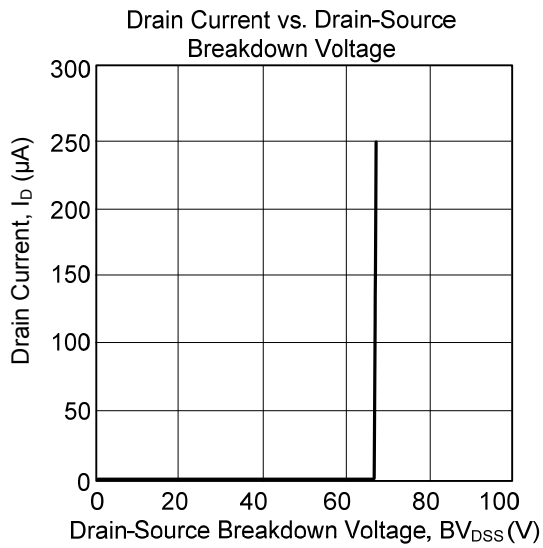

■ TYPICAL CHARACTERISTICS(Cont.)

P-CHANNEL

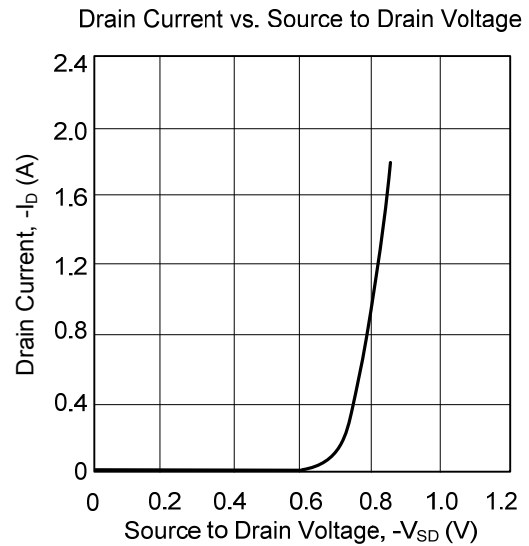
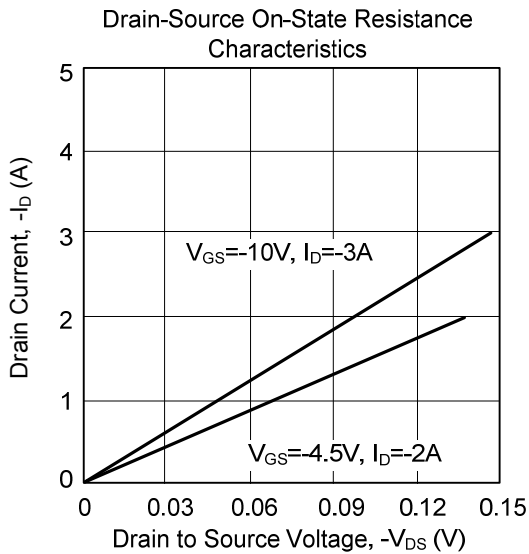
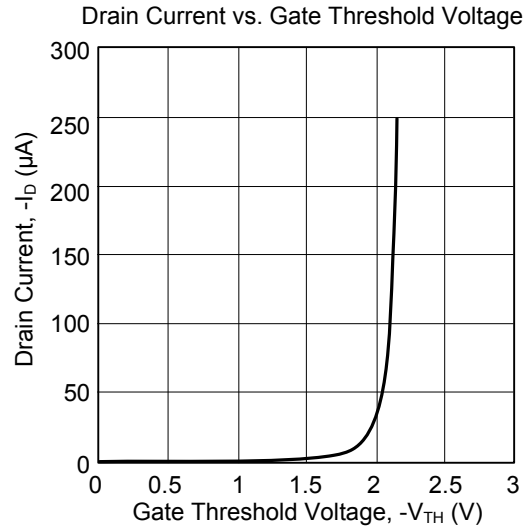
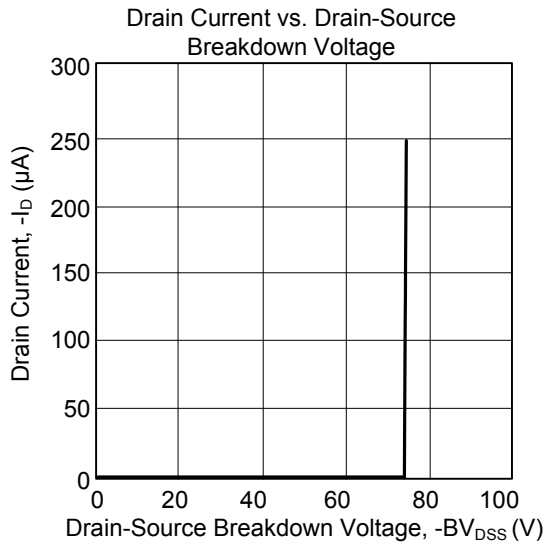

UTC assumes no responsibility for equipment failures that result from using products at values that exceed, even momentarily, rated values (such as maximum ratings, operating condition ranges, or other parameters) listed in products specifications of any and all UTC products described or contained herein. UTC products are not designed for use in life support appliances, devices or systems where malfunction of these products can be reasonably expected to result in personal injury. Reproduction in whole or in part is prohibited without the prior written consent of the copyright owner. The information presented in this document does not form part of any quotation or contract, is believed to be accurate and reliable and may be changed without notice.