

Series E4, E7

Silicon Power Rectifiers

Edal Series E power rectifiers are stud mounted D04 packages. Silicon junctions are securely mounted and hermetically sealed into all metal cases. This design permits extremely reliable operation even under high humidity and other demanding environmental conditions.

A double diffused passivated junction technique is utilized to assure stable uniform electrical characteristics. Inherent in the design of the Series E packages are very low leakage currents as well as good surge handling capability. Series E rectifiers are available in standard, bulk avalanche and fast

recovery types as well as in reverse polarity. Voltage ratings range from 50 to 1500 volts PIV. Because of their broad design and performance characteristics, the Edal Series E silicon rectifiers are ideal for use in applications where economy, power capability and reliability are demanding considerations.

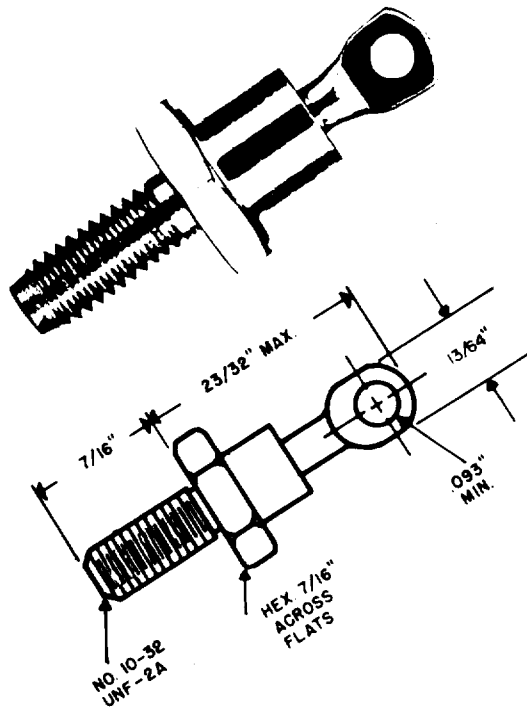

Specifications

PIV VOLTS	16 AMP	22 AMP
50	E4A3	E7A3
100	E4B3	E7B3
200	E4C3	E7C3
250	E4D3	E7D3
300	E4E3	E7E3
350	E4F3	E7F3
400	E4G3	E7G3
500	E4H3	E7H3
600	E4K3	E7K3
700	E4M3	E7M3
800	E4N3	E7N3
1,000	E4P3	E7P3
1,200	E4R3	E7R3
1,500	E4S3	E7S3

Electrical Ratings

1. CATHODE TO STUD. FOR ANODE TO STUD AND SUFFIX "R" TO P/N - EX-E7A3R.
2. TO DESIGNATE FAST RECOVERY TYPES USE LETTERS "R", "S" OR "T" - EX-ES7A3. R=500 nsec; S=200 nsec; T=100 nsec.

	E4	E7
Maximum Forward Current Single Phase Half Wave Case Temperature °C I _o AMPS	126 16	131 22
Maximum Surge Current Single Cycle Amps	200	250
Maximum Forward Drop at 25°C Case I _o AMPS V _f Volts	30 1.3	30 1.2
Maximum Reverse Current FCA @ 150°C ma	1.0	1.0
Maximum I ² T (less than 8 ms) Amps ² -Sec	165	250
Reverse Power for Bulk Available (Joules)	0.16	0.16
Storage Temperature °C	-55 to +190	-55 to +190
Operating Temperature °C	-40 to +175	-40 to +175
Thermal Impedance Maximum (Junction to Case) °C/Watt Maximum	3.0	2.0
Jedec Style	D04	D04

Typical Forward Characteristics At 25°C

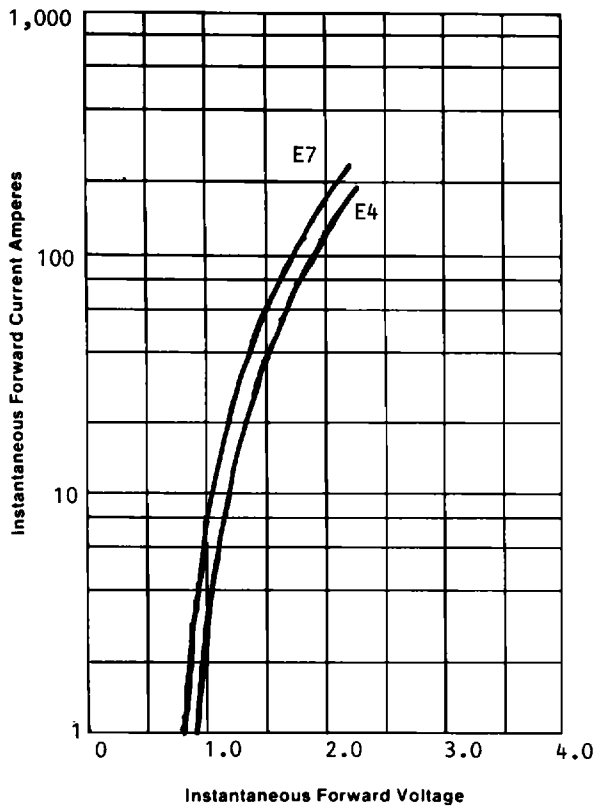

Surge Current at Rated Load

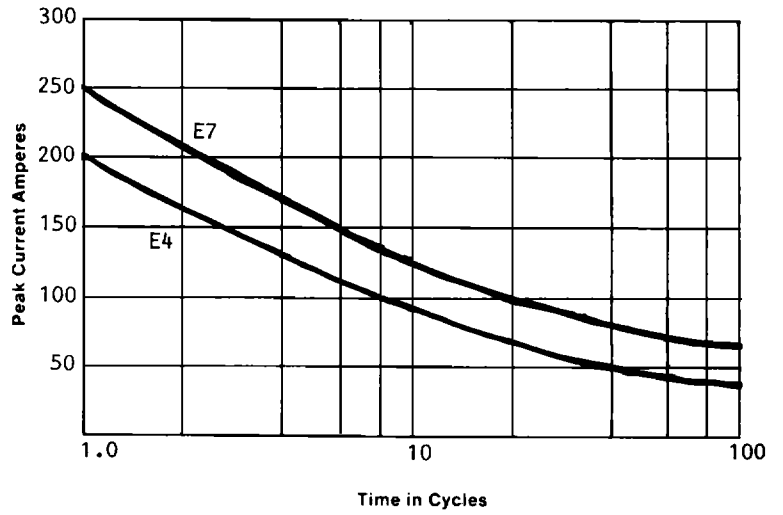

Typical Forward Characteristics At 190°C

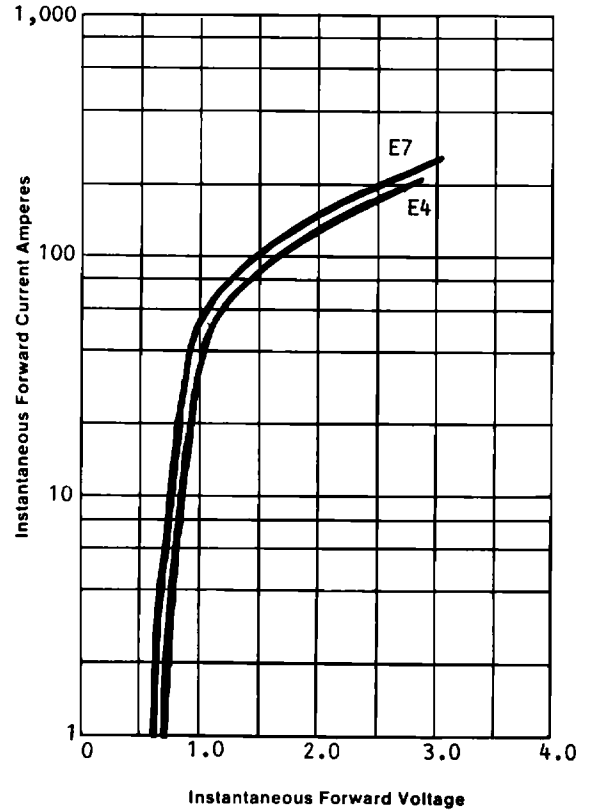

Current Rating

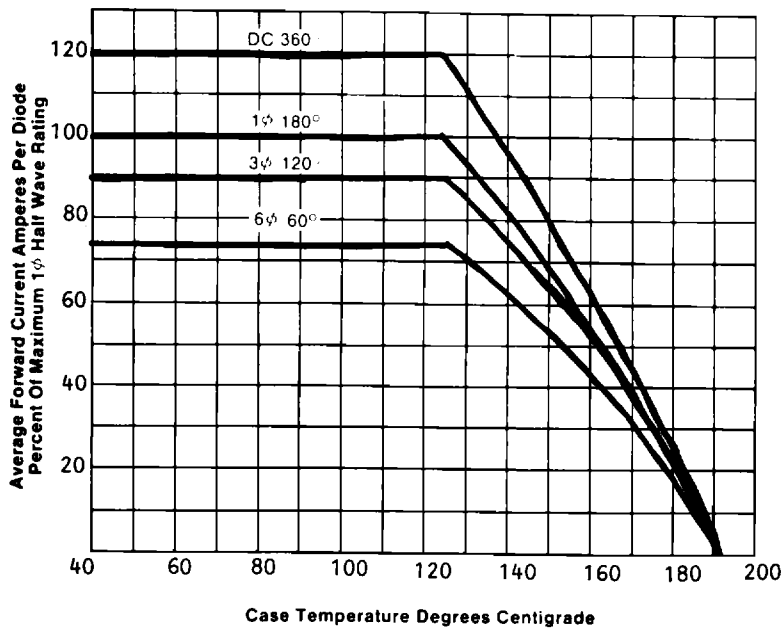

Edal Industries, Inc.