

**Adjustable Low Dropout
 Positive Voltage Regulator**

OM185SR
V_{ADJ}, 3.0A

Product Summary

Part Number	Output Voltage	Output Current	Package
OM185SR	Adjustable	3.0A	D2



Description

These three terminal positive adjustable voltage regulators are designed to provide 3.0A with higher efficiency than conventional voltage regulators. The devices are designed to operate to 1.5V input to output differential and the dropout voltage is specified as a function of load current. Devices are pin compatible with older three terminal regulators and are supplied in the easy-to-use hermetic metal D2 package. These devices are ideally suited for Military applications where small size, hermeticity and high reliability are required.

Features

- Operates Down to 1.0V Dropout @ Max Current
- 0.015% Line Regulation
- 0.01% Load Regulation
- 1% Reference Voltage
- Hermetic TO-257AA (Isolated Tab) Package
- Electrically Equivalent to LM1085
- This part is also available in TO-257AA Package as OM185ST

Absolute Maximum Ratings @ T_c = 25°C

Parameter	Symbol	Value	Units
Output Current	I _O	3.0	A
Differential Voltage	V _{DIFF}	29	V
Thermal Resistance, Junction to Case	R _{θJC}	4.2	°C/W
Operating Junction Temperature Range	T _J	-55 to +150	°C
Storage Temperature Range	T _{STG}	-65 to +150	

Electrical Characteristics $T_J = 25^\circ\text{C}$ (Unless Otherwise Specified)

Parameter	Test Conditions	Min.	Typ.	Max.	Units
Reference Voltage	$I_{OUT} = 10\text{mA}$, $(V_{IN} - V_{OUT}) = 3.0\text{V}$	1.238	1.250	1.262	V
	$10\text{mA} \leq I_{OUT} \leq I_{FULL\ LOAD}$, $1.5\text{V} \leq (V_{IN} - V_{OUT}) \leq 25\text{V}$ ③	1.220	1.250	1.270	
Line Regulation	$I_{LOAD} = 10\text{mA}$, $1.5\text{V} \leq (V_{IN} - V_{OUT}) \leq 15\text{V}$	-	0.015	0.2	%
	①②	-	0.035	0.2	
Load Regulation	$(V_{IN} - V_{OUT}) = 3.0\text{V}$, $10\text{mA} \leq I_{OUT} \leq I_{FULL\ LOAD}$	-	0.5	0.8	%
	①②③	-	0.8	1.0	
Dropout Voltage	$\Delta V_{REF} = 1\%$, $I_{OUT} = I_{FULL\ LOAD}$ ④	-	1.3	1.5	V
Current Limit	$(V_{IN} - V_{OUT}) = 5.0\text{V}$	3.0	-	-	A
	$(V_{IN} - V_{OUT}) = 25\text{V}$	0.2	-	-	
Minimum Load Current	$(V_{IN} - V_{OUT}) = 25\text{V}$	-	5.0	10	mA
Thermal Regulation	30ms Pulse Width (Guaranteed by design)	-	0.004	0.02	%/W
Ripple Rejection	$f = 120\text{Hz}$, $C_{Adj} = 25\mu\text{F}$ Tantalum $I_{OUT} = I_{FULL\ LOAD}$ $(V_{IN} - V_{OUT}) = 3.0\text{V}$	60	75	-	dB
Adjust Pin Current		-	55	-	μA
Adjust Pin Current Change	$10\text{mA} \leq I_{OUT} \leq I_{FULL\ LOAD}$ $1.5\text{V} \leq (V_{IN} - V_{OUT}) \leq 25\text{V}$	-	0.2	5.0	
Temperature Stability	$-55^\circ\text{C} \leq T_J \leq +150^\circ\text{C}$	-	0.5	-	%
Long Term Stability	$T_J = 125^\circ\text{C}$, $t = 1000\text{hrs}$	-	0.3	1.0	

Notes

1. Load and line regulation are measured at a constant junction temperature by low duty cycle pulse testing.
2. Line and load regulation are guaranteed up to the maximum power dissipation. Power dissipation is determined by the input/output differential voltage and output current. Guaranteed maximum power dissipation will not be available over the full input/output voltage range.
3. $I_{FULL\ LOAD}$ curve is defined as the minimum value of current limit as a function of input to output voltage. Note that power dissipation is only achievable over a limited range of input to output voltage.
4. Dropout voltage is specified over the full output current range of the device.

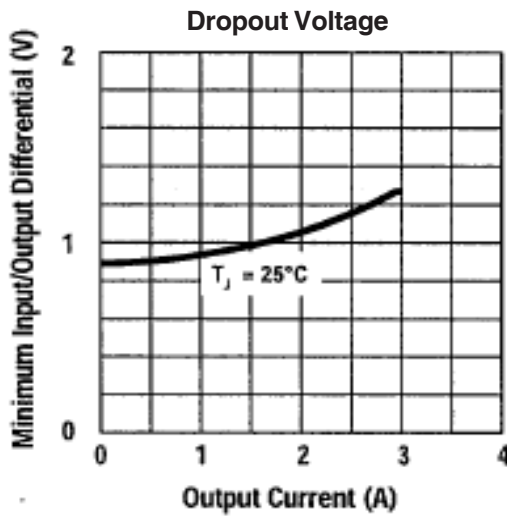

Fig 1: Typical Minimum Input/Output Differential Vs Output Current

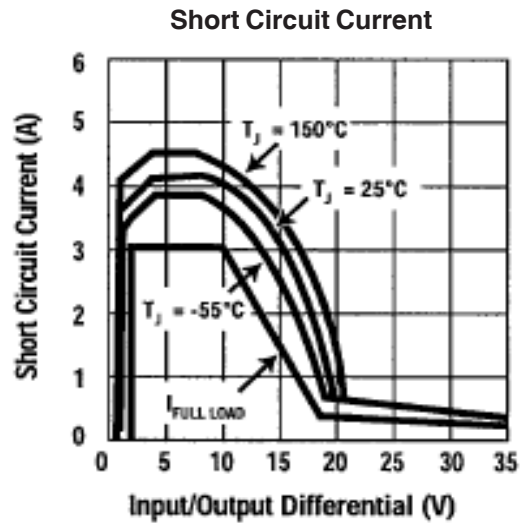

Fig 2: Typical Short Circuit Current Vs Input/Output Differential

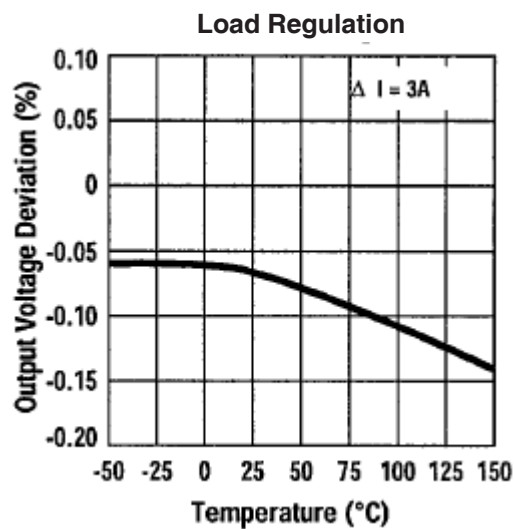

Fig 3: Typical Output Voltage Deviation Vs Temperature

OM185SR

Application Notes: Stability

The OM185SR Series requires the use of an output capacitor as part of the device frequency compensation. For all operating conditions, the addition of 150 μ F aluminum electrolytic or a 22 μ F solid tantalum on the output will ensure stability. Normally, capacitors much smaller than this can be used. Many different types of capacitors with widely varying characteristics are available. These capacitors differ in capacitor tolerance (sometimes ranging up to $\pm 100\%$), equivalent series resistance, and capacitance temperature coefficient. The 150 μ F or 22 μ F values given will ensure stability.

When the adjustment terminal is bypassed to improve the ripple rejection, the requirement for an output capacitor increases. The values of 22 μ F tantalum or 150 μ F aluminum cover all cases of bypassing the adjustment terminal. Without bypassing the adjustment terminal, smaller capacitors can be used with equally good results and the table below shows approximately what size capacitors are needed to ensure stability.

Normally, capacitor values on the order of 100 μ F are used in the output of many regulators to ensure good transient response with heavy load current changes. Output capacitance can be increased without limit and larger values of output capacitor further improve stability and transient response of the regulators.

Recommended Capacitor Values

Input	Output	Adjustment
10 μ F	10 μ F Tantalum, 50 μ F Aluminum	None
10 μ F	22 μ F Tantalum, 150 μ F Aluminum	20 μ F

Output Voltage - Adjustable Regulators

The OM185SR devices develop a 1.25V reference voltage between the output and the adjust terminal (see Fig 4). By placing a resistor, R1 between these two terminals, a constant current is caused to flow through R1 and down through R2 to set the overall output voltage. Normally this current is the specified minimum load current of 10mA. Because I_{ADJ} is very small and constant when compared with the current through R1, it represents a small error and can usually be ignored.

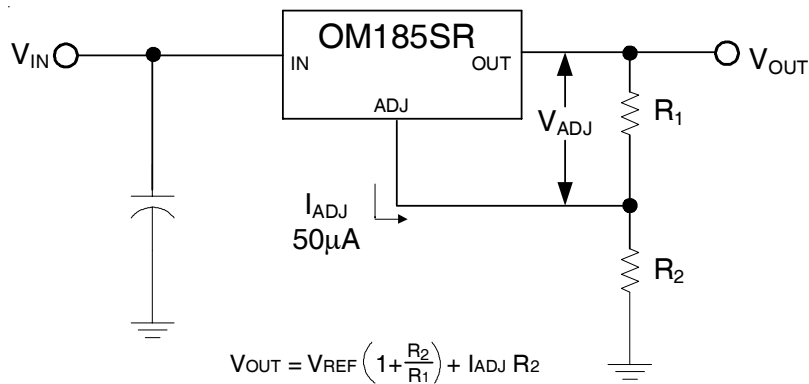
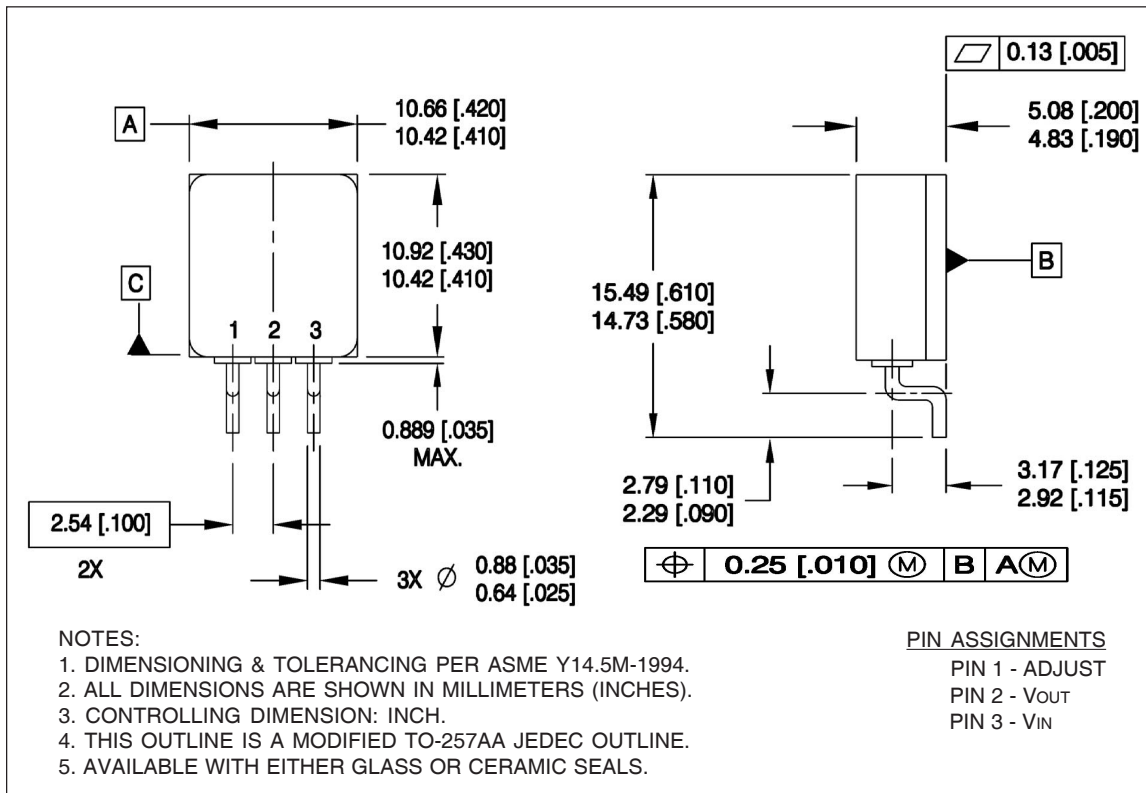

Fig 4. Basic Adjustable Regulator

Case Outline and Dimensions - D2 Package



Part Numbering Nomenclature

