

MULTI-RATE 10-GIGABIT DWDM 40KM XFP TRANSCEIVER WITH DIGITAL DIAGNOSTICS

TXD3XGGI2xx



Product Description

The TXD3XGGI2xx DWDM XFP multi-rate fiber optic transceivers with digital diagnostics monitoring functionality provide a quick and reliable interface for 40km 10Gbps DWDM applications. The diagnostic functions, alarm and warning features as described in the XFP Multi-Source Agreement (MSA) are provided via standard I²C serial interface. The transceivers are compliant with the XFP Multi-Source Agreement and are designed to support SONET/SDH, 10G Ethernet, and 10G Fiber Channel data rates from 9.95Gb/s to 11.09Gb/s.

Each transceiver utilizes an electro-absorption modulator integrated laser with an operating wavelength in full compliance with 100GHz (0.8nm) spacing per the ITU-grid. The transceivers satisfy Class I Laser Safety requirements in accordance with the U.S. FDA/CDRH and international IEC-60825 standards.

The transceivers connect to standard 30-pad XFP connectors for hot plug capability. This allows the system designer to make configuration changes or maintenance by simply plugging in different types of transceivers without removing the power supply from the host system.

The transmitter and receiver DATA interfaces are AC coupled Current Mode Logic (CML). LV-TTL Transmitter Disable control input and Loss of Signal output interfaces are also provided.

The transceivers operate from +3.3V and +5.0V power supplies over a operating case temperature range of -5°C to +70°C (Commercial), -5°C to +85°C (Extended), or -40°C to +85°C (Industrial).

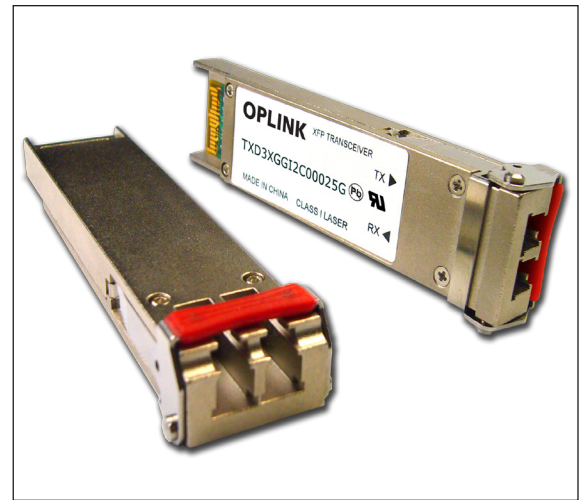

Features

- Lead Free Design & Fully RoHS Compliant
- Compliant with XFP MSA
- Compliant with OC-192/STM-64
- Compliant with ITU-T G.709
- Support DWDM 10G Ethernet Applications
- Support 10G Fiber Channel Applications
- Digital Diagnostics Monitoring
- Temperature-stabilized EML Transmitter
- Low Power Consumption
- Wide Case Operating Temperature Range
- Transmission Distance up to 40km

Absolute Maximum Ratings

Parameter	Symbol	Minimum	Maximum	Units
Storage Temperature	T_{ST}	- 40	+ 85	°C
Operating Case Temperature ¹	Commercial	- 5	+ 70	°C
	Extended	- 5	+ 85	
	Industrial	- 40	+ 85	
Supply Voltage	V_{CC3}	- 0.2	+ 3.6	V
	V_{CC5}	- 0.2	+ 6.0	
Operating Relative Humidity ²	RH	0	85	%
Input Voltage	V_{IN}	0	V_{CC}	V

¹ Case temperature is measured on top side of XFP module.
² Non condensing

Transmitter Performance Characteristics (Over Operating Case Temperature Range)

Parameter	Symbol	Minimum	Typical	Maximum	Units	
Operating Data Rate	B	9.95	-	11.09	Gb/s	
Average Optical Output Power (50% duty cycle)	P_O	- 1.0	-	+ 3.0	dBm	
Transmitter OFF Power	P_{OFF}	-	-	- 45.0	dBm	
Extinction Ratio @ 9.95Gb/s to 10.7Gb/s	ER	8.2	-	-	dB	
Center Wavelength ¹	c	See Ordering Information Table			nm	
Spectral Width (-20dB) ²	$_{20}$	-	-	1.0	nm	
Side Mode Suppression Ratio	$SMSR$	30	-	-	dB	
Relative Intensity Noise	RIN	-	-	- 130	dB/Hz	
Reflectance Tolerance	ref_T	-	-	- 27	dB	
Jitter Generation ³	20 kHz – 80 MHz	JG_{20K}	-	-	0.3	UI _{pp}
	4 MHz – 80 MHz	JG_{4M}	-	-	0.1	UI _{pp}
Dispersion Penalty ⁴	@ 9.95Gb/s (10 ⁻¹² BER)	DP	-	-	2.0	dB
	@ 11.09Gb/s (10 ⁻⁴ BER)		-	-	2.5	
Optical Output Eye	Compliant with GR253-CORE, IEEE 803.3ae, and ITU-T G.959					

¹ BOL: +/-0.05nm from ITU grid. EOL: +/-0.1nm from ITU grid.
² Measured with OSA and 0.1nm resolution bandwidth.
³ Jitter generation is compliant with GR-253 and G.8251.

Receiver Performance Characteristics (Over Operating Case Temperature Range)

Parameter	Symbol	Minimum	Typical	Maximum	Units	
Operating Data Rate	B	9.95	-	11.09	Gb/s	
Wavelength of Operation		1260	-	1570	nm	
Receiver Sensitivity	@ 9.95Gb/s (10 ⁻¹² BER)	P_{min}	-	-	- 16.0	dBm
	@ 11.09Gb/s (10 ⁻⁴ BER)		-	-	- 19.0	
Maximum Input Power	P_{MAX}	+ 0.5	-	-	dBm	
LOS Thresholds	Increasing Light Input	P_{los+}	-	-	- 16.0	dBm
	Decreasing Light Input	P_{los-}	- 28.0	-	-	
LOS Hysteresis	-	0.5	-	-	dB	
Receiver Reflectance	-	-	-	- 27	dB	

Laser Safety: All transceivers are Class I Laser products per FDA/CDRH and IEC-60825 standards. They must be operated under specified operating conditions.



Oplink Communications, Inc.

This product complies with
21 CFR 1040.10 and 1040.11

Meets Class I Laser Safety Requirements



Electrical Interface (Over Operating Case Temperature Range)

Parameter	Symbol	Minimum	Typical	Maximum	Units
Differential Impedance	Z_d	-	100	-	Ω
Differential Input Voltage Swing	$V_{pp, dif, in}$	120	-	820	mV
Differential Output Voltage Swing	$V_{pp, dif, out}$	340	550	850	mV
Output Rise/Fall Time (20 to 80%)	T_r/T_f	24	-	-	ps
TX_Dis, P_Down/RST	V_{IL}	-0.3	-	0.8	V
	V_{IH}	2.0	-	$V_{CC} + 0.3$	
XFP Interrupt, Mod_NR, RX_LOS	V_{OL}	0	-	0.4	V
	V_{OH}	$host_V_{CC} - 0.5$	-	$host_V_{CC} + 0.3$	

Electrical Power Supply Characteristics (Over Operating Case Temperature Range)

Parameter	Symbol	Minimum	Typical	Maximum	Units
Power Supply Voltage	V_{CC3}	3.13	3.3	3.47	V
	V_{CC5}	4.75	5.0	5.25	
Supply Current	I_{CC3}	-	-	750	mA
	I_{CC5}	-	-	500	
Power Dissipation	PW	-	-	3.5	W
P_Down Power Dissipation	PDW	-	-	1.5	W

XFP Transceiver Electrical Pad Layout

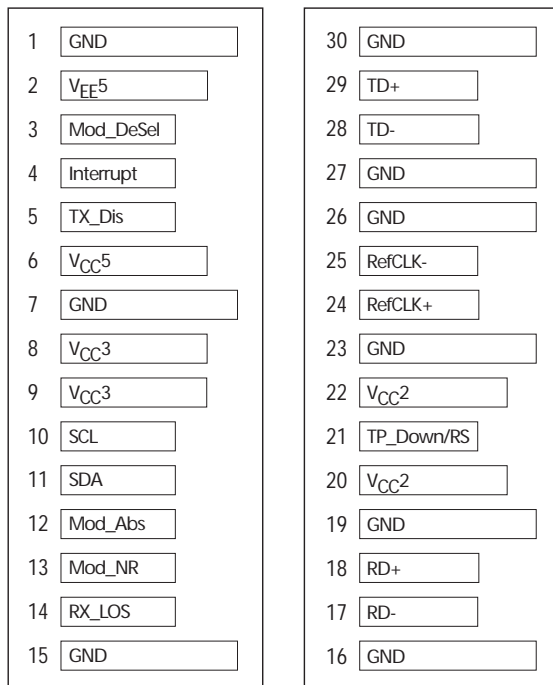

Bottom of XFP Board
(as viewed thru top of board)

Top of XFP Board

Host Board Connector Pad Layout

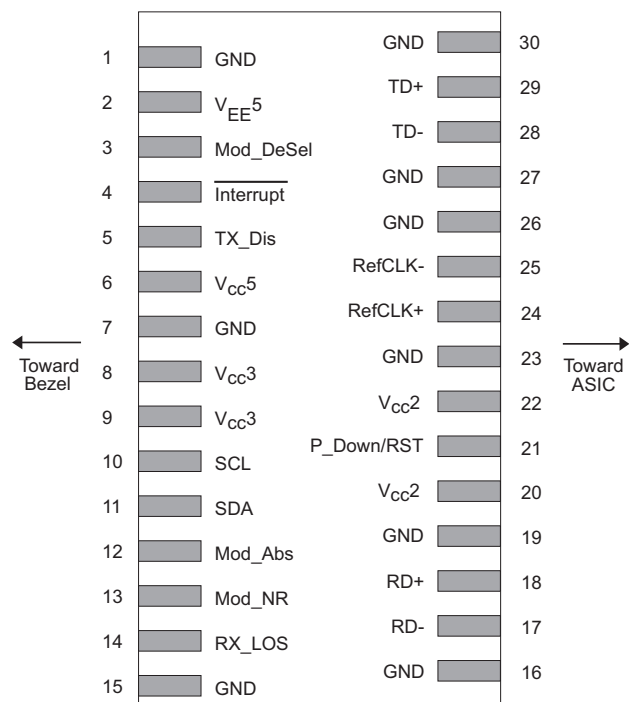

Module Pin Description

Pin	Logic	Symbol	Description
1	-	<i>GND</i>	Module Ground
2	-	V_{EE5}	Optional -5.2V Power Supply (Not Required)
3	<i>LVTTL-I</i>	<i>Mod_DeSel</i>	Module De-select; When held low allows module to respond to 2-wire serial interface
4	<i>LVTTL-O</i>	$\overline{\text{Interrupt}}$	$\overline{\text{Interrupt}}$; Indicates presence of an important condition which can be read over the 2-wire serial Interface
5	<i>LVTTL-I</i>	<i>TX_Dis</i>	Transmitter Disable; Turns off transmitter laser output
6	-	V_{CC5}	+5V Power Supply
7	-	<i>GND</i>	Module Ground
8	-	V_{CC3}	+3.3V Power Supply
9	-	V_{CC3}	+3.3V Power Supply
10	<i>LVTTL-I/O</i>	<i>SCL</i>	2-Wire Serial Interface Clock
11	<i>LVTTL-I/O</i>	<i>SDA</i>	2-Wire Serial Interface Data Line
12	<i>LVTTL-O</i>	<i>Mod_Abs</i>	Indicates Module is not present. Grounded in the Module
13	<i>LVTTL-O</i>	<i>Mod_NR</i>	Module Not Ready; Indicating Module Operational Fault
14	<i>LVTTL-O</i>	<i>RX_LOS</i>	Receiver Loss Of Signal Indicator
15	-	<i>GND</i>	Module Ground
16	-	<i>GND</i>	Module Ground
17	<i>CML-O</i>	<i>RD-</i>	Receiver Inverted Data Output
18	<i>CML-O</i>	<i>RD+</i>	Receiver Non-Inverted Data Output
19	-	<i>GND</i>	Module Ground
20	-	V_{CC2}	Nor Used
21	<i>LVTTL-I</i>	<i>P_Down/RST</i>	Power down; When high, requires the module to limit power consumption to 1.5W or below. 2-Wire serial interface must be functional in the low power mode.
			Reset; The falling edge initiates a complete reset of the module including the 2-wire serial interface, equivalent to a power cycle.
22	-	V_{CC2}	Not Used
23	-	<i>GND</i>	Module Ground
24	<i>PECL-I</i>	<i>RefCLK+</i>	Reference Clock Non-Inverted Input (Not Required)
25	<i>PECL-I</i>	<i>RefCLK-</i>	Reference Clock Inverted Input (Not Required)
26	-	<i>GND</i>	Module Ground
27	-	<i>GND</i>	Module Ground
28	<i>CML-I</i>	<i>TD-</i>	Transmitter Inverted Data Input
29	<i>CML-I</i>	<i>TD+</i>	Transmitter Non-Inverted Data Input
30	-	<i>GND</i>	Module Ground

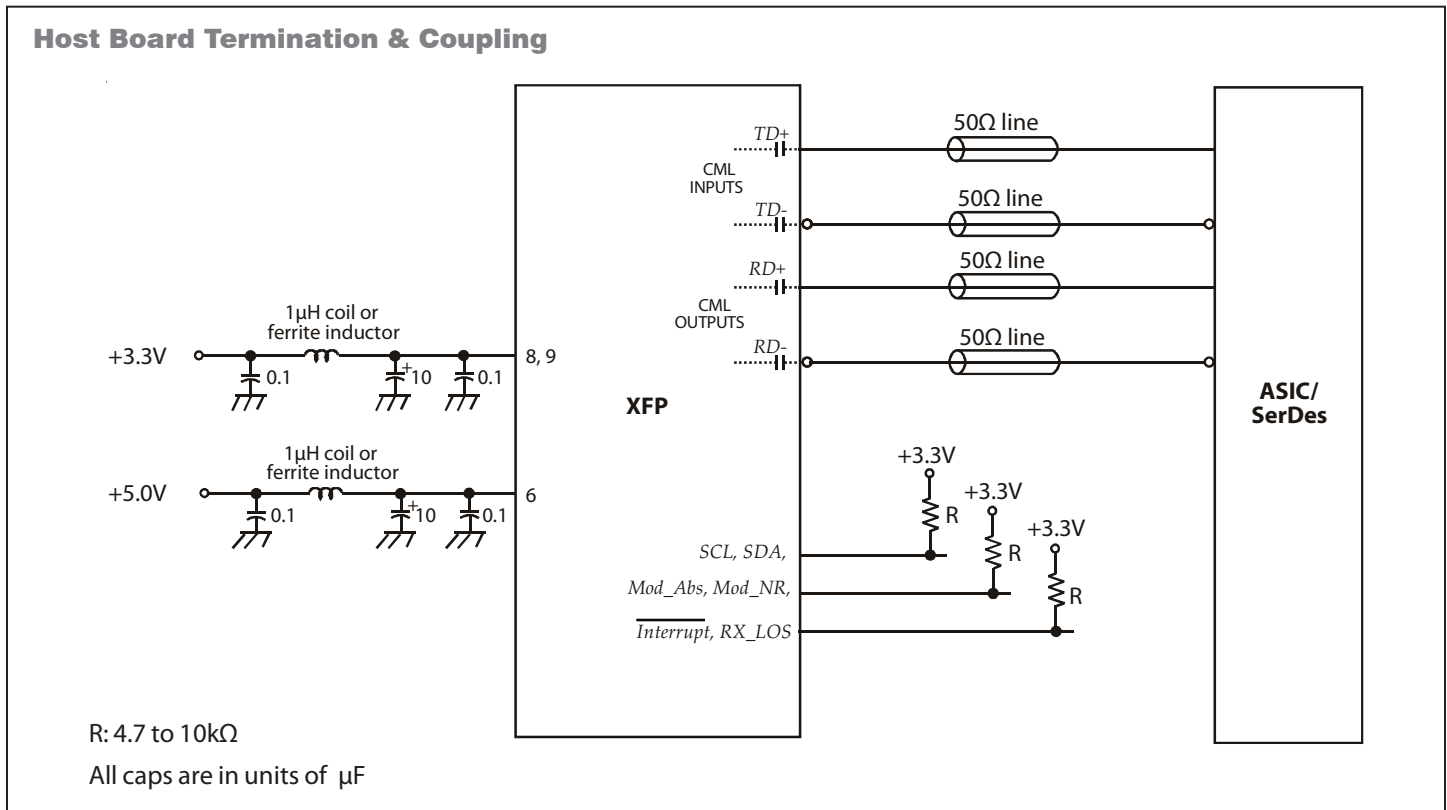

Application Notes

Electrical Interface: All signal interfaces are compliant with the XFP MSA specification. The high speed DATA interface is differential AC-coupled internally and can be directly connected to a 3.3V SERDES IC.

RX_LOS: The Loss of Signal circuit monitors the level of the incoming optical signal and generates a logic HIGH when an insufficient photocurrent is produced.

TX_Dis: When the TX Disable pin is at logic HIGH, the transmitter optical output is disabled. (less than -45dBm).

P_Down: The Power Down Function pin, when held High by the host, places the module in the standby (Low Power) mode with a maximum power dissipation of 1.5W. This protects hosts which are not capable of cooling higher power modules which may be accidentally inserted. The module's 2-wire serial interface and all laser safety functions must be fully functional in this low power mode. During P_Down, the module shall still support the completion of reset Interrupt, as well as maintain functionality of the variable power supply.

Mod_NR: The Mod_NR is an output pin that when High, indicates that the module has detected a condition that renders transmitter and or receiver data invalid, shall consist of logical OR of the following signals:

- Transmit Signal Conditioner Loss of Lock
- Transmitter Laser Fault
- Receiver Signal Conditioner Loss of Lock

Other conditions deemed valuable to the detection of fault may

be added to the Mod_NR. The Mod_NR output pin is an open collector and must be pulled to Host_Vcc on the host board.

P_Down/RST: The negative edge of Reset Function signal initiates a complete module reset.

Module Behavior During P_Down and RST: During execution of a reset (t_{init}) or while held in Power Down mode, a module may be unable to determine the correct value for Mod_NR and RX_LOS. These outputs as well as all interrupt related flags, except completion of Reset flag, shall be disregarded by the host. When the module completes a Reset and is not in Power Down mode, the module must represent the correct value of both signals on its outputs before posting a completion of reset interrupt to the host.

At no time shall a module cause spurious assertion of the $\overline{\text{Interrupt}}$ pin. When a host initially applies power to a module with the P_Down/RST signal asserted, a module comes up in power down mode. The module shall only assert the $\overline{\text{Interrupt}}$ signal pin to inform the host it has completed a reset. The completion of reset flag shall be the only interrupt source flag set during power down mode. The host is expected to clear this interrupt before releasing the module from the power down mode. The transition from power down mode to normal mode will trigger a reset of the module and result in a 2nd module reset and a 2nd reset completion interrupt to the host.

Power Supply and Grounding: The power supply line should be well-filtered. All 0.1μF power supply bypass capacitors should be as close to the transceiver module as possible.

Package Outline

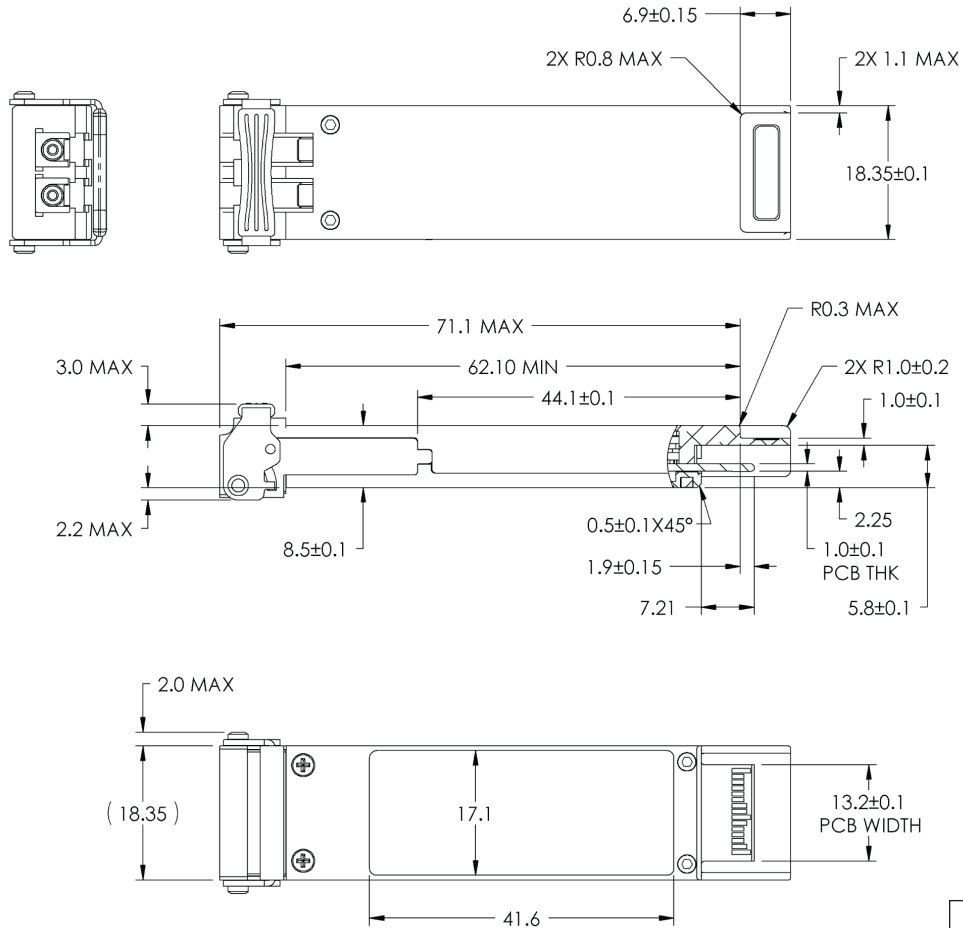

DIMENSION IN MILLIMETERS
 NOTES: UNLESS OTHERWISE SPECIFIED

Ordering Information

Oplink can provide a remarkable range of customized optical solutions. For detail, please contact Oplink’s Sales and Marketing for your requirements and ordering information (510) 933-7200 or Sales@oplink.com.

Model Name	Operating Temperature		Center Wavelength (nm)	ITU Frequency (THz)	Wavelength Reference	Latch Color	Distance
TXD3XGGI2C00061G	-5°C to +70°C	Commercial	1528.77	196.1	61	Red	40km
TXD3XGGI2C00060G	-5°C to +70°C	Commercial	1529.55	196	60	Red	40km
TXD3XGGI2C00059G	-5°C to +70°C	Commercial	1530.33	195.9	59	Red	40km
TXD3XGGI2C00058G	-5°C to +70°C	Commercial	1531.12	195.8	58	Red	40km
TXD3XGGI2C00057G	-5°C to +70°C	Commercial	1531.90	195.7	57	Red	40km
TXD3XGGI2C00056G	-5°C to +70°C	Commercial	1532.68	195.6	56	Red	40km
TXD3XGGI2C00055G	-5°C to +70°C	Commercial	1533.47	195.5	55	Red	40km
TXD3XGGI2C00054G	-5°C to +70°C	Commercial	1534.25	195.4	54	Red	40km
TXD3XGGI2C00053G	-5°C to +70°C	Commercial	1535.04	195.3	53	Red	40km
TXD3XGGI2C00052G	-5°C to +70°C	Commercial	1535.82	195.2	52	Red	40km
TXD3XGGI2C00051G	-5°C to +70°C	Commercial	1536.61	195.1	51	Red	40km
TXD3XGGI2C00050G	-5°C to +70°C	Commercial	1537.40	195.0	50	Red	40km
TXD3XGGI2C00049G	-5°C to +70°C	Commercial	1538.19	194.9	49	Red	40km
TXD3XGGI2C00048G	-5°C to +70°C	Commercial	1538.98	194.8	48	Red	40km

Model Name	Operating Temperature		Center Wavelength (nm)	ITU Frequency (THz)	Wavelength Reference	Latch Color	Distance
TXD3XGGI2C00047G	-5°C to +70°C	Commercial	1539.77	194.7	47	Red	40km
TXD3XGGI2C00046G	-5°C to +70°C	Commercial	1540.56	194.6	46	Red	40km
TXD3XGGI2C00045G	-5°C to +70°C	Commercial	1541.35	194.5	45	Red	40km
TXD3XGGI2C00044G	-5°C to +70°C	Commercial	1542.14	194.4	44	Red	40km
TXD3XGGI2C00043G	-5°C to +70°C	Commercial	1542.94	194.3	43	Red	40km
TXD3XGGI2C00042G	-5°C to +70°C	Commercial	1543.73	194.2	42	Red	40km
TXD3XGGI2C00041G	-5°C to +70°C	Commercial	1544.53	194.1	41	Red	40km
TXD3XGGI2C00040G	-5°C to +70°C	Commercial	1545.32	194.0	40	Red	40km
TXD3XGGI2C00039G	-5°C to +70°C	Commercial	1546.12	193.9	39	Red	40km
TXD3XGGI2C00038G	-5°C to +70°C	Commercial	1546.92	193.8	38	Red	40km
TXD3XGGI2C00037G	-5°C to +70°C	Commercial	1547.72	193.7	37	Red	40km
TXD3XGGI2C00036G	-5°C to +70°C	Commercial	1548.51	193.6	36	Red	40km
TXD3XGGI2C00035G	-5°C to +70°C	Commercial	1549.32	193.5	35	Red	40km
TXD3XGGI2C00034G	-5°C to +70°C	Commercial	1550.12	193.4	34	Red	40km
TXD3XGGI2C00033G	-5°C to +70°C	Commercial	1550.92	193.3	33	Red	40km
TXD3XGGI2C00032G	-5°C to +70°C	Commercial	1551.72	193.2	32	Red	40km
TXD3XGGI2C00031G	-5°C to +70°C	Commercial	1552.52	193.1	31	Red	40km
TXD3XGGI2C00030G	-5°C to +70°C	Commercial	1553.33	193.0	30	Red	40km
TXD3XGGI2C00029G	-5°C to +70°C	Commercial	1554.13	192.9	29	Red	40km
TXD3XGGI2C00028G	-5°C to +70°C	Commercial	1554.94	192.8	28	Red	40km
TXD3XGGI2C00027G	-5°C to +70°C	Commercial	1555.75	192.7	27	Red	40km
TXD3XGGI2C00026G	-5°C to +70°C	Commercial	1556.55	192.6	26	Red	40km
TXD3XGGI2C00025G	-5°C to +70°C	Commercial	1557.36	192.5	25	Red	40km
TXD3XGGI2C00024G	-5°C to +70°C	Commercial	1558.17	192.4	24	Red	40km
TXD3XGGI2C00023G	-5°C to +70°C	Commercial	1558.98	192.3	23	Red	40km
TXD3XGGI2C00022G	-5°C to +70°C	Commercial	1559.79	192.2	22	Red	40km
TXD3XGGI2C00021G	-5°C to +70°C	Commercial	1560.61	192.1	21	Red	40km
TXD3XGGI2C00020G	-5°C to +70°C	Commercial	1561.42	192.0	20	Red	40km
TXD3XGGI2C00019G	-5°C to +70°C	Commercial	1562.23	191.9	19	Red	40km
TXD3XGGI2C00018G	-5°C to +70°C	Commercial	1563.05	191.8	18	Red	40km
TXD3XGGI2C00017G	-5°C to +70°C	Commercial	1563.86	191.7	17	Red	40km

Model Name	Operating Temperature		Center Wavelength (nm)	ITU Frequency (THz)	Wavelength Reference	Latch Color	Distance
TXD3XGGI2E00061G	-5°C to +85°C	Extended	1528.77	196.1	61	Red	40km
TXD3XGGI2E00060G	-5°C to +85°C	Extended	1529.55	196	60	Red	40km
TXD3XGGI2E00059G	-5°C to +85°C	Extended	1530.33	195.9	59	Red	40km
TXD3XGGI2E00058G	-5°C to +85°C	Extended	1531.12	195.8	58	Red	40km
TXD3XGGI2E00057G	-5°C to +85°C	Extended	1531.90	195.7	57	Red	40km
TXD3XGGI2E00056G	-5°C to +85°C	Extended	1532.68	195.6	56	Red	40km
TXD3XGGI2E00055G	-5°C to +85°C	Extended	1533.47	195.5	55	Red	40km
TXD3XGGI2E00054G	-5°C to +85°C	Extended	1534.25	195.4	54	Red	40km
TXD3XGGI2E00053G	-5°C to +85°C	Extended	1535.04	195.3	53	Red	40km

Model Name	Operating Temperature		Center Wavelength (nm)	ITU Frequency (THz)	Wavelength Reference	Latch Color	Distance
TXD3XGGI2E00052G	-5°C to +85°C	Extended	1535.82	195.2	52	Red	40km
TXD3XGGI2E00051G	-5°C to +85°C	Extended	1536.61	195.1	51	Red	40km
TXD3XGGI2E00050G	-5°C to +85°C	Extended	1537.40	195.0	50	Red	40km
TXD3XGGI2E00049G	-5°C to +85°C	Extended	1538.19	194.9	49	Red	40km
TXD3XGGI2E00048G	-5°C to +85°C	Extended	1538.98	194.8	48	Red	40km
TXD3XGGI2E00047G	-5°C to +85°C	Extended	1539.77	194.7	47	Red	40km
TXD3XGGI2E00046G	-5°C to +85°C	Extended	1540.56	194.6	46	Red	40km
TXD3XGGI2E00045G	-5°C to +85°C	Extended	1541.35	194.5	45	Red	40km
TXD3XGGI2E00044G	-5°C to +85°C	Extended	1542.14	194.4	44	Red	40km
TXD3XGGI2E00043G	-5°C to +85°C	Extended	1542.94	194.3	43	Red	40km
TXD3XGGI2E00042G	-5°C to +85°C	Extended	1543.73	194.2	42	Red	40km
TXD3XGGI2E00041G	-5°C to +85°C	Extended	1544.53	194.1	41	Red	40km
TXD3XGGI2E00040G	-5°C to +85°C	Extended	1545.32	194.0	40	Red	40km
TXD3XGGI2E00039G	-5°C to +85°C	Extended	1546.12	193.9	39	Red	40km
TXD3XGGI2E00038G	-5°C to +85°C	Extended	1546.92	193.8	38	Red	40km
TXD3XGGI2E00037G	-5°C to +85°C	Extended	1547.72	193.7	37	Red	40km
TXD3XGGI2E00036G	-5°C to +85°C	Extended	1548.51	193.6	36	Red	40km
TXD3XGGI2E00035G	-5°C to +85°C	Extended	1549.32	193.5	35	Red	40km
TXD3XGGI2E00034G	-5°C to +85°C	Extended	1550.12	193.4	34	Red	40km
TXD3XGGI2E00033G	-5°C to +85°C	Extended	1550.92	193.3	33	Red	40km
TXD3XGGI2E00032G	-5°C to +85°C	Extended	1551.72	193.2	32	Red	40km
TXD3XGGI2E00031G	-5°C to +85°C	Extended	1552.52	193.1	31	Red	40km
TXD3XGGI2E00030G	-5°C to +85°C	Extended	1553.33	193.0	30	Red	40km
TXD3XGGI2E00029G	-5°C to +85°C	Extended	1554.13	192.9	29	Red	40km
TXD3XGGI2E00028G	-5°C to +85°C	Extended	1554.94	192.8	28	Red	40km
TXD3XGGI2E00027G	-5°C to +85°C	Extended	1555.75	192.7	27	Red	40km
TXD3XGGI2E00026G	-5°C to +85°C	Extended	1556.55	192.6	26	Red	40km
TXD3XGGI2E00025G	-5°C to +85°C	Extended	1557.36	192.5	25	Red	40km
TXD3XGGI2E00024G	-5°C to +85°C	Extended	1558.17	192.4	24	Red	40km
TXD3XGGI2E00023G	-5°C to +85°C	Extended	1558.98	192.3	23	Red	40km
TXD3XGGI2E00022G	-5°C to +85°C	Extended	1559.79	192.2	22	Red	40km
TXD3XGGI2E00021G	-5°C to +85°C	Extended	1560.61	192.1	21	Red	40km
TXD3XGGI2E00020G	-5°C to +85°C	Extended	1561.42	192.0	20	Red	40km
TXD3XGGI2E00019G	-5°C to +85°C	Extended	1562.23	191.9	19	Red	40km
TXD3XGGI2E00018G	-5°C to +85°C	Extended	1563.05	191.8	18	Red	40km
TXD3XGGI2E00017G	-5°C to +85°C	Extended	1563.86	191.7	17	Red	40km

Model Name	Operating Temperature		Center Wavelength (nm)	ITU Frequency (THz)	Wavelength Reference	Latch Color	Distance
TXD3XGGI2I00061G	-40°C to +85°C	Industrial	1528.77	196.1	61	Red	40km
TXD3XGGI2I00060G	-40°C to +85°C	Industrial	1529.55	196	60	Red	40km
TXD3XGGI2I00059G	-40°C to +85°C	Industrial	1530.33	195.9	59	Red	40km
TXD3XGGI2I00058G	-40°C to +85°C	Industrial	1531.12	195.8	58	Red	40km

Model Name	Operating Temperature		Center Wavelength (nm)	ITU Frequency (THz)	Wavelength Reference	Latch Color	Distance
TXD3XGGI2I00057G	- 40°C to +85°C	Industrial	1531.90	195.7	57	Red	40km
TXD3XGGI2I00056G	- 40°C to +85°C	Industrial	1532.68	195.6	56	Red	40km
TXD3XGGI2I00055G	- 40°C to +85°C	Industrial	1533.47	195.5	55	Red	40km
TXD3XGGI2I00054G	- 40°C to +85°C	Industrial	1534.25	195.4	54	Red	40km
TXD3XGGI2I00053G	- 40°C to +85°C	Industrial	1535.04	195.3	53	Red	40km
TXD3XGGI2I00052G	- 40°C to +85°C	Industrial	1535.82	195.2	52	Red	40km
TXD3XGGI2I00051G	- 40°C to +85°C	Industrial	1536.61	195.1	51	Red	40km
TXD3XGGI2I00050G	- 40°C to +85°C	Industrial	1537.40	195.0	50	Red	40km
TXD3XGGI2I00049G	- 40°C to +85°C	Industrial	1538.19	194.9	49	Red	40km
TXD3XGGI2I00048G	- 40°C to +85°C	Industrial	1538.98	194.8	48	Red	40km
TXD3XGGI2I00047G	- 40°C to +85°C	Industrial	1539.77	194.7	47	Red	40km
TXD3XGGI2I00046G	- 40°C to +85°C	Industrial	1540.56	194.6	46	Red	40km
TXD3XGGI2I00045G	- 40°C to +85°C	Industrial	1541.35	194.5	45	Red	40km
TXD3XGGI2I00044G	- 40°C to +85°C	Industrial	1542.14	194.4	44	Red	40km
TXD3XGGI2I00043G	- 40°C to +85°C	Industrial	1542.94	194.3	43	Red	40km
TXD3XGGI2I00042G	- 40°C to +85°C	Industrial	1543.73	194.2	42	Red	40km
TXD3XGGI2I00041G	- 40°C to +85°C	Industrial	1544.53	194.1	41	Red	40km
TXD3XGGI2I00040G	- 40°C to +85°C	Industrial	1545.32	194.0	40	Red	40km
TXD3XGGI2I00039G	- 40°C to +85°C	Industrial	1546.12	193.9	39	Red	40km
TXD3XGGI2I00038G	- 40°C to +85°C	Industrial	1546.92	193.8	38	Red	40km
TXD3XGGI2I00037G	- 40°C to +85°C	Industrial	1547.72	193.7	37	Red	40km
TXD3XGGI2I00036G	- 40°C to +85°C	Industrial	1548.51	193.6	36	Red	40km
TXD3XGGI2I00035G	- 40°C to +85°C	Industrial	1549.32	193.5	35	Red	40km
TXD3XGGI2I00034G	- 40°C to +85°C	Industrial	1550.12	193.4	34	Red	40km
TXD3XGGI2I00033G	- 40°C to +85°C	Industrial	1550.92	193.3	33	Red	40km
TXD3XGGI2I00032G	- 40°C to +85°C	Industrial	1551.72	193.2	32	Red	40km
TXD3XGGI2I00031G	- 40°C to +85°C	Industrial	1552.52	193.1	31	Red	40km
TXD3XGGI2I00030G	- 40°C to +85°C	Industrial	1553.33	193.0	30	Red	40km
TXD3XGGI2I00029G	- 40°C to +85°C	Industrial	1554.13	192.9	29	Red	40km
TXD3XGGI2I00028G	- 40°C to +85°C	Industrial	1554.94	192.8	28	Red	40km
TXD3XGGI2I00027G	- 40°C to +85°C	Industrial	1555.75	192.7	27	Red	40km
TXD3XGGI2I00026G	- 40°C to +85°C	Industrial	1556.55	192.6	26	Red	40km
TXD3XGGI2I00025G	- 40°C to +85°C	Industrial	1557.36	192.5	25	Red	40km
TXD3XGGI2I00024G	- 40°C to +85°C	Industrial	1558.17	192.4	24	Red	40km
TXD3XGGI2I00023G	- 40°C to +85°C	Industrial	1558.98	192.3	23	Red	40km
TXD3XGGI2I00022G	- 40°C to +85°C	Industrial	1559.79	192.2	22	Red	40km
TXD3XGGI2I00021G	- 40°C to +85°C	Industrial	1560.61	192.1	21	Red	40km
TXD3XGGI2I00020G	- 40°C to +85°C	Industrial	1561.42	192.0	20	Red	40km
TXD3XGGI2I00019G	- 40°C to +85°C	Industrial	1562.23	191.9	19	Red	40km
TXD3XGGI2I00018G	- 40°C to +85°C	Industrial	1563.05	191.8	18	Red	40km
TXD3XGGI2I00017G	- 40°C to +85°C	Industrial	1563.86	191.7	17	Red	40km

Oplink Communications, Inc. reserves the right to make changes in equipment design or specifications without notice. Information supplied by Oplink Communications, Inc. is believed to be accurate and reliable. However, no responsibility is assumed by Oplink Communications, Inc. for its use nor for any infringements of third parties, which may result from its use. No license is granted by implication or otherwise under any patent right of Oplink Communications, Inc.