

# AN-EVAL3BR0665J

30W 16V SMPS Evaluation Board with  
CoolSET<sup>®</sup> F3R ICE3BR0665J

Power Management & Supply



**Edition 2010-08-11**

**Published by Infineon Technologies Asia Pacific,  
8 Kallang Sector,  
349282 Singapore**

**© Infineon Technologies AP 2008.  
All Rights Reserved.**

**Attention please!**

The information herein is given to describe certain components and shall not be considered as a guarantee of characteristics.

Terms of delivery and rights to technical change reserved.

We hereby disclaim any and all warranties, including but not limited to warranties of non-infringement, regarding circuits, descriptions and charts stated herein.

**Information**

For further information on technology, delivery terms and conditions and prices please contact your nearest Infineon Technologies Office ([www.infineon.com](http://www.infineon.com)).

**Warnings**

Due to technical requirements components may contain dangerous substances. For information on the types in question please contact your nearest Infineon Technologies Office.

Infineon Technologies Components may only be used in life-support devices or systems with the express written approval of Infineon Technologies, if a failure of such components can reasonably be expected to cause the failure of that life-support device or system, or to affect the safety or effectiveness of that device or system. Life support devices or systems are intended to be implanted in the human body, or to support and/or maintain and sustain and/or protect human life. If they fail, it is reasonable to assume that the health of the user or other persons may be endangered

---

**30W 16V Demoboard using ICE3BR0665J on board****Revision History:**                   **2010-08**   **V1.1**Previous Version:                   **1.0**

Page	Subjects (major changes since last revision)
1, 5, 7	Change the demo board name to EVAL3BR0665J

---

30W 16V SMPS Evaluation Board with CoolSET®F3R ICE3BR0665J:  
License to Infineon Technologies Asia Pacific Pte Ltd

AN-PS0023

**Kyaw Zin Min**  
**Kok Siu Kam Eric****We Listen to Your Comments**

Any information within this document that you feel is wrong, unclear or missing at all?  
Your feedback will help us to continuously improve the quality of this document.  
Please send your proposal (including a reference to this document) to:

[ap-lab.admin@infineon.com](mailto:ap-lab.admin@infineon.com)

<b>Table of Contents</b>		<b>Page</b>
<b>1</b>	<b>Abstract</b> .....	<b>5</b>
<b>2</b>	<b>Evaluation Board</b> .....	<b>5</b>
<b>3</b>	<b>List of Features</b> .....	<b>6</b>
<b>4</b>	<b>Technical Specifications</b> .....	<b>6</b>
<b>5</b>	<b>Circuit Description</b> .....	<b>7</b>
5.1	Introduction.....	7
5.2	Line Input.....	7
5.3	Start up.....	7
5.4	Operation mode .....	7
5.5	Soft start.....	7
5.6	RCD Clamper circuit .....	7
5.7	Peak current control of primary current.....	7
5.8	Output Stage .....	8
5.9	Feedback and regulation.....	8
5.10	Blanking Window for Load Jump / Active Burst Mode .....	8
5.11	Active Burst Mode .....	8
5.12	Jitter mode.....	8
5.13	Protection modes .....	9
<b>6</b>	<b>Circuit Diagram</b> .....	<b>10</b>
<b>7</b>	<b>PCB Layout</b> .....	<b>12</b>
7.1	Component side component legend .....	12
7.2	Solder side copper & component legend .....	12
<b>8</b>	<b>Component List</b> .....	<b>14</b>
<b>9</b>	<b>Transformer Construction</b> .....	<b>15</b>
<b>10</b>	<b>Test Results</b> .....	<b>16</b>
10.1	Efficiency.....	16
10.2	Input Standby Power .....	17
10.3	Line Regulation .....	18
10.4	Load Regulation .....	19
10.5	Max. Output Power .....	19
10.6	ESD Test.....	20
10.7	Lightning Surge Test.....	20
10.8	Conducted EMI.....	20
<b>11</b>	<b>Waveforms and Scope Plots</b> .....	<b>22</b>
11.1	Start up at low and high AC line input voltage and 30W load.....	22
11.2	Soft start at low and high AC line input voltage and 30W load .....	22
11.3	Frequency jittering.....	23
11.4	Drain to source voltage and Current at 30W load.....	23
11.5	Load transient response (Load jump from 10% to 100%) .....	24
11.6	AC output ripple voltage at 30W load .....	24
11.7	Active burst mode at 0.5W load .....	25
11.8	Vcc overvoltage protection – Auto Restart.....	26
11.9	Over load protection – Auto Restart.....	27
11.10	Open loop protection – Auto Restart.....	27
11.11	Vcc under voltage/Short optocoupler protection– Auto Restart.....	28
11.12	External auto restart enable .....	28
<b>12</b>	<b>Appendix</b> .....	<b>29</b>
12.1	Slope compensation for CCM operation .....	29
<b>13</b>	<b>References</b> .....	<b>29</b>

## 1 Abstract

This document is an engineering report of a universal input 30W 16V off line fly back converter power supply utilizing IFX F3R CoolSET<sup>®1</sup> ICE3BR0665J. The application demo board is operated in Discontinuous Conduction Mode (DCM) and is running at 65 kHz switching frequency. It has a one output voltage with secondary side control regulation. It is especially suitable for small power supply such as DVD player, set-top box, game console, charger and auxiliary power of high power system, etc. The ICE3BR0665J is the latest version of the CoolSET<sup>®</sup>. Besides having the basic features of the F3R CoolSET<sup>®</sup> such as Active Burst Mode, propagation delay compensation, soft gate drive, auto restart protection for serious fault (Vcc over voltage, Vcc under voltage, over temperature, over-load, open loop and short opto-coupler), it also has the BiCMOS technology design, built-in soft start time, built-in and extendable blanking time, frequency jitter feature with built-in jitter period and external auto-restart enable, etc. The particular features needs to be stressed are the best in class low standby power and the good EMI performance.

## 2 Evaluation Board



Figure 1 – EVAL3BR0665J

This document contains the list of features, the power supply specification, schematic, bill of material and the transformer construction documentation. Typical operating characteristics such as performance curve and scope waveforms are showed at the rear of the report.

<sup>1</sup> CoolSET<sup>®</sup> is a trade mark of Infineon which is a PWM control IC integrated with CoolMOS<sup>®</sup> in one package.

### 3 List of Features

650V avalanche rugged CoolMOS® with built-in Startup Cell
Active Burst Mode for lowest Standby Power
Fast load jump response in Active Burst Mode
65 kHz internally fixed switching frequency
Auto Restart Protection Mode for Over-load, Open Loop, Vcc Under voltage, Over-temperature & Vcc Over-voltage
Built-in Soft Start
Built-in blanking window with extendable blanking time for short duration high current
External auto-restart enable
Max Duty Cycle 75%
Overall tolerance of Current Limiting < ±5%
Internal PWM Leading Edge Blanking
BiCMOS technology provides wide VCC range
Built-in Frequency jitter feature and soft driving for low EMI

### 4 Technical Specifications

Input voltage	85VAC~265VAC
Input frequency	50Hz, 60Hz
Input Standby Power	< 50mW @ no load; < 0.7W @ 0.5W load
Output voltage and current	16V +/- 1%
Output current	1.9A
Output power	30.4W
Efficiency	>85% at full load
Output ripple voltage	< 150mVp-p

## 5 Circuit Description

### 5.1 Introduction

The EVAL3BR0665J demo board is a low cost off line fly back switch mode power supply (SMPS) using the ICE3BR0665J system IC from the CoolSET<sup>®</sup>-F3R family. The circuit, shown in Figure 2, details a 16V, 30W power supply that operates from an AC line input voltage range of 85Vac to 265Vac, suitable for applications in open frame supply or enclosed adapter.

### 5.2 Line Input

The AC line input side comprises the input fuse F1 as over-current protection. The choke L1, X2-capacitors C1, C2 and Y1-capacitor C4 act as EMI suppressors. Spark gap device SG1, SG2 and varistor VAR1 can absorb high voltage stress during lightning surge test. After the bridge rectifier BR1 and the input bulk capacitor C2, a voltage of 120 to 375 V<sub>DC</sub> is present which depends on input voltage.

### 5.3 Start up

Since there is a built-in startup cell in the ICE3BR0665J, there is no need for external start up resistor. The startup cell is connecting the drain pin of the IC. Once the voltage is built up at the Drain pin of the ICE3BR0665J, the startup cell will charge up the Vcc capacitor C6 and C7. When the Vcc voltage exceeds the UVLO at 18V, the IC starts up. Then the Vcc voltage is bootstrapped by the auxiliary winding to sustain the operation.

### 5.4 Operation mode

During operation, the Vcc pin is supplied via a separate transformer winding with associated rectification D2 and buffering C6, C7. Ferrite bead FB1 used to suppress high frequency noise from auxiliary winding which may cause IC to malfunction. In order not to exceed the maximum voltage at Vcc pin, an external zener diode ZD1 and resistor R4 can be added.

### 5.5 Soft start

The Soft-Start is a built-in function and is set at 20ms.

### 5.6 RCD Clamper circuit

While turns off the CoolMOS<sup>®</sup>, the clamper circuit R1, C4 and D1 absorbs the current caused by transformer leakage inductance once the voltage exceeds clamp capacitor voltage. Finally drain to source voltage of CoolMOS<sup>®</sup> is lower than maximum break down voltage ( $V_{(BR)DSS} = 650V^2$ ) of CoolMOS<sup>®</sup>.

### 5.7 Peak current control of primary current

The CoolMOS<sup>®</sup> drain source current is sensed via external shunt resistors R5 and R5A which determine the tolerance of the current limit control. Since ICE3BR0665J is a current mode controller, it would have a cycle-by-cycle primary current and feedback voltage control which can make sure the maximum power of the converter is controlled in every switching cycle. Besides, propagation delay compensation is implemented to ensure the maximum input current/power can be controlled in an even tighter manner. The demo board shows approximately. +/-0.97% (refer to Figure 14).

---

<sup>2</sup>  $V_{(BR)DSS} = 650V @ T_j = 110^\circ C$

## 5.8 Output Stage

On the secondary side the power is coupled out by a schottky diode D3. The capacitor C11 provides energy buffering following with the LC filter L2 and C12 to reduce the output voltage ripple considerably. Storage capacitor C11 is selected to have an internal resistance as small as possible (ESR) to minimize the output voltage ripple. The common mode choke L3 and ceramic capacitor C16 are added to withstand high voltage electrostatic static discharge during ESD test.

## 5.9 Feedback and regulation

The output voltage is controlled using a TL431 (IC3). This device incorporates the voltage reference as well as the error amplifier and a driver stage. Compensation network C14, C15, R8, R10, R11, R12 and R13 constitutes the external circuitry of the error amplifier of IC3. This circuitry allows the feedback to be precisely matched to dynamically varying load conditions and provides stable control. The maximum current through the optocoupler diode and the voltage reference is set by using resistors R6 and R7. Optocoupler IC2 is used for floating transmission of the control signal to the “Feedback” input via capacitor C9 of the ICE3BR0665J control device. The optocoupler used meets DIN VDE 884 requirements for a wider creepage distance.

## 5.10 Blanking Window for Load Jump / Active Burst Mode

In case of Load Jumps the Controller provides a Blanking Window before activating the Over Load Protection and entering the Auto Restart Mode. There are 2 modes for the blanking time setting; basic mode and the extendable mode. If there is no capacitor added to the BA pin, it would fall into the basic mode; i.e. the blanking time is set at 20ms. If a longer blanking time is required, a capacitor, C8 can be added to BA pin to extend it. The extended time can be achieved by an internal 13uA constant current at BA pin to charge C8 from 0.9V to 4.0V. Thus the overall blanking time is the addition of 20ms and the extended time. For example,  $C_{BK}$  (external capacitor at BA pin) = 0.1uF,  $I_{BK}$  (internal charging current) = 13uA

$$t_{blanking} = Basic + Extended = 20ms + \frac{(4.0 - 0.9) \times C_{BK}}{I_{BK}} = 43ms$$

Note: A filter capacitor (e.g. 100pF (min. value)) may be needed to add to the BA pin if the noises cannot be avoided to enter that pin in the physical PCB layout. Otherwise, some protection features may be mis-triggered and the system may not be working properly.

## 5.11 Active Burst Mode

At light load condition, the SMPS enters into Active Burst Mode. At this start, the controller is always active and thus the  $V_{CC}$  must always be kept above the switch off threshold  $V_{CCoff} \geq 10.5V$ . During active burst mode, the efficiency increases significantly and at the same time it supports low ripple on  $V_{OUT}$  and fast response on load jump. When the voltage level at FB falls below 1.35V, the internal blanking timer starts to count. When it reaches the built-in 20ms blanking time, it will enter Active Burst Mode. The Blanking Window is generated to avoid sudden entering of Burst Mode due to load jump.

During Active Burst Mode the current sense voltage limit is reduced from 1V to 0.34V so as to reduce the conduction losses and audible noise. All the internal circuits are switched off except the reference and bias voltages to reduce the total  $V_{CC}$  current consumption to below 0.45mA. At burst mode, the FB voltage is changing like a sawtooth between 3.05 and 3.5V. To leave Burst Mode, FB voltage must exceed 4V. It will reset the Active Burst Mode and turn the SMPS into Normal Operating Mode. Maximum current can then be provided to stabilize  $V_{OUT}$ .

## 5.12 Jitter mode

The ICE3B0665J has frequency jittering feature to reduce the EMI noise. The jitter frequency is internally set at 65 kHz (+/-2.6 kHz) and the jitter period is set at 4ms.



### 5.13 Protection modes

Protection is one of the major factors to determine whether the system is safe and robust. Therefore sufficient protection is necessary. ICE3BR0665J provides all the necessary protections to ensure the system is operating safely. The protections include Vcc over-voltage, over-temperature, over-load, open loop, Vcc under-voltage, short opto-coupler, etc. When those faults are found, the system will go into auto-restart which means the system will stop for a short period of time and re-start again. If the fault persists, the system will stop again. It is then until the fault is removed, the system resumes to normal operation. A list of protections and the failure conditions are showed in the below table.

Protection function	Failure condition	Protection Mode
Vcc Over-voltage	1. Vcc > 25.5V or 2. Vcc > 20.5V & FB > 4.0V & during soft start period	Auto Restart
Over-temperature (controller junction)	$T_J > 130^{\circ}\text{C}$	Auto Restart
Over-load / Open loop	$V_{FB} > 4.0\text{V}$ and $V_{BA} > 4.0\text{V}$ (Blanking time counted from charging $V_{BA}$ from 0.9V to 4.0V )	Auto Restart
Vcc Under-voltage / short Opto-coupler	$V_{cc} < 10.5\text{V}$	Auto Restart
External Auto-restart enable	$V_{BA} < 0.33\text{V}$	Auto Restart

## 6 Circuit Diagram

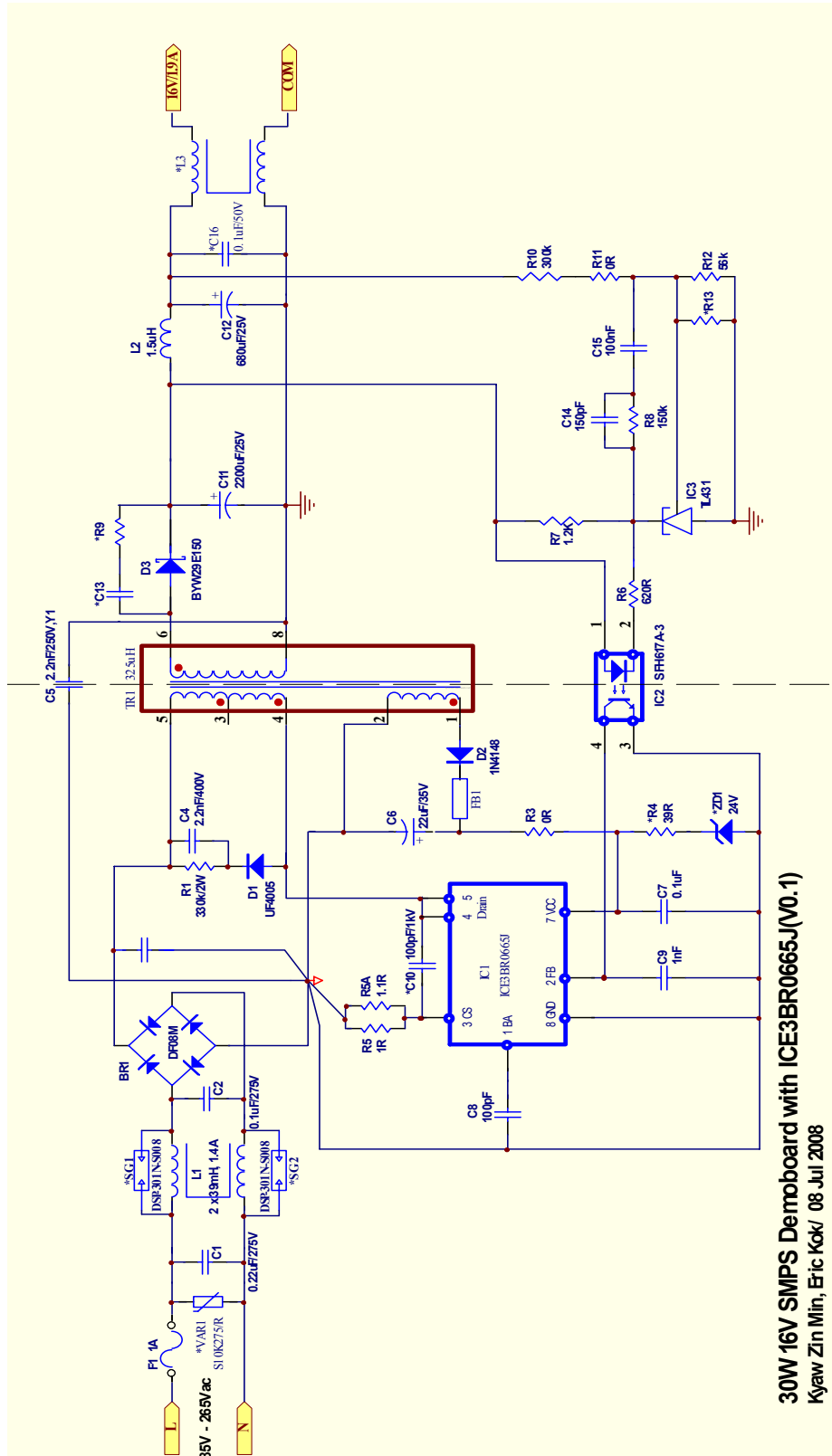

Figure 2 – 30W 16V ICE3BR0665J power supply Schematic

N.B. : In order to get the optimized performance of the CoolSET<sup>®</sup>, the grounding of the PCB layout must be connected very carefully. From the circuit diagram above, it indicates that the grounding for the CoolSET<sup>®</sup> can be split into several groups; signal ground, Vcc ground, Current sense resistor ground and EMI return ground. All the split grounds should be connected to the bulk capacitor ground separately.

- Signal ground includes all small signal grounds connecting to the CoolSET<sup>®</sup> GND pin such as filter capacitor ground, C7, C8, C9 and opto-coupler ground.
- Vcc ground includes the Vcc capacitor ground, C6 and the auxiliary winding ground, pin 2 of the power transformer.
- Current Sense resistor ground includes current sense resistor R5 and R5A.
- EMI return ground includes Y capacitor, C5.

## 7 PCB Layout

### 7.1 Component side component legend

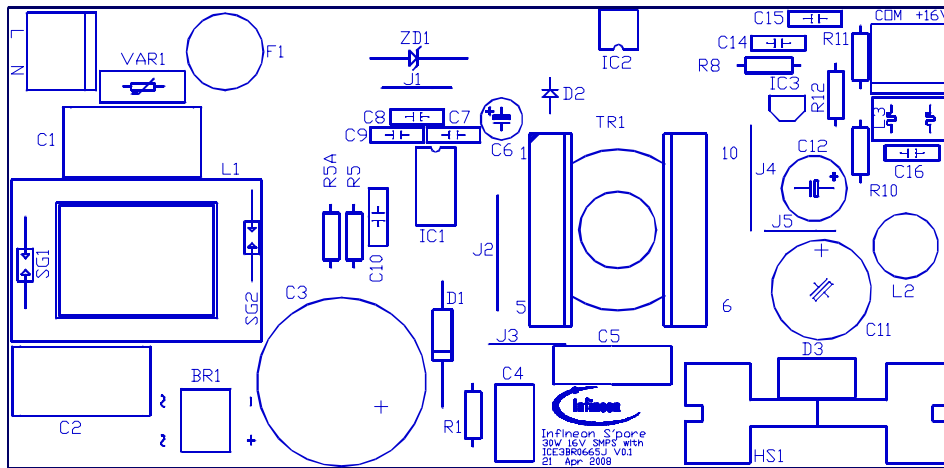

Figure 3 – Component side Component Legend – View from Component Side

### 7.2 Solder side copper & component legend

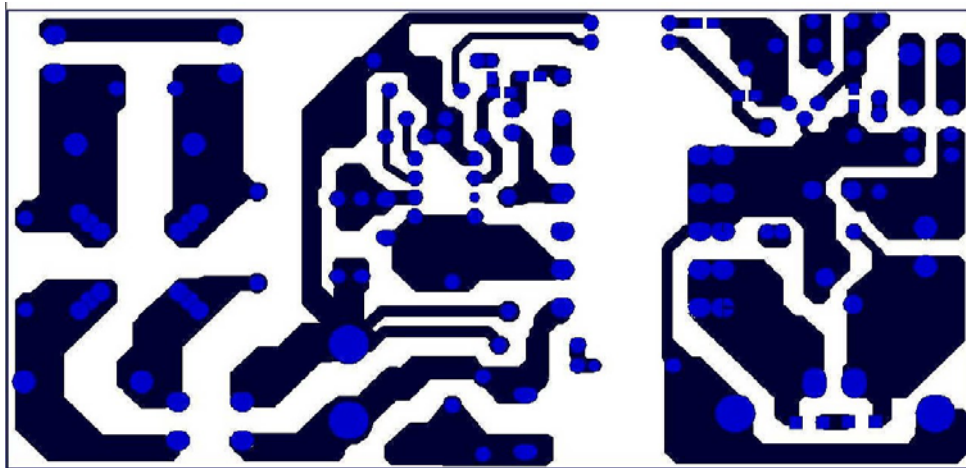
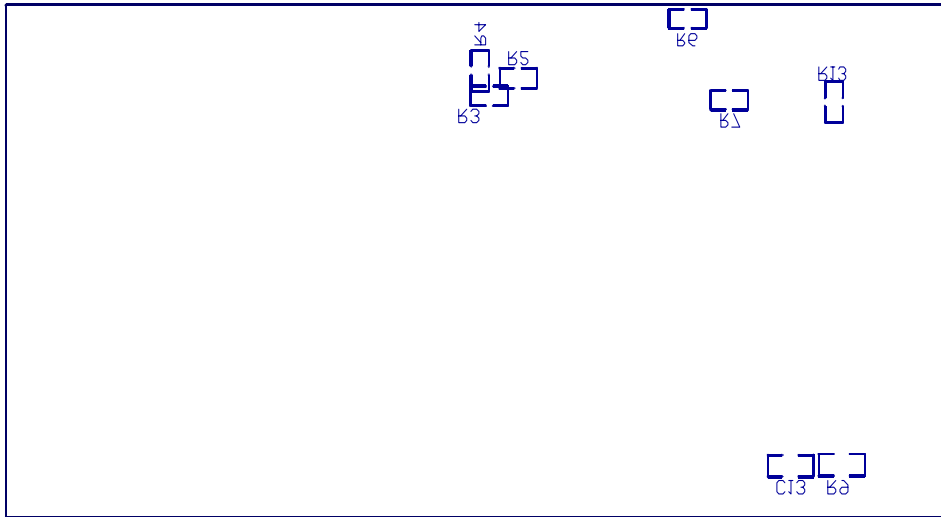

Figure 4 – Solder side copper – View from Component Side



**Figure 5** – Solder side component Legend – View from Component Side

## 8 Component List

No	Ckt Code	Component description	Quantity	Manufacturer
1	BR1	DF08M	1	-
2	C1	0.22 $\mu$ F/275V	1	Epcos
3	C2	0.1 $\mu$ F/275V	1	Epcos
4	C3	68 $\mu$ F/400V	1	Epcos
5	C4	2.2nF/400V	1	Epcos
6	C5	2.2nF/250V	1	Murata
7	C6	22 $\mu$ F/35V	1	Epcos
8	C7	0.1 $\mu$ F	1	Murata
9	C8	100pF	1	Epcos
10	C9	1nF	1	Murata
11	C11	2200 $\mu$ F/25V	1	-
12	C12	680 $\mu$ F/25V	1	-
13	C14	150pF	1	Epcos
14	C15	100nF	1	Murata
15	D1	UF4005	1	-
16	D2	1N4148	1	-
17	D3	BYW29E150	1	-
18	F1	1A Fuse	1	-
19	FB1	Ferrite Bead	1	Epcos
20	IC1	ICE3BR0665J (DIP-8)	1	Infineon
21	IC2	SFH617A-3	1	-
22	IC3	TL431	1	-
23	J1~J5	Jumper	5	-
24	L1	2X39mH,1.4A	1	Epcos
25	L2	1.5 $\mu$ H	1	NEC-Tokin
26	R1	330k $\Omega$ /2W	1	-
27	R3	0 $\Omega$ , (SMD 0805)	1	Rohm
28	R5	1 $\Omega$ (0.5W, 1%)	1	-
29	R5A	1.1 $\Omega$ (0.5W, 1%)	1	-
30	R6	620 $\Omega$	1	Rohm
31	R7	1.2k $\Omega$	1	Rohm
32	R8	150k $\Omega$	1	-
33	R10	300k $\Omega$ ,1%	1	-
34	R11	Jumper	1	-
35	R12	56k $\Omega$ ,1%	1	-
36	TR1	L <sub>p</sub> =325 $\mu$ H, ER28, BH1	1	Epcos

## 9 Transformer Construction

Core: ER28, BH1

Bobbin: Vertical Version

Primary Inductance,  $L_p$ : 325mH (+/-2%) measured between pin 4 and pin 5 (Gapped to Inductance)

### Transformer structure:

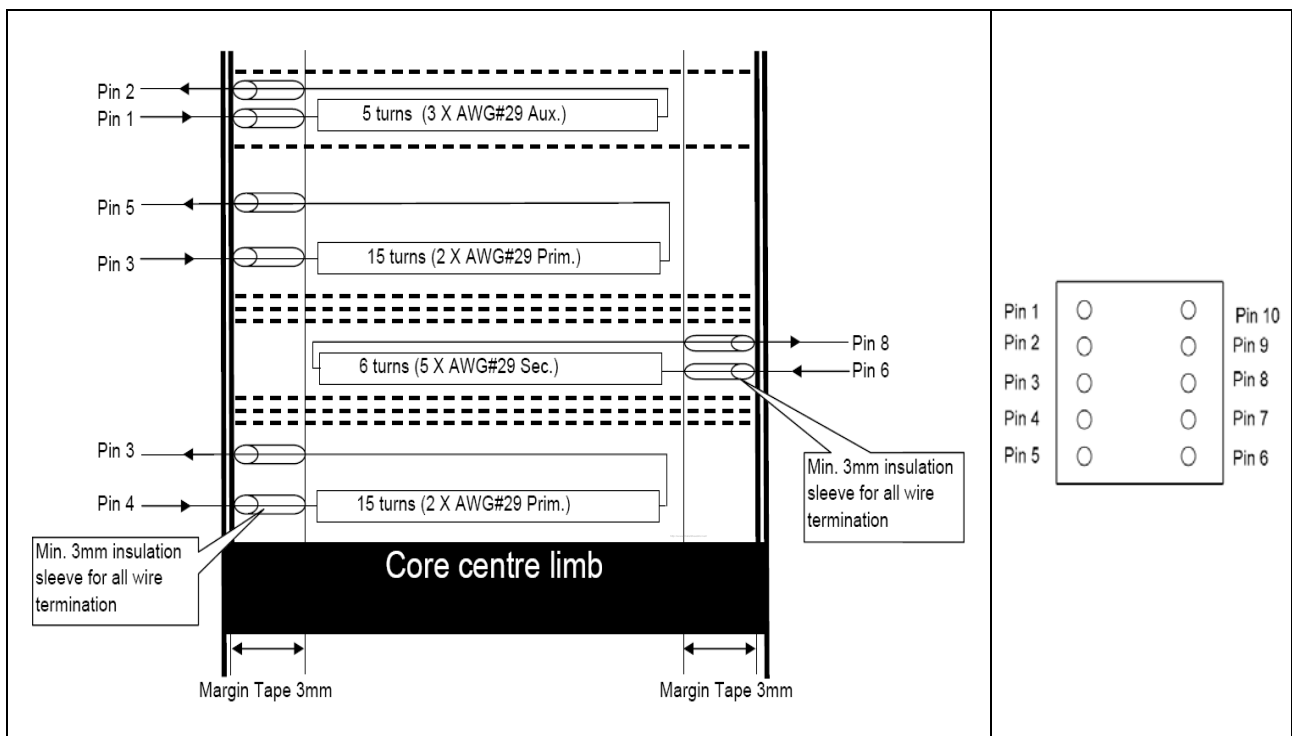

Figure 6 – Transformer structure and top view of transformer complete

### Wire size requirement:

Start	Stop	No. of turns	Wire size	Layer
1	2	5	3XAWG#29	Auxiliary
3	5	15	2XAWG#29	$\frac{1}{2}$ Primary
6	8	6	5XAWG#29	Secondary
4	3	15	2XAWG#29	$\frac{1}{2}$ Primary

## 10 Test Results

### 10.1 Efficiency

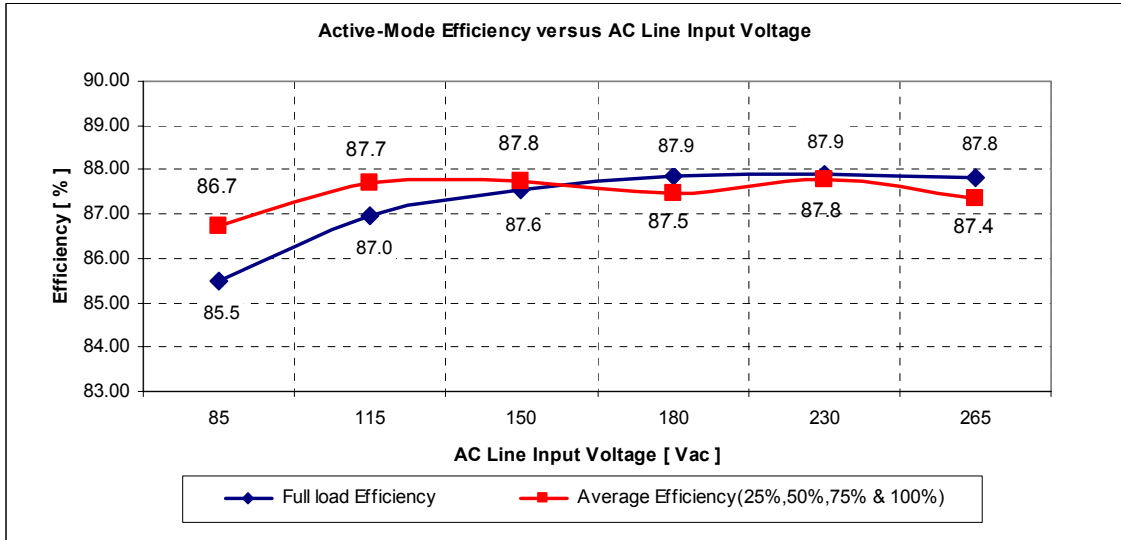

Figure 7 – Efficiency vs. AC Line Input Voltage

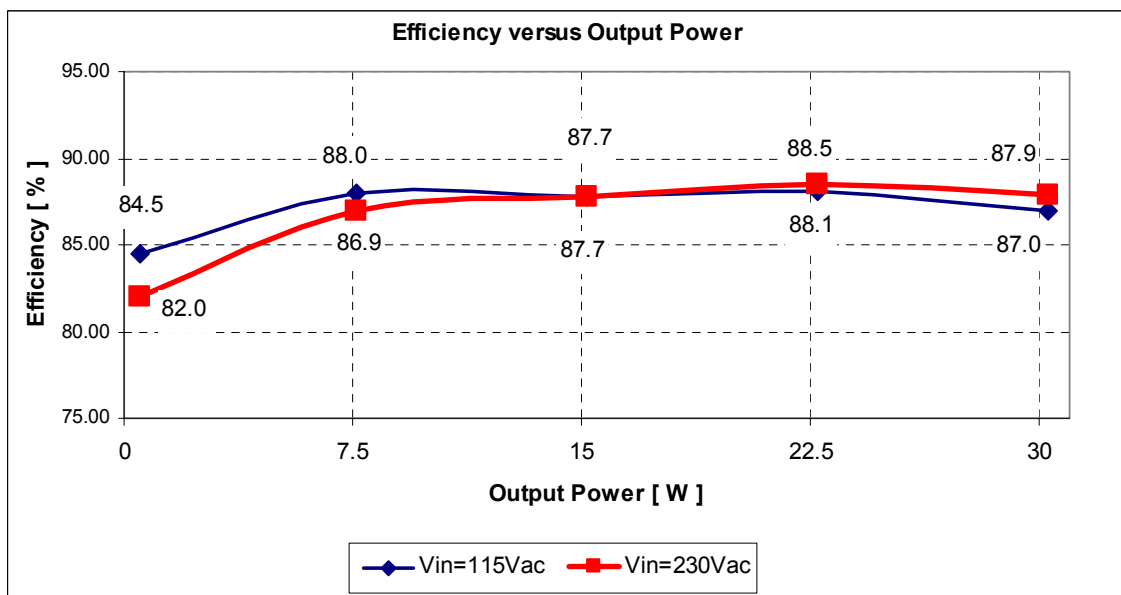
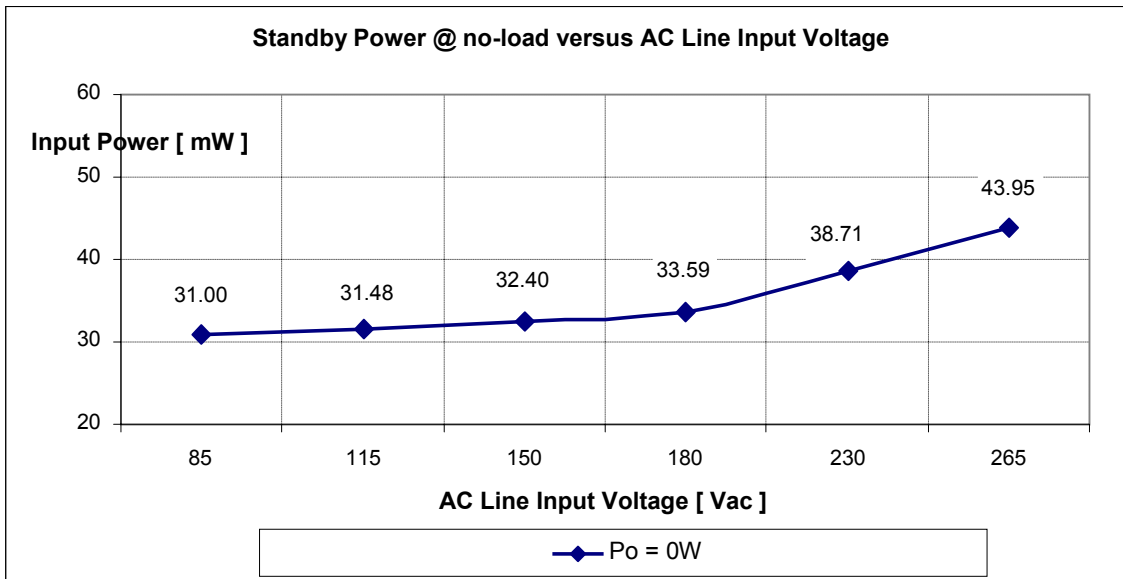

Figure 8 – Efficiency vs. Output Power @ Low and High Line



### 10.2 Input Standby Power



**Figure 9** – Input Standby Power @ no load Vs. AC Line Input Voltage (measured by Yokogawa WT210 power meter - integration mode)

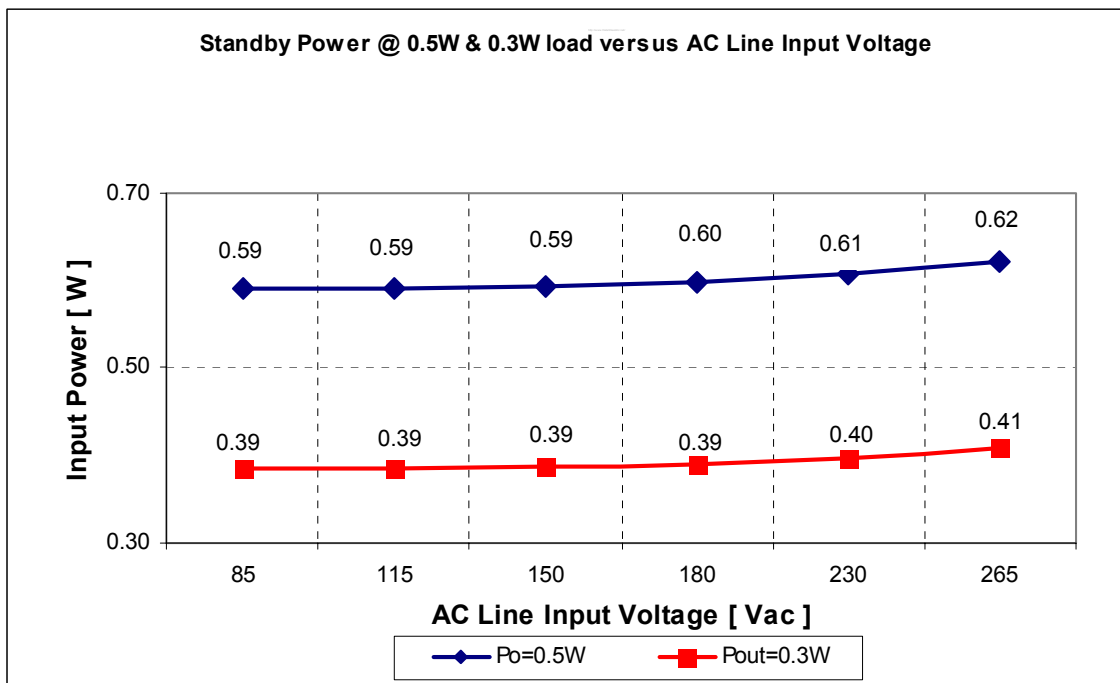

**Figure 10** – Input Standby Power @ 0.5W & 0.3W Vs. AC Line Input Voltage (measured by Yokogawa WT210 power meter - integration mode)

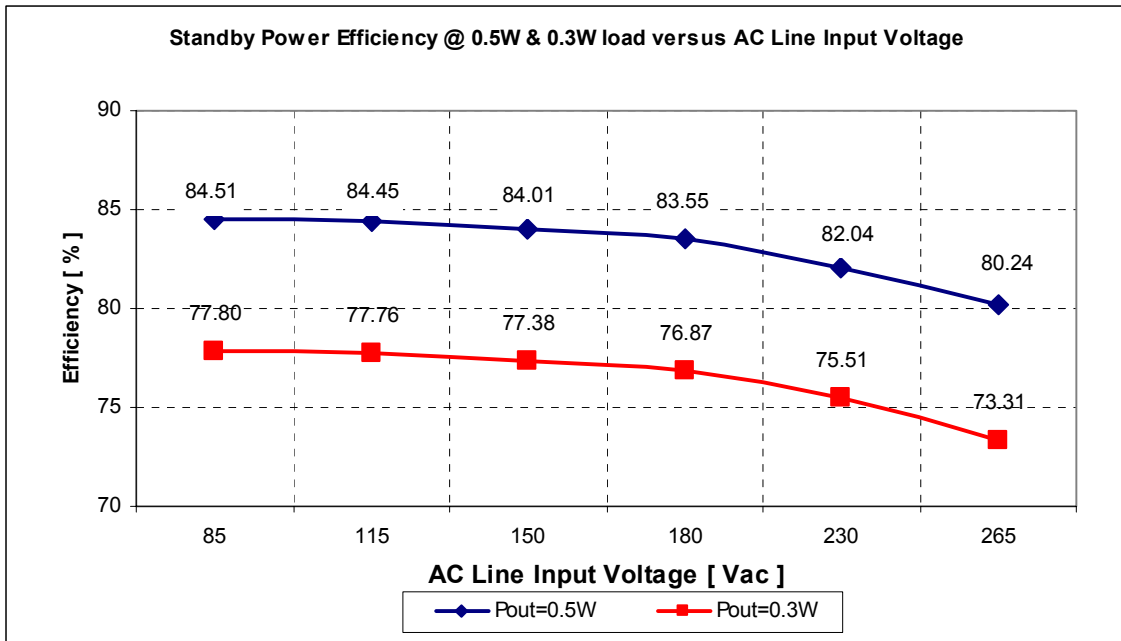

Figure 11 – Input Standby Power Efficiency @ 0.5W & 0.3W vs. AC Line Input Voltage

### 10.3 Line Regulation

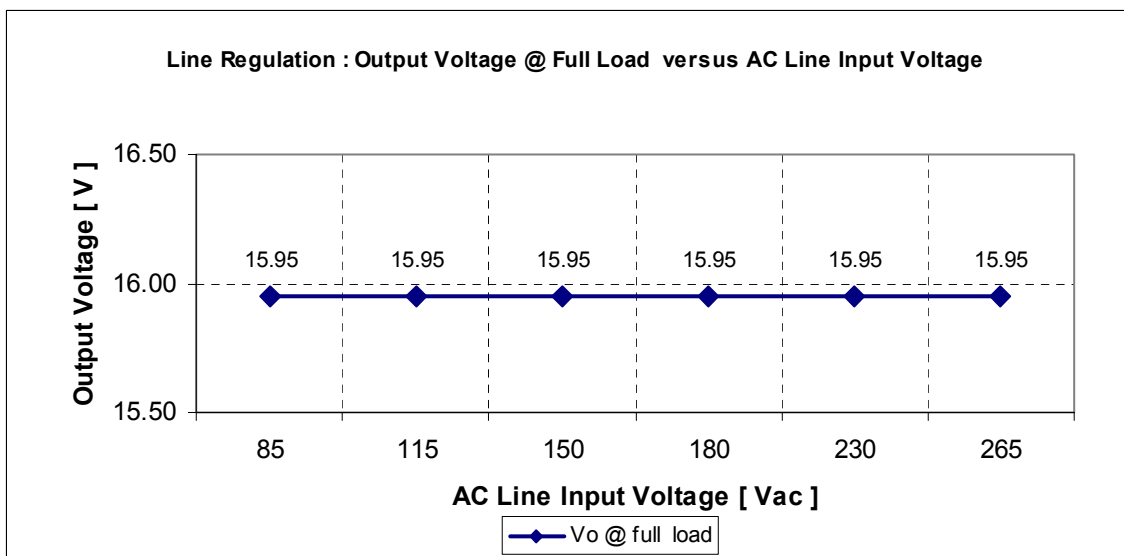

Figure 12 – Line Regulation Vo @ full load vs. AC Line Input Voltage

### 10.4 Load Regulation

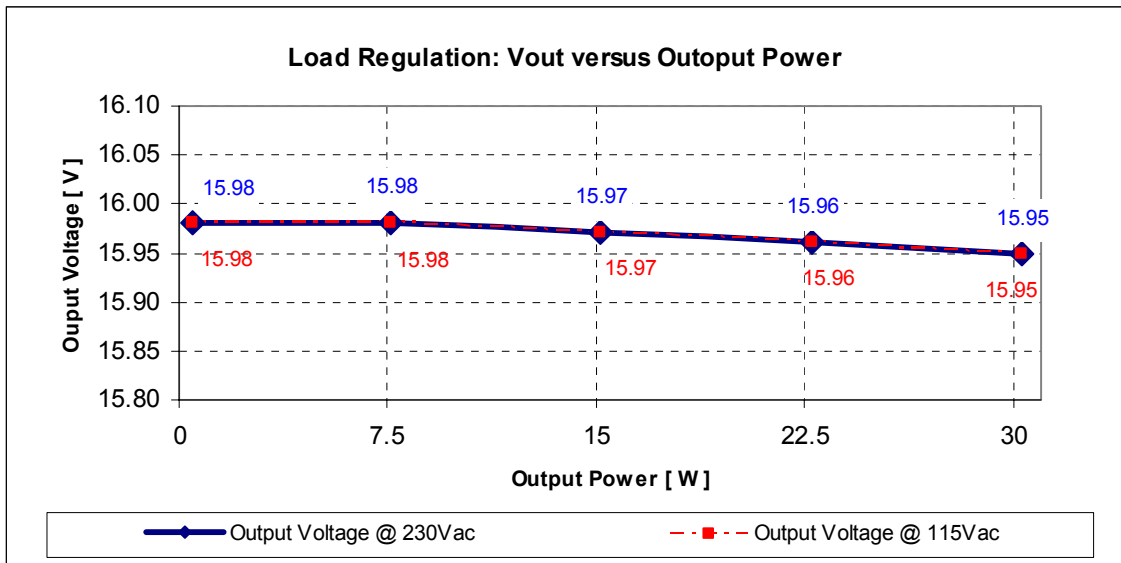

Figure 13 – Load Regulation Vout vs. Output Power

### 10.5 Max. Output Power

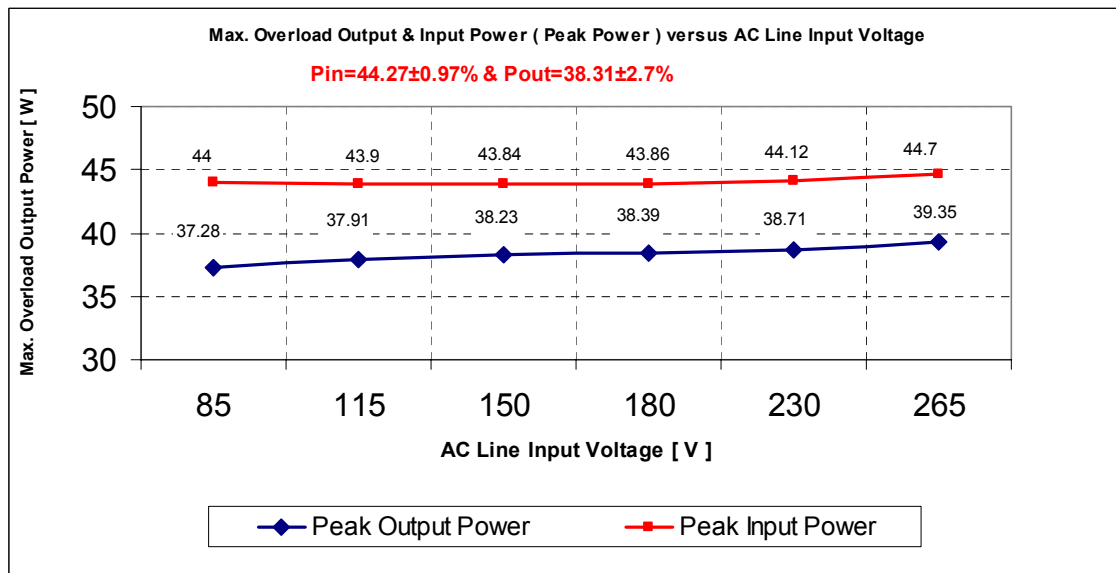

Figure 14 – Max. Output Power (before over-load protection) vs. AC Line Input Voltage

### 10.6 ESD Test

Pass\* (EN61000-4-2) Level 4: 8kV for contact discharge.

\*Add L3 and C16

### 10.7 Lightning Surge Test

Pass\* (EN61000-4-5) 4kV for line to earth

\*Add SG1 & SG2 (DSP-301N-S008)

### 10.8 Conducted EMI

The conducted EMI was measured by Schaffner (SMR4503) and followed the test standard of EN55022 class B. The demo board was set up at maximum load (30W) with input voltage of 115Vac and 230Vac.

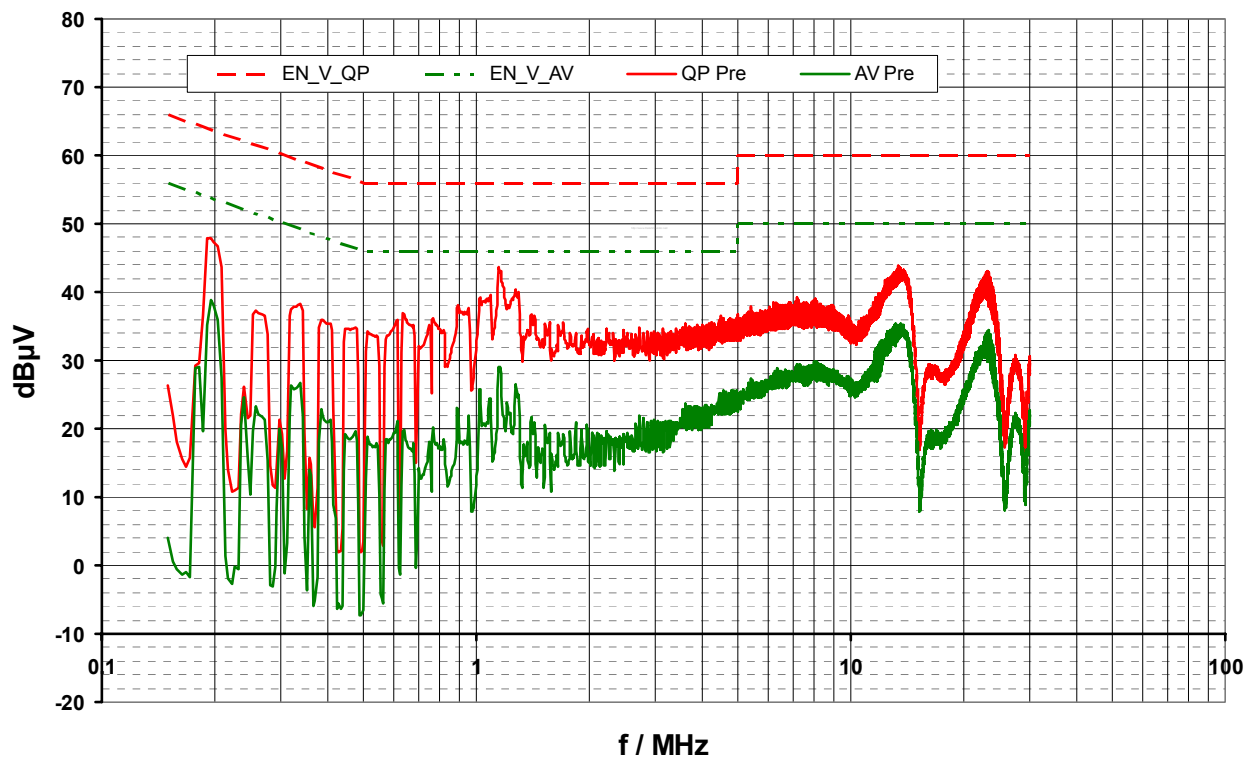

Figure 15 – Max. Load (30W) with 115 Vac (Line)

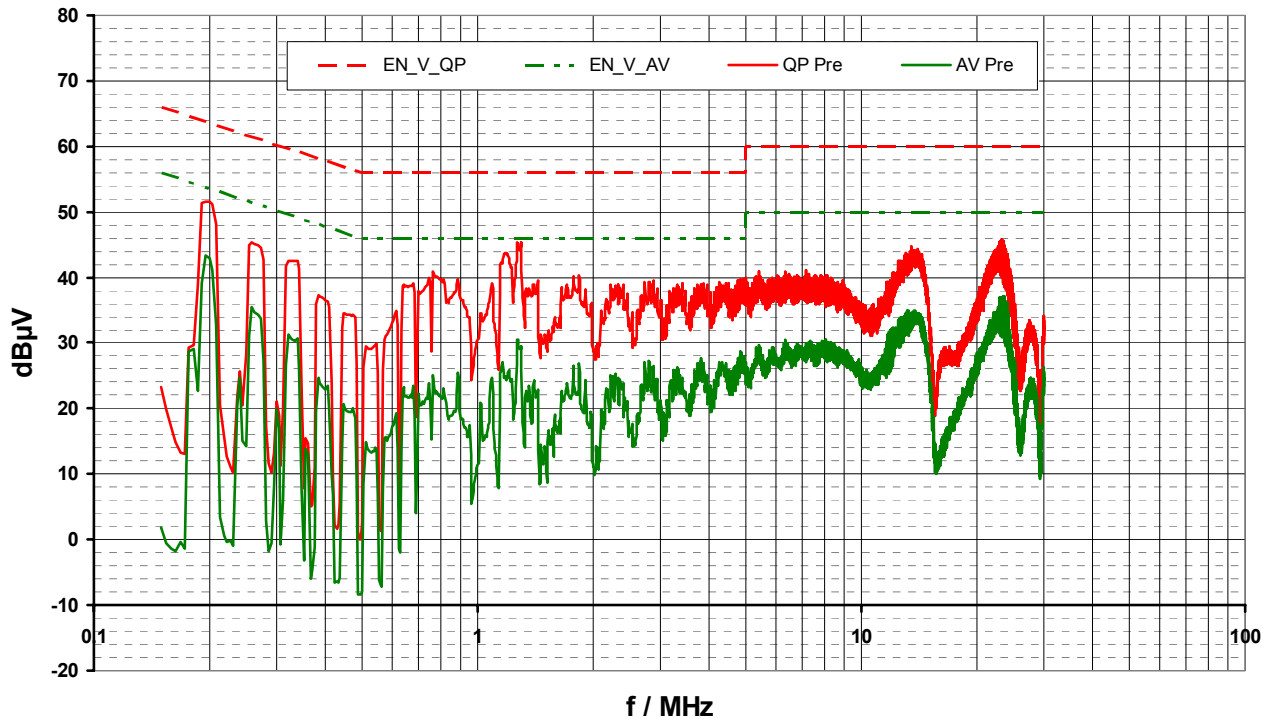
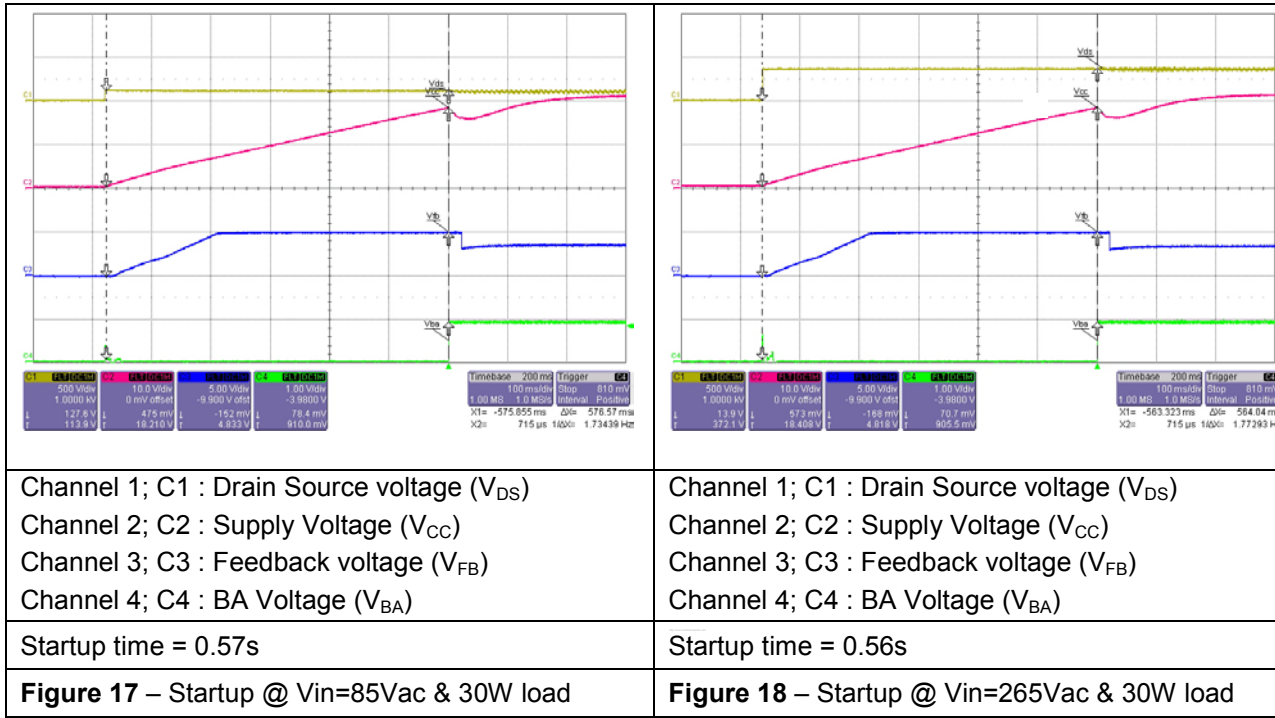

Figure 16 – Max. Load (30W) with 230 Vac (Line)

## 11 Waveforms and Scope Plots

All waveforms and scope plots were recorded with a LeCroy 6050 oscilloscope

### 11.1 Start up at low and high AC line input voltage and 30W load



### 11.2 Soft start at low and high AC line input voltage and 30W load

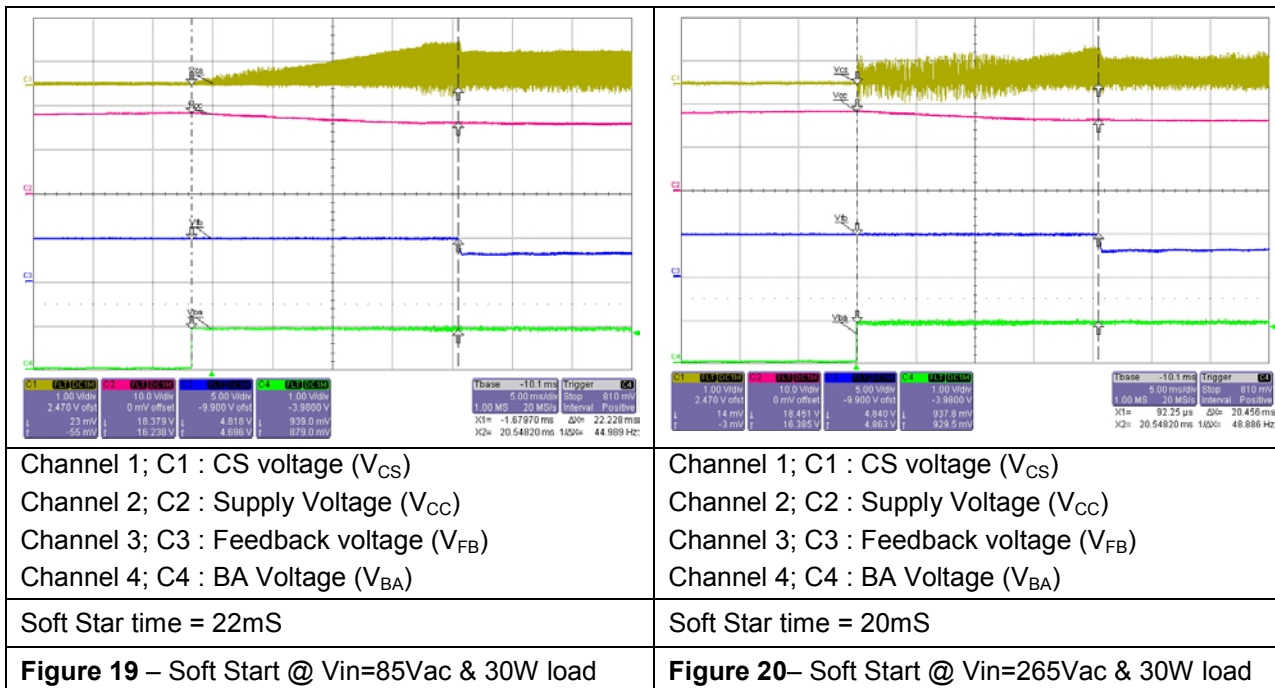

### 11.3 Frequency jittering

<p>Channel 1; C1 : Drain Source voltage (<math>V_{DS}</math>)</p>	<p>Channel 1; C1 : Drain Source voltage (<math>V_{DS}</math>)</p>
<p>Frequency changing from 63.1 kHz ~ 67.7 kHz, Jitter period is set at 4ms internally</p>	<p>Frequency changing from 63kHz ~ 67.8 kHz, Jitter period is set at 4ms internally</p>
<p><b>Figure 21</b> – Frequency change shown at <math>V_{DS}</math> @ <math>V_{in}=85V_{ac}</math> and 30W Load</p>	<p><b>Figure 22</b> – Frequency change shown at <math>V_{DS}</math> @ <math>V_{in}=265V_{ac}</math> and 30W Load</p>

### 11.4 Drain to source voltage and Current at 30W load

<p>Channel 1; C1 : Drain Current (<math>I_{DS}</math>) Channel 2; C2 : Drain Source Voltage (<math>V_{DS}</math>)</p>	<p>Channel 1; C1 : Drain Current (<math>I_{DS}</math>) Channel 2; C2 : Drain Source Voltage (<math>V_{DS}</math>)</p>
<p>Duty cycle = 43.77%</p>	<p>Duty cycle = 10.76%</p>
<p><b>Figure 23</b> – Operation @ <math>V_{in} = 85V_{ac}</math> and 30W load</p>	<p><b>Figure 24</b> – Operation @ <math>V_{in} = 265V_{ac}</math> and 30W load</p>

### 11.5 Load transient response (Load jump from 10% to 100%)

<p>Channel 1; C1 : Output Ripple Voltage (Vo) Channel 2; C2 : Output Current (Io)</p>	<p>Channel 1; C1 : Output Ripple Voltage (Vo) Channel 2; C2 : Output Current (Io)</p>
<p>Current step slew rate = 0.4A/us</p>	<p>Current step slew rate = 0.4A/us</p>
<p><b>Figure 25</b> – Load jump @ Vin=85Vac from 3W to 30W load</p>	<p><b>Figure 26</b> – Load jump @ Vin=265Vac from 3W to 30W load</p>

### 11.6 AC output ripple voltage at 30W load

<p>Channel 1; C1 : Output Ripple Voltage (Vo_ripple) Vo_ripple_pk to pk = 140mV Probe Terminal end with decoupling capacitor of 0.1uF(ceramic) &amp; 1uF(Electrolytic), 20MHz filter</p>	<p>Channel 1; C1 : Output Ripple Voltage (Vo_ripple) Vo_ripple_pk to pk = 150mV Probe Terminal end with decoupling capacitor of 0.1uF(ceramic) &amp; 1uF(Electrolytic), 20MHz filter</p>
<p><b>Figure 27</b> – AC output ripple @ Vin=85Vac and 30W load</p>	<p><b>Figure 28</b> – AC output ripple @ Vin=265Vac and 30W load</p>



11.7 Active burst mode at 0.5W load

<p>Channel 1; C1 : Drain Source Voltage (<math>V_{DS}</math>)            Channel 2; C2 : Current Sense Voltage (<math>V_{CS}</math>)            Channel 3; C3 : Feedback voltage (<math>V_{FB}</math>)</p>	<p>Channel 1; C1 : Drain Source Voltage (<math>V_{DS}</math>)            Channel 2; C2 : Current Sense Voltage (<math>V_{CS}</math>)            Channel 3; C3 : Feedback voltage (<math>V_{FB}</math>)</p>
<p>Blanking time to enter burst mode : 19.2ms</p>	<p>Blanking time to enter burst mode : 19.4ms</p>
<p><b>Figure 29</b> – Active burst mode @ <math>V_{in}=85V_{ac}</math> and step from 1.9A to 0.03A</p>	<p><b>Figure 30</b> – Active burst mode @ <math>V_{in}=265V_{ac}</math> and step from 1.9A to 0.03A</p>
<p>Channel 4; C4 : Output Voltage (<math>V_o</math>)</p>	<p>Channel 4; C4 : Output Voltage (<math>V_o</math>)</p>
<p>Output ripple : app. 40mV</p>	<p>Output ripple : app. 40mV</p>
<p><b>Figure 31</b> – Output ripple at active burst mode @ <math>V_{in}=85V_{ac}</math> and 0.5W load</p>	<p><b>Figure 32</b> – Output ripple at active burst mode @ <math>V_{in}=265V_{ac}</math> and 0.5W load</p>

### 11.8 Vcc overvoltage protection – Auto Restart

<p>Channel 1; C1 : Drain Source voltage (<math>V_{DS}</math>)            Channel 2; C2 : Supply voltage (<math>V_{CC}</math>)            Channel 3; C3 : Feedback Voltage (<math>V_{FB}</math>)            Channel 4; C4 : BA voltage (<math>V_{BA}</math>)</p>	<p>Channel 1; C1 : Drain Source voltage (<math>V_{DS}</math>)            Channel 2; C2 : Supply voltage (<math>V_{CC}</math>)            Channel 3; C3 : Feedback Voltage (<math>V_{FB}</math>)            Channel 4; C4 : BA voltage (<math>V_{BA}</math>)</p>
<p>System enters auto restart mode when <math>V_{CC} &gt; 20.5V</math> &amp; <math>V_{FB} &gt; 4.0V</math> during soft start period</p>	<p>System enters auto restart mode when <math>V_{CC} &gt; 20.5V</math> &amp; <math>V_{FB} &gt; 4.0V</math> during soft start period</p>
<p><b>Figure 33</b> – Vcc overvoltage protection @ <math>V_{in}=85V_{ac}</math>; R10 disconnected before system start up with no load</p>	<p><b>Figure 34</b> – Vcc overvoltage protection @ <math>V_{in}=265V_{ac}</math>; R10 disconnected before system start up with no load</p>
<p>Channel 1; C1 : Drain Source voltage (<math>V_{DS}</math>)            Channel 2; C2 : Supply voltage (<math>V_{CC}</math>)            Channel 3; C3 : Feedback Voltage (<math>V_{FB}</math>)            Channel 4; C4 : BA voltage (<math>V_{BA}</math>)</p>	<p>Channel 1; C1 : Drain Source voltage (<math>V_{DS}</math>)            Channel 2; C2 : Supply voltage (<math>V_{CC}</math>)            Channel 3; C3 : Feedback Voltage (<math>V_{FB}</math>)            Channel 4; C4 : BA voltage (<math>V_{BA}</math>)</p>
<p>System enters auto restart mode when <math>V_{CC} &gt; 25.5V</math></p>	<p>System enters auto restart mode when <math>V_{CC} &gt; 25.5V</math></p>
<p><b>Figure 35</b> – Vcc overvoltage protection @ <math>V_{in}=85V_{ac}</math>; R10 disconnected under light load</p>	<p><b>Figure 36</b> – Vcc overvoltage protection @ <math>V_{in}=265V_{ac}</math>; R10 disconnected under light load</p>

### 11.9 Over load protection – Auto Restart

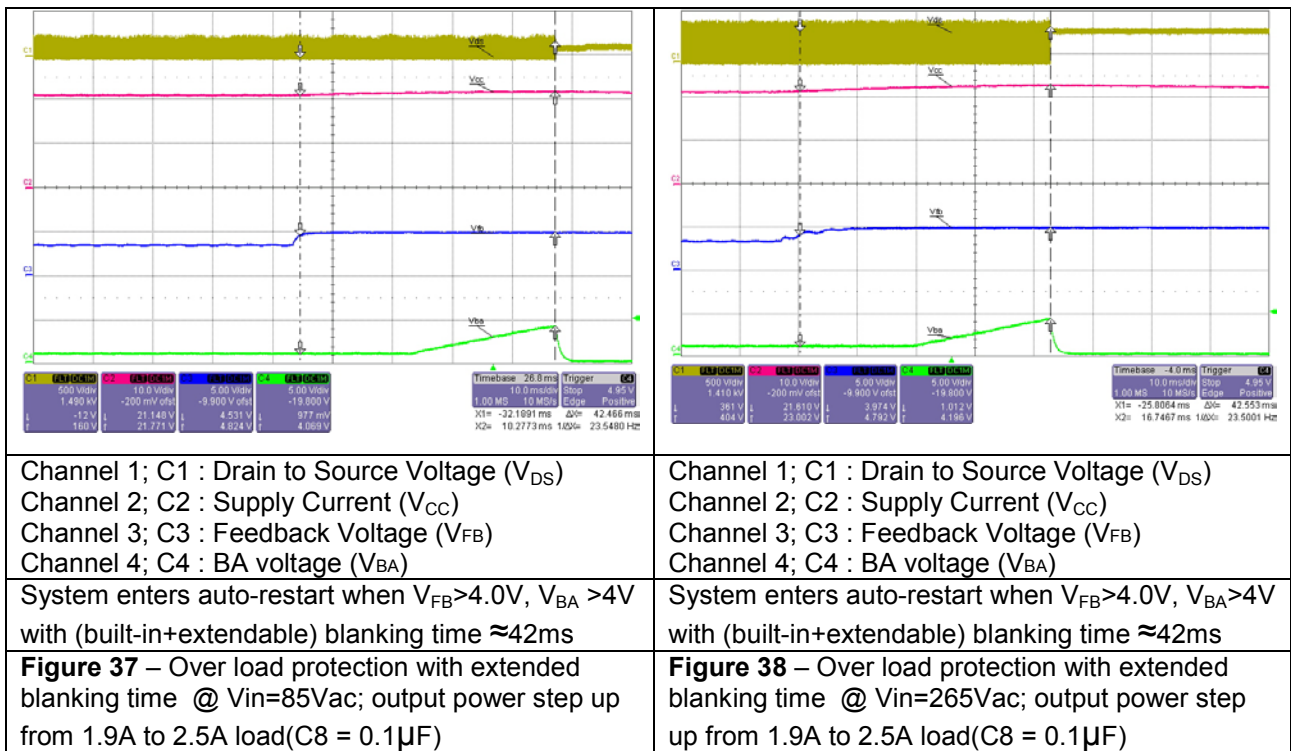

### 11.10 Open loop protection – Auto Restart

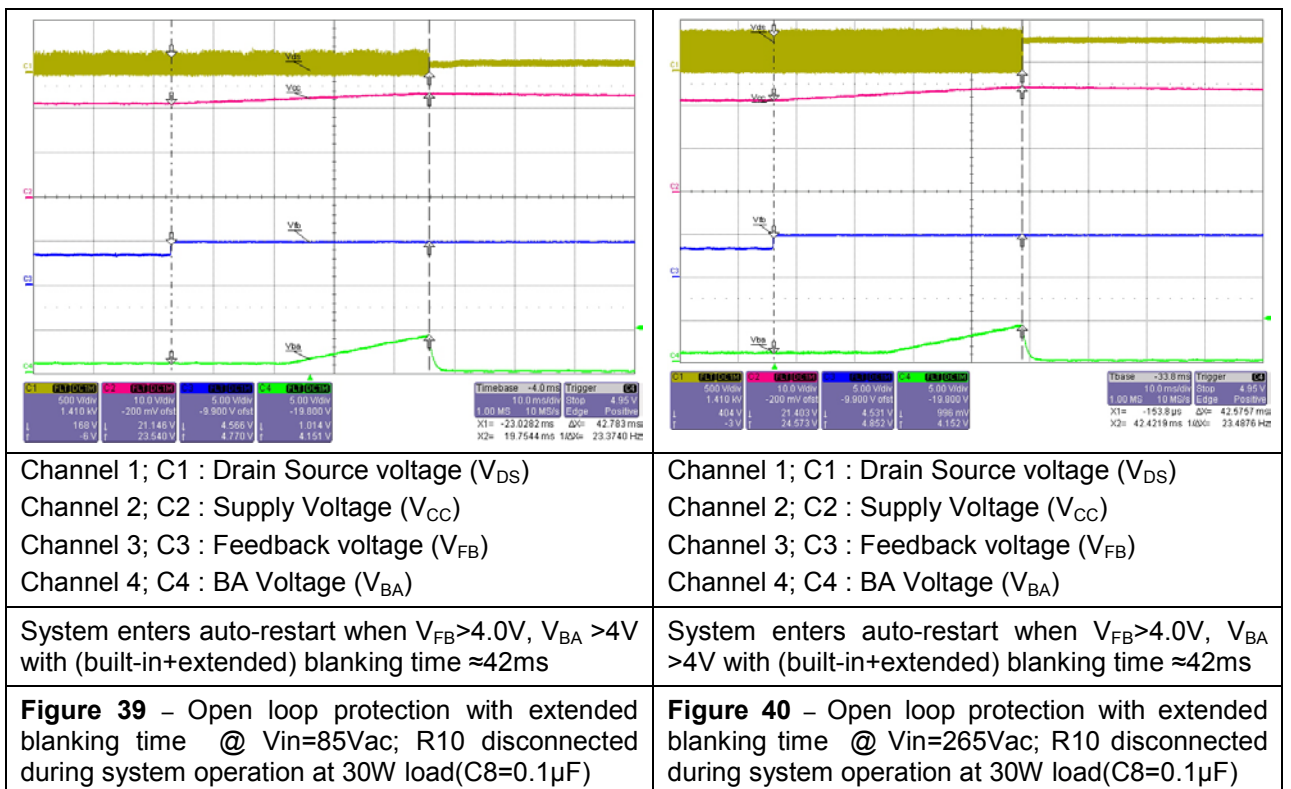

### 11.11 Vcc under voltage/Short optocoupler protection– Auto Restart

<p>Channel 1; C1 : Drain Source voltage (<math>V_{DS}</math>)          Channel 2; C2 : Supply Voltage (<math>V_{CC}</math>)          Channel 3; C3 : Feedback voltage (<math>V_{FB}</math>)          Channel 4; C4 : BA Voltage (<math>V_{BA}</math>)</p>	<p>Channel 1; C1 : Drain Source voltage (<math>V_{DS}</math>)          Channel 2; C2 : Supply Voltage (<math>V_{CC}</math>)          Channel 3; C3 : Feedback voltage (<math>V_{FB}</math>)          Channel 4; C4 : BA Voltage (<math>V_{BA}</math>)</p>
<p>System enters Auto Restart mode when <math>V_{CC} &lt; 10.5V</math></p>	<p>System enters Auto Restart mode when <math>V_{CC} &lt; 10.5V</math></p>
<p><b>Figure 41</b> – Short optocoupler protection @ <math>V_{in}=85V_{ac}</math>; Short the transistor of optocoupler during system operation.</p>	<p><b>Figure 42</b> – Short optocoupler protection @ <math>V_{in}=265V_{ac}</math>; Short the transistor of optocoupler during system operation.</p>

### 11.12 External auto restart enable

<p>Channel 1; C1 : Drain Source voltage (<math>V_{DS}</math>)          Channel 2; C2 : Supply Voltage (<math>V_{CC}</math>)          Channel 3; C3 : Feedback voltage (<math>V_{FB}</math>)          Channel 4; C4 : BA Voltage (<math>V_{BA}</math>)</p>	<p>Channel 1; C1 : Drain Source voltage (<math>V_{DS}</math>)          Channel 2; C2 : Supply Voltage (<math>V_{CC}</math>)          Channel 3; C3 : Feedback voltage (<math>V_{FB}</math>)          Channel 4; C4 : BA Voltage (<math>V_{BA}</math>)</p>
<p>System enters auto restart mode when <math>V_{ba} &lt; 0.33V</math></p>	<p>System enters auto restart mode when <math>V_{ba} &lt; 0.33V</math></p>
<p><b>Figure 43</b> – Auto restart enable by trigger BA pin @ <math>V_{in}=85V_{ac}</math>; Short BA pin during system operation</p>	<p><b>Figure 44</b>– Auto restart enable by trigger BA pin @ <math>V_{in}=265V_{ac}</math>; Short BA pin during system operation</p>

## 12 Appendix

### 12.1 Slope compensation for CCM operation

This demo board is designed in Discontinuous Conduction Mode ( DCM ) operation. If the application is designed in Continuous Conduction Mode ( CCM ) operation where the maximum duty cycle exceeds the 50% threshold, it needs to add the slope compensation network. Otherwise, the circuitry will be unstable. In this case, three more components ( 2 ceramic capacitors C17 / C18 and one resistor R19) is needed to add as shown in the circuit diagram below.

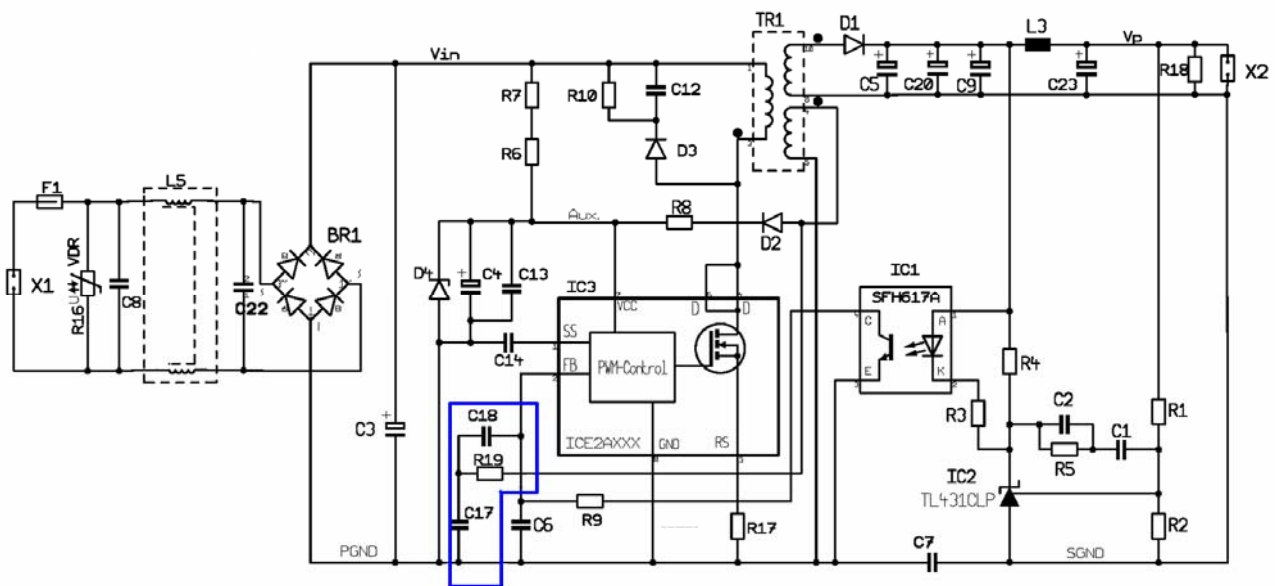

**Figure 41** – Circuit Diagram Switch Mode Power Supply with Slope Compensation

More information regarding how to calculate the additional components, see application note AN\_SMPS\_ICE2xXXX – available on the internet: [www.infineon.com](http://www.infineon.com) (directory : [Home](#) > [Power Semiconductors](#) > [Integrated Power ICs](#) > [CoolSET® F2](#))

## 13 References

- [1] Infineon Technologies, Datasheet “CoolSET®-F3R ICE3BR0665J Off-Line SMPS Current Mode Controller with integrated 650V CoolMOS® and Startup cell( Frequency Jitter Mode ) in DIP-8”
- [2] Eric Kok Siu Kam, Kyaw Zin Min, Infineon Technologies, Application Note “ICE3BRxx65J CoolSET® - F3R (DIP-8) new Jitter version Design Guide”
- [3] Harald Zoellinger, Rainer Kling, Infineon Technologies, Application Note “AN-SMPS-ICE2xXXX-1, CoolSET® ICE2xXXXX for Off-Line Switching Mode Power supply (SMPS )”