



### FEATURES

- ARC enabled LRA automatic resonance detection and magnitude control
- Agile pattern generator enabling HD haptic effects
- Fast start and sharp braking
- PWM and I<sup>2</sup>C drive modes
- Low latency response (LLR) drive mode
- Compatible with Immersion TS3000 and Immersion TS4000
- 8-bit DAC with programmable, bidirectional output current source capability
- 2-wire (I<sup>2</sup>C-compatible) 1.8 V serial interface
- Short-circuit protection
- Undervoltage protection
- Pin-selectable I<sup>2</sup>C address feature
- Available in a 5 × 3 array WLCSP package

### APPLICATIONS

- Haptics applications
- Linear resonant actuators
- Eccentric rotating mass actuators
- Mobile phones
- Portable media players
- Portable navigation devices
- Tablet PCs

### GENERAL DESCRIPTION

The **ADUX1001i** is a high efficiency linear resonant actuator (LRA) controller that uses the Analog Devices, Inc., proprietary Actuator Response Control™ (ARC™) technology. The **ADUX1001i** control algorithm detects LRA resonant frequency and provides closed-loop control of drive frequency and magnitude, ensuring compelling, reliable, and repeatable haptic effects for all portable, gaming, and handheld applications. The **ADUX1001i** features an 8-bit digital-to-analog converter (DAC) that has programmable, bi-directional output current capability. The hardware shutdown mode ensures low power operation over a full 2.3 V to 4.8 V supply range, making it ideally suited for portable mobile device haptic applications.

The **ADUX1001i** is compatible with Immersion TS3000 and Immersion TS4000 engines.

The **ADUX1001i** features three interface options ensuring that the **ADUX1001i** can be used in existing haptic implementations as well as in new low latency haptic implementations. The operating modes of the controller are invoked by the **ADUX1001i** using a PWM- and/or an I<sup>2</sup>C-compatible interface. The I<sup>2</sup>C 7-bit address for the **ADUX1001i** is programmable using two external pins.

### FUNCTIONAL BLOCK DIAGRAM

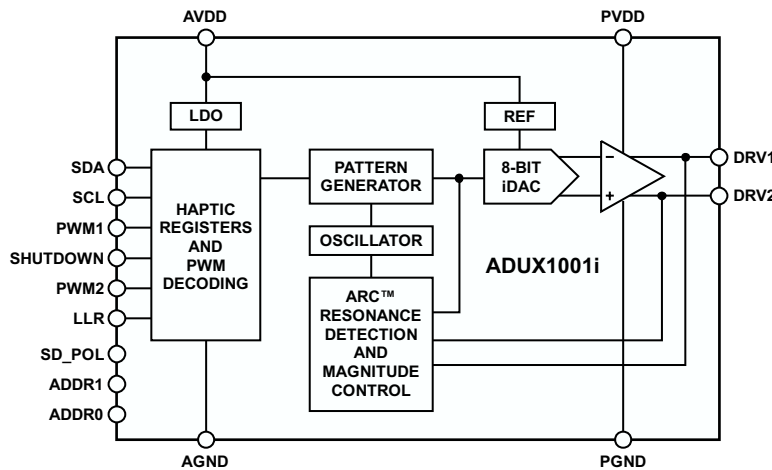

Figure 1.

For more information about the **ADUX1001i**, email: [haptics@analog.com](mailto:haptics@analog.com).

#### Rev. Sp0

Information furnished by Analog Devices is believed to be accurate and reliable. However, no responsibility is assumed by Analog Devices for its use, nor for any infringements of patents or other rights of third parties that may result from its use. Specifications subject to change without notice. No license is granted by implication or otherwise under any patent or patent rights of Analog Devices. Trademarks and registered trademarks are the property of their respective owners.

**NOTES**