

# SAW Resonators

**SURFACE  
ACOUSTIC  
WAVE  
RESONATORS**

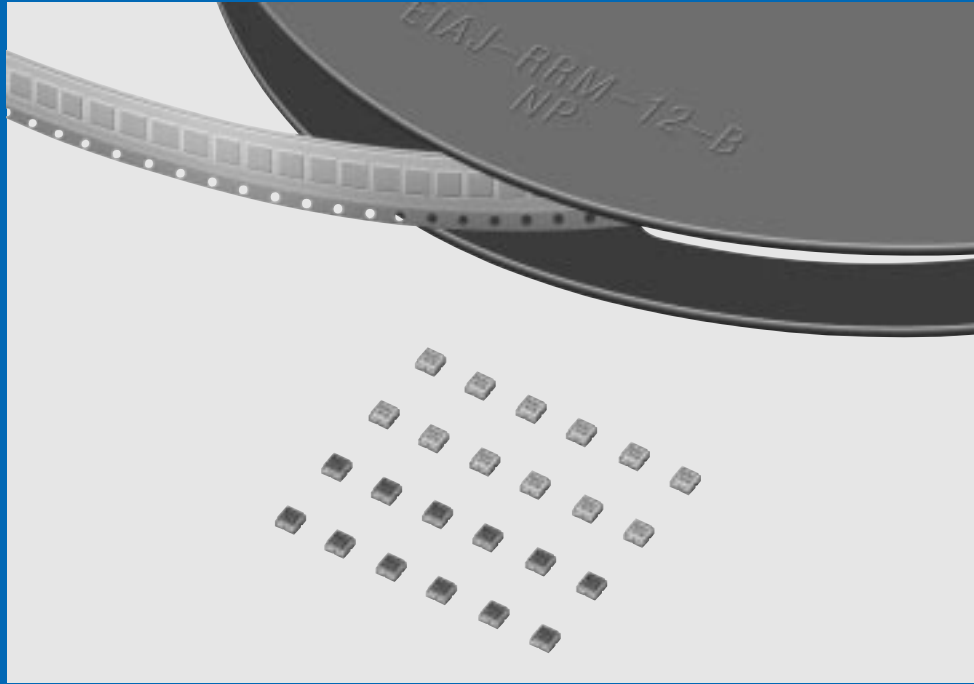

**muRata** *Innovator  
in Electronics*

Murata  
Manufacturing Co., Ltd.

Cat.No.P36E

# CONTENTS

<b>Part Numbering</b>	2
<b>Applications and Data of SAW Resonator</b>	3
<b>SARCC Series</b>	5
● Oscillation Circuit	7
● Actual measurements of SAW Oscillator	9
● Keyless Entry System	15
● Packaging/Notice	16

● **Part Numbering** (The structure of the "Global Part Numbers" that have been adopted since June 2001 and the meaning of each code are described herein.)  
 If you have any questions about details, inquire at your usual Murata sales office or distributor.

**SAW Resonators**

(Global Part Number) 

SA	R	CC	433M92	B	X	M	0	R05
①	②	③	④	⑤	⑥	⑦	⑧	⑨

① Product ID

Product ID	
<b>SA</b>	SAW

② Function

Code	Function
<b>R</b>	Resonator

③ Structure/Size

Code	Structure/Size
<b>CC</b>	Package (SC33 package)

④ Resonant Frequency

Expressed by six-digit alphanumerics. The unit is in hertz (Hz). A decimal point is expressed by the capital letter "M".

⑤ Design

Code	Design
<b>B</b>	1 port

⑥ Board

Code	Board
<b>X</b>	Crystal

⑦ Resonant Frequency Tolerance

Code	Resonant Frequency Tolerance
<b>L</b>	±50kHz
<b>M</b>	±75kHz
<b>P</b>	±100kHz

⑧ Customer Code

Expressed by a figure.

⑨ Packaging

Code	Packaging
<b>R12</b>	2000pcs. /ø178mm Reel
<b>R05</b>	5000pcs. /ø330mm Reel

# Applications and Data of SAW Resonator

## ■ Application

SAW RESONATOR has generally 2 types of 1-port type and 2-port type.

1-port SAW RESONATOR is basically a 2 terminal device and its application is similar to that of quartz bulk wave resonator or ceramic resonator. Most of the application circuit is Colpitts or similar type that can be made with low cost. 1-port SAW RESONATOR is also applicable to VCO (Voltage Controlled Oscillator) application.

2-port SAW RESONATOR is a kind of very narrow, low loss band-pass filter. Oscillation circuit is mostly like a RF amplifier with feedback loop.

SARCC series is 1-port SAW RESONATOR. Later application data is oscillation circuit by 1-port SAW RESONATOR.

## ■ Basic structure of 1-port SAW RESONATOR

1-port SAW RESONATOR has one IDT (Inter Digital Transducer), which generates and receives SAW, and two grating reflectors, which reflect SAW and generate a standing wave between the two reflectors. IDT and reflectors are fabricated on quartz crystal substrate by photolithographic process. Cut angle of the substrate shall be selected carefully. SAW RESONATOR chip is encapsulated in a ceramic package.

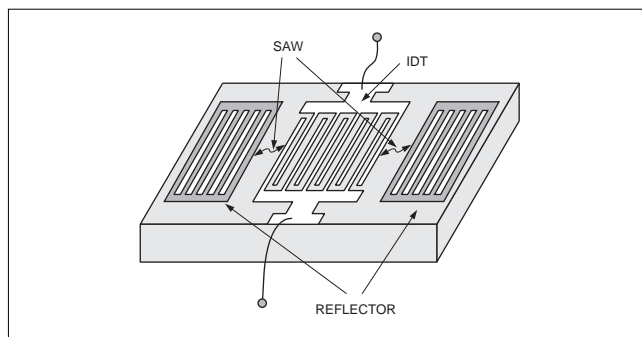

## ■ Test Circuit

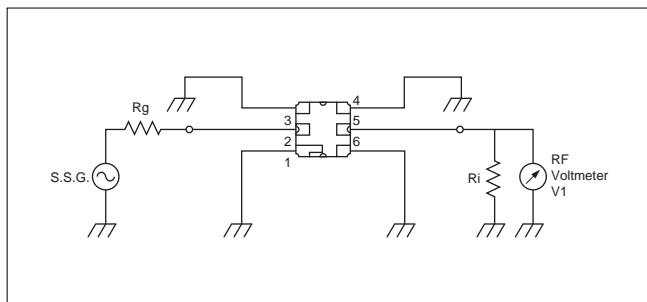

## ■ Transmission Characteristics of 1-port SAW RESONATOR

SARCC315M00BXM0

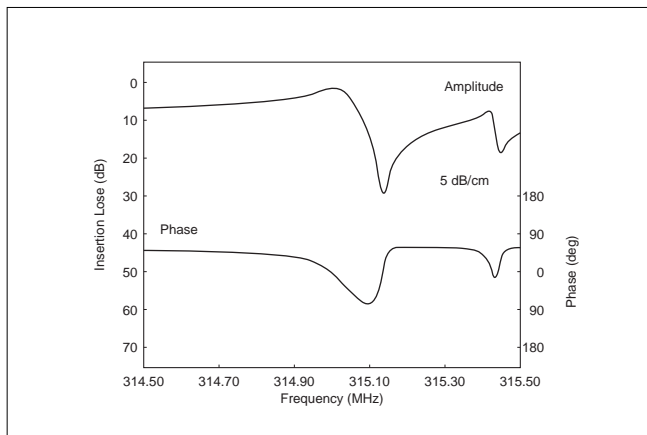

SARCC433M92BXM0

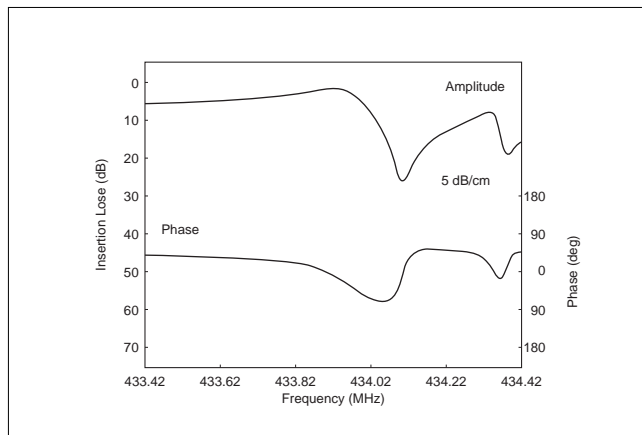

Continued on the following page.

## Applications and Data of SAW Resonator

☐ Continued from the preceding page.

### ■ Temperature Characteristics of 1-port SAW RESONATOR

SARCC315M00BXM0

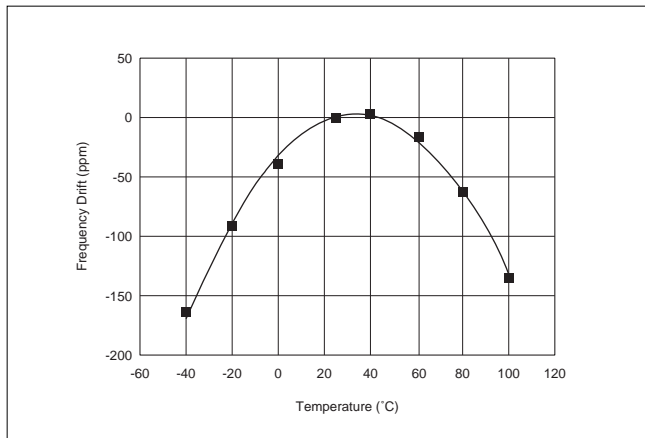

SARCC433M92BXM0

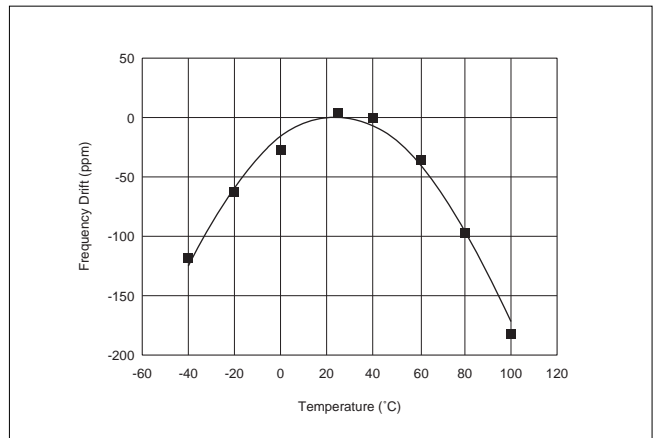

# SAW Resonators



## SARCC Series

SAW Resonator utilizes Surface acoustic Wave, and is able to be applied to high frequency circuit where conventional crystal, ceramic resonators are not available, as SAW Resonator oscillates stably with its fundamental mode over frequency range from 50 MHz to around 1 GHz.

Murata SAW Resonator - SARCC series - has high stability, good temperature characteristics provided by quartz crystal substrate and is developed with SAW technology accumulated for SAW filters through Murata's long experience.

SAW Resonator can be applied to many types of high frequency devices including RF remote controls, CATV FSK demodulators and CATV 2nd local oscillators.

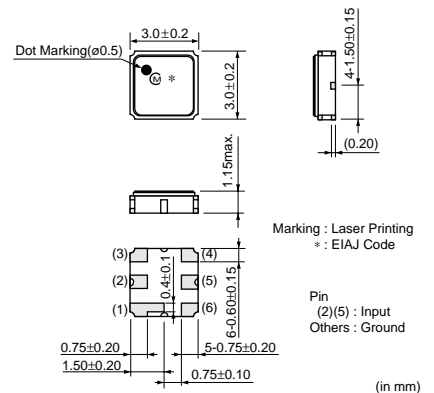

### ■ Features

- High Oscillation Frequency Stability**  
 Both initial tolerance and temperature coefficient of oscillating frequency of SAW Resonator are between quartz bulk resonator's and LC's / RC's. Temperature coefficient of oscillating frequency for quartz crystal :  
 $10^{**}-6/\text{degree C}$ , LC :  $10^{**}-3-10^{**}-4/\text{degree C}$ , while SAW Resonator :  $5 \times 10^{**}-6/\text{degree C}$ .  
 (The number following \*\* means multiplier.)
- Adjustment Free**  
 As SAW Resonator utilizes mechanical vibration of piezoelectric material, while LC/RC utilizes electrical resonance, oscillator using SAW Resonator is stable against peripheral circuit or supply voltage fluctuation, and is basically free from adjustment.
- Simple/Low Cost Circuit by Fundamental Oscillation**  
 Multiplying circuit necessary for quartz bulk wave resonator is not required as SAW Resonator oscillates with its fundamental mode over the frequency range of 50 MHz to 1 GHz. Therefore, oscillation circuit is simple and low cost.
- Quartz Crystal Substrate**  
 SARCC series realizes better temperature characteristics, higher stability against peripheral circuit, by utilizing quartz crystal substrate, compared to SAW Resonators with other materials.
- Small Size Package**  
 SARCC series use small size ceramic package with  $3.0 \times 3.0 \times 1.15$  mm. This is good for high density mount.
- They can be applied Corpitts Oscillator circuit.
- Components do not contain lead.

Part Number	Resonant Loss (dB)	Resonant Frequency (MHz)	Parallel Capacitance (at 1MHz) (pF)
SARCC304M30BXL0	2.2 max.	304.300	2.4
SARCC304M30BXM0	2.2 max.	304.300	2.4
SARCC304M30BXP0	2.2 max.	304.300	2.4
SARCC315M00BXL0	2.2 max.	315.000	2.4
SARCC315M00BXM0	2.2 max.	315.000	2.4
SARCC315M00BXP0	2.2 max.	315.000	2.4
SARCC423M22BXL0	2.5 max.	423.220	2.1
SARCC423M22BXM0	2.5 max.	423.220	2.1
SARCC423M22BXP0	2.5 max.	423.220	2.1
SARCC433M87BXL0	2.5 max.	433.870	2.1
SARCC433M87BXM0	2.5 max.	433.870	2.1
SARCC433M87BXP0	2.5 max.	433.870	2.1
SARCC433M92BXL0	2.5 max.	433.920	2.1
SARCC433M92BXM0	2.5 max.	433.920	2.1
SARCC433M92BXP0	2.5 max.	433.920	2.1
SARCC434M15BXL0	2.5 max.	434.150	2.1
SARCC434M15BXM0	2.5 max.	434.150	2.1
SARCC434M15BXP0	2.5 max.	434.150	2.1

Operating Temperature Range: -40 to +85 degree C, Storage Temperature Range: -40 to +85 degree C.

### ■ Equivalent Circuit

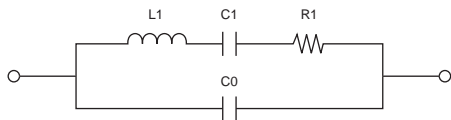

Part Number	L1 (μH)	C1 (pF)	R1 (Ω)	C0 (pF)
SARCC304M30BX_0	164.495	0.001663	22.0	2.37
SARCC315M00BX_0	159.331	0.001602	22.0	2.25
SARCC423M22BX_0	110.088	0.001284	22.2	2.00
SARCC433M87BX_0	92.747	0.001451	20.2	2.00
SARCC433M92BX_0	96.529	0.001394	22.1	2.112
SARCC434M15BX_0	95.288	0.00141	20.0	1.97

### ■ Recommended Land Pattern

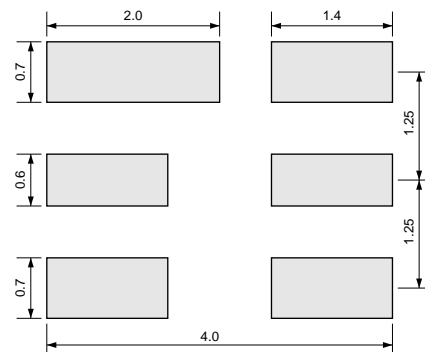

(in mm)

## Oscillation Circuit

### ■ Theory of Oscillation Circuit

Oscillation circuits using LC or quartz crystal are called 'Feedback Oscillators'. Feedback oscillator consists of an amplifier and a feedback circuit.

The circuit oscillates, with no input signal applied from outside of the oscillator, when feedback signal from the output of the amplifier has the same amplitude and phase to the input signal. The conditions required to the feedback to enable oscillation are as follows;

$$\text{Amplitude : } G = \alpha + \beta \geq 0 \text{ [dB]}$$

$$\text{Phase : } \theta = \theta_1 + \theta_2 = 360 \times n \text{ [degree]}$$

(n: Natural number)

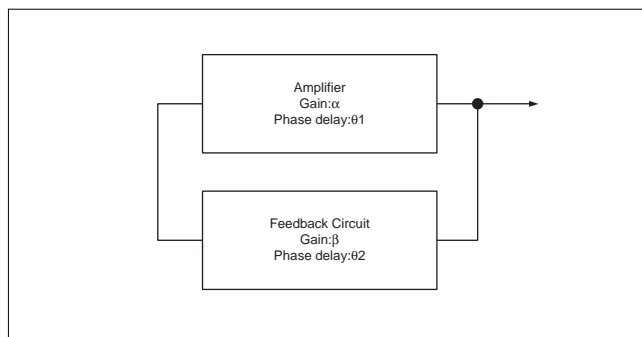

1-port SAW RESONATOR is a kind of two terminal resonant device utilizing piezoelectricity, like quartz crystal bulk wave resonator or ceramic resonator. The equivalent circuit of 1-port SAW RESONATOR is same to that of quartz or ceramic resonator, and therefore, impedance characteristics of SAW RESONATOR is as shown in Fig.1.

1. Fig. 1 Impedance Characteristics of 1-port SAW RESONATOR

SARCC315M00BXM0

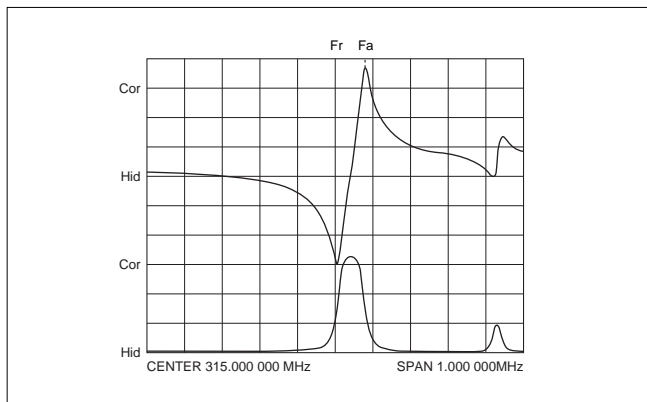

SARCC433M92BXM0

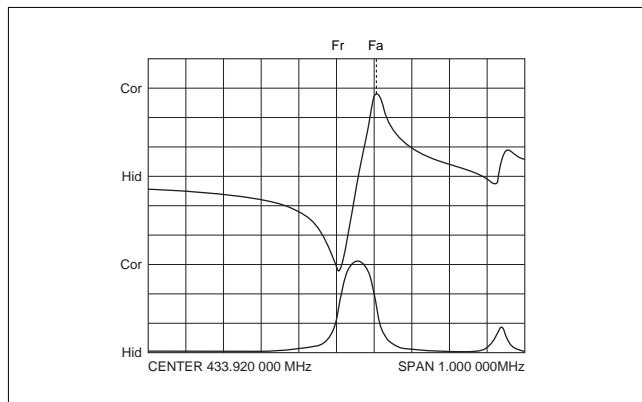

### 2. Basic Structure of Corpitts Oscillator

Colpitts is one of the popular oscillation circuits. Basic structure of Colpitts oscillator is as shown in Fig.2. The oscillating frequency is approximately same to resonant frequency of L, CL1 and CL2.

$$f_{osc} = 1 / (2 \pi ( L \times CL1 \times CL2 / ( CL1 + CL2 ) )^{1/2})$$

Fig. 2. Corpitts Oscillator Circuit.

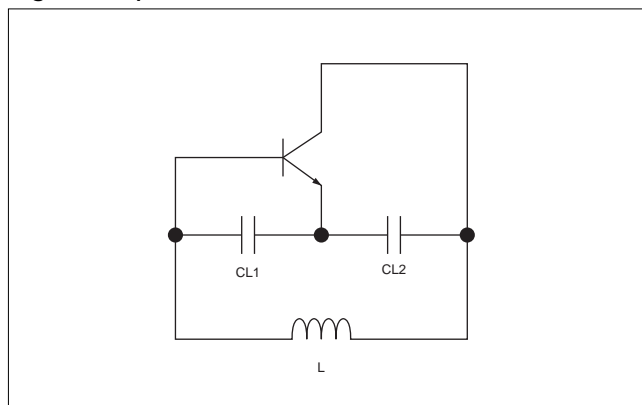

Continued on the following page. ↗



## Oscillation Circuit

☐ Continued from the preceding page.

### 3. Example of 1-port SAW Oscillator

In the case of an oscillation circuit using piezo resonator, the inductor in Fig.2 can be replaced by the resonator because its impedance is inductive between  $f_r$  (impedance minimum) and  $f_a$  (impedance maximum) as shown in Fig.1.

Fig.3 shows an example of oscillation circuit using 1-port SAW RESONATOR.  $R_{b1}$  and  $R_{b2}$  are for DC bias.  $R_e$  is a load impedance.  $C_d$  is for power line de-coupling.  $CL1$  and  $CL2$  are load capacitance to satisfy oscillation conditions. Values of  $CL1$  and  $CL2$  must be evaluated to get desired oscillating frequency.

Transistor shall be a high frequency type -  $f_T$  a few GHz or more.

SMT type transistor, resistor, capacitor are recommended for application more than 100 MHz due to the inductance of the lead terminals.

Fig. 3. 1-port SAW Oscillator Circuit

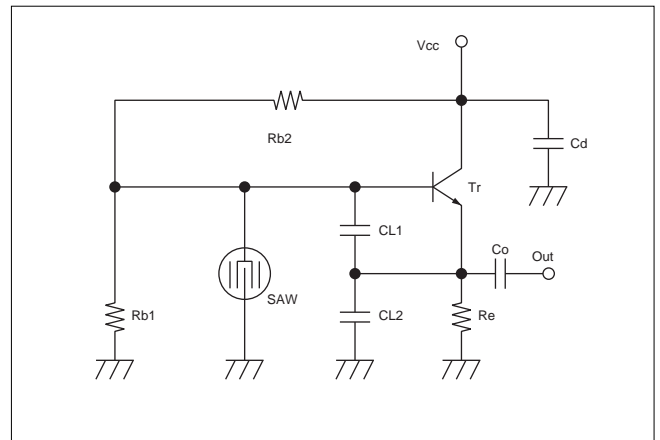

## Actual measurements of SAW Oscillator

### ■ 315 MHz 1-port SAW Oscillator

Fig.4 shows an example of oscillator with 1-port SAW RESONATOR. Here, transistor is 2SC4228(NEC), SAW RESONATOR is SARCC315M00BXL0 (315.00 MHz resonator).

Supply voltage ( $V_{cc}$ ) characteristics and temperature characteristics are shown in Fig.6. CL1, CL2, Co and Re characteristics are shown in Fig. 7 ti Fig. 10.

Tr: 2SC4228

SAW: SARCC315M00BXL0

Rb1=Rb2=2k $\Omega$

Re=160 $\Omega$

CL1=12pF GRM18821CH120JA01B

CL2=8pF GRM1882C2D8RDV01B

Co=2pF GRM1884C1H2R0CZ01B

Fig. 4 Oscillator Circuit

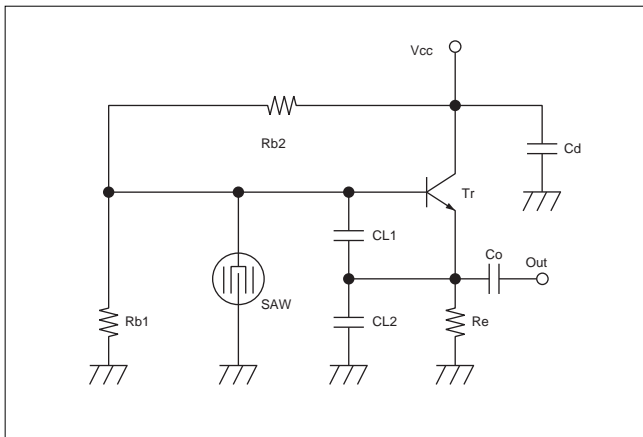
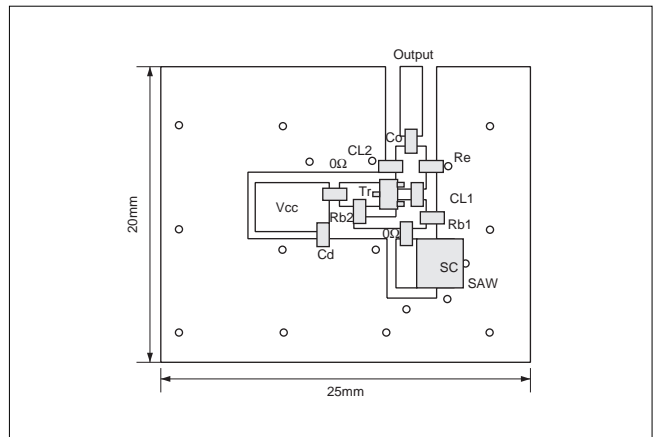
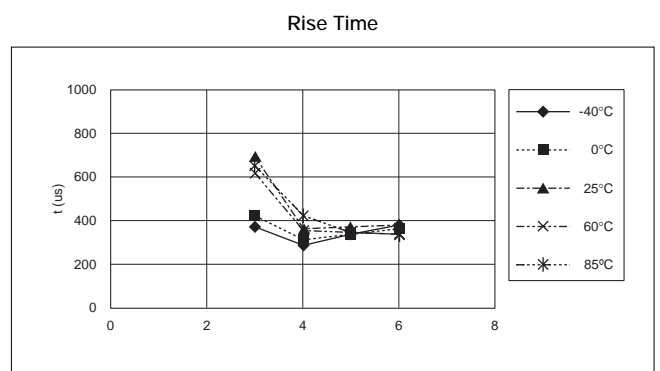
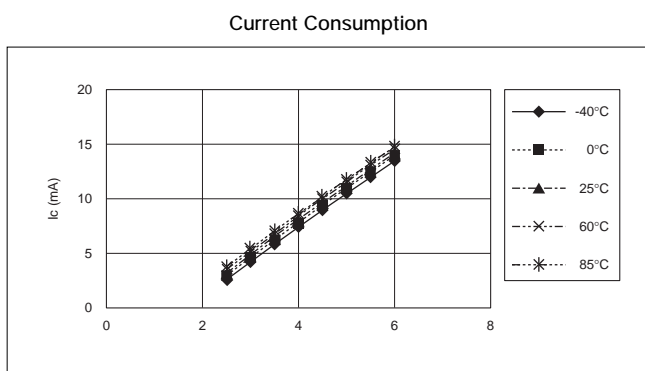
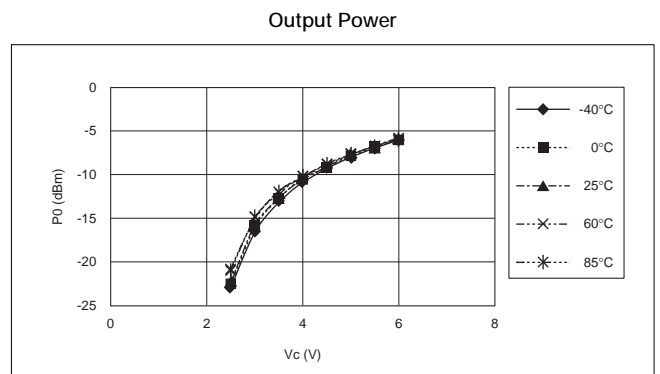
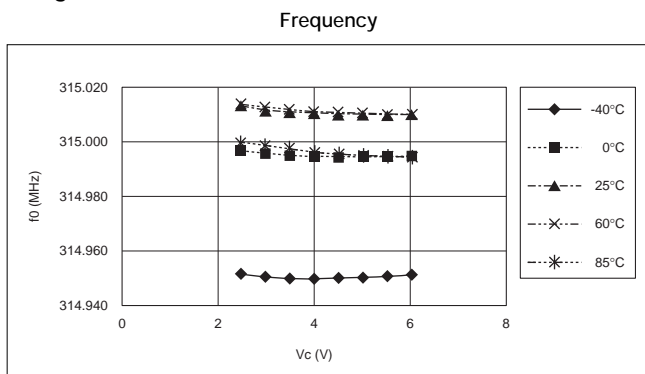

Fig. 5 Land Pattern



1. Fig. 6  $V_{cc}$  Characteristics



Continued on the following page. ↗

## Actual measurements of SAW Oscillator

Continued from the preceding page.

### 2. Fig. 7 CL1 Characteristics

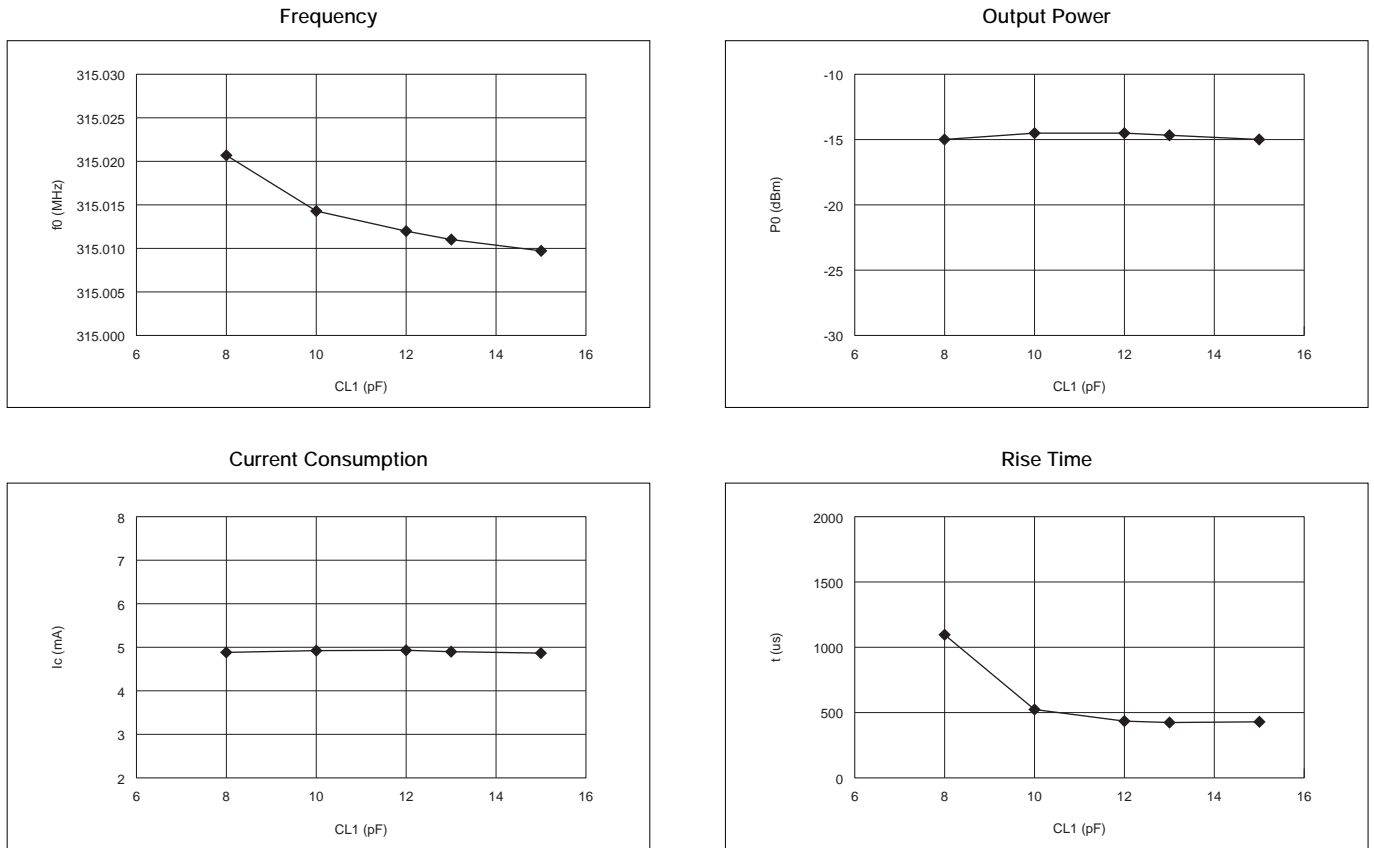

### 3. Fig. 8 CL2 Characteristics

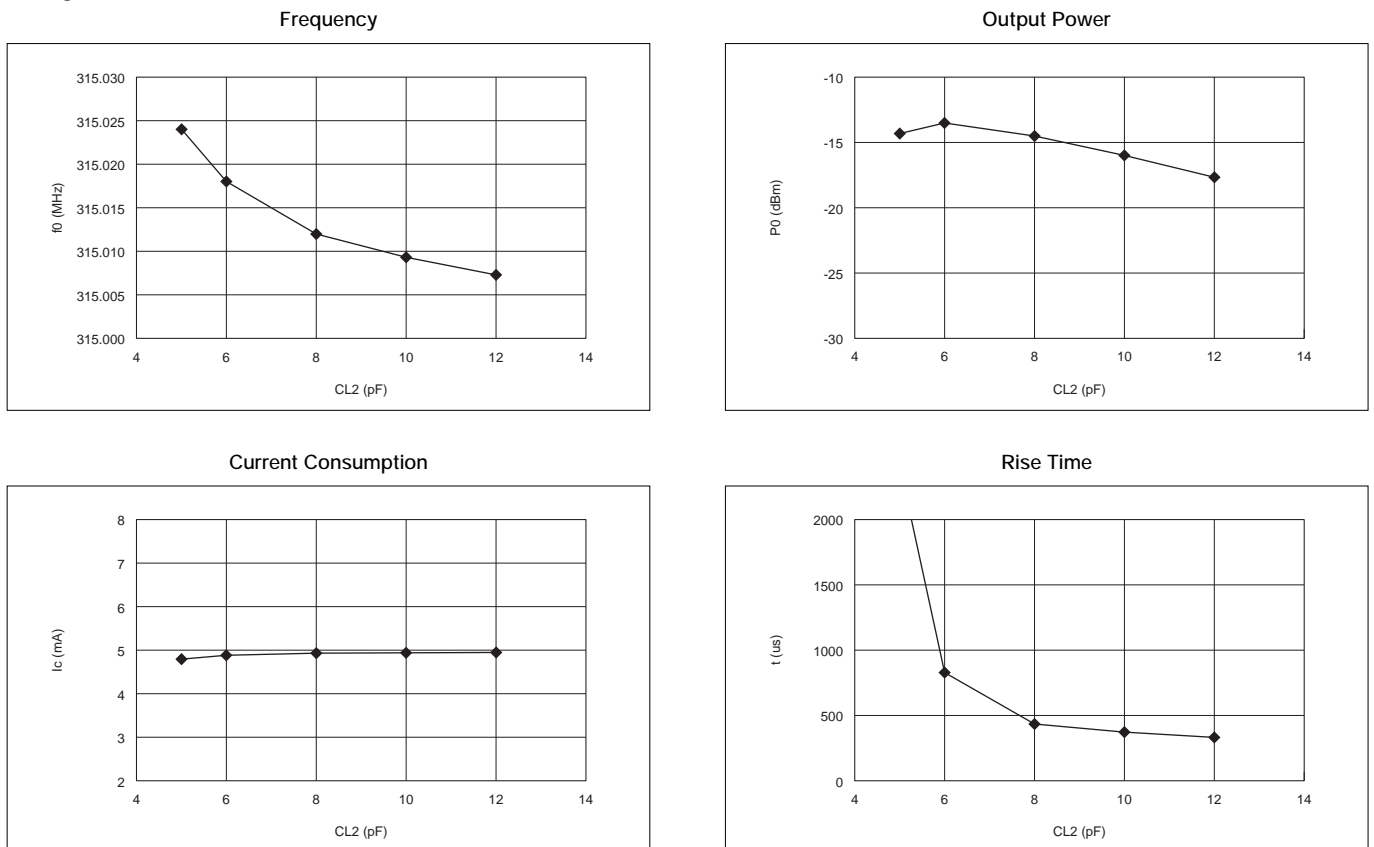

Continued on the following page. ↗

## Actual measurements of SAW Oscillator

Continued from the preceding page.

### 4. Fig. 9 Co Characteristics

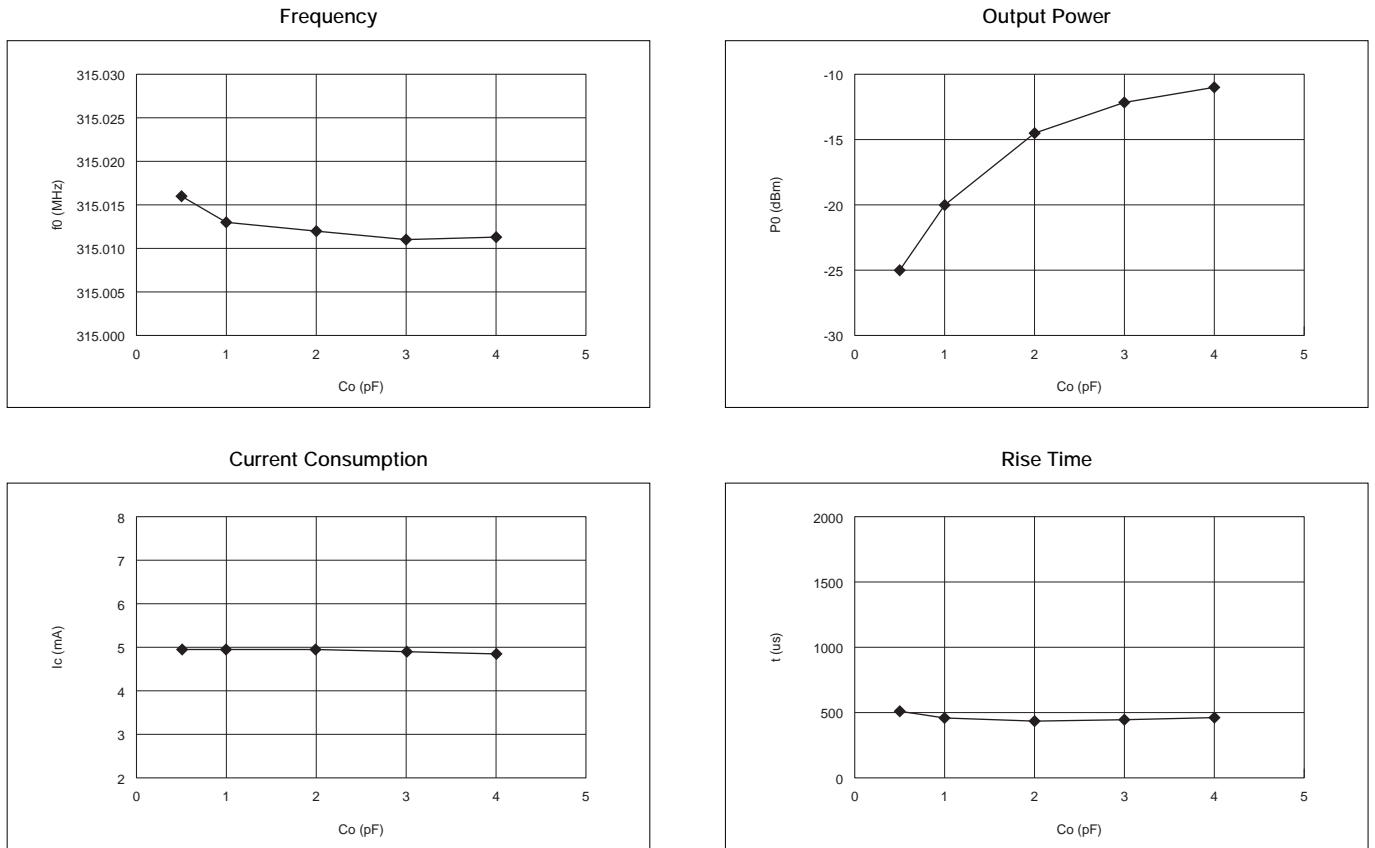

### 5. Fig. 10 Re Characteristics

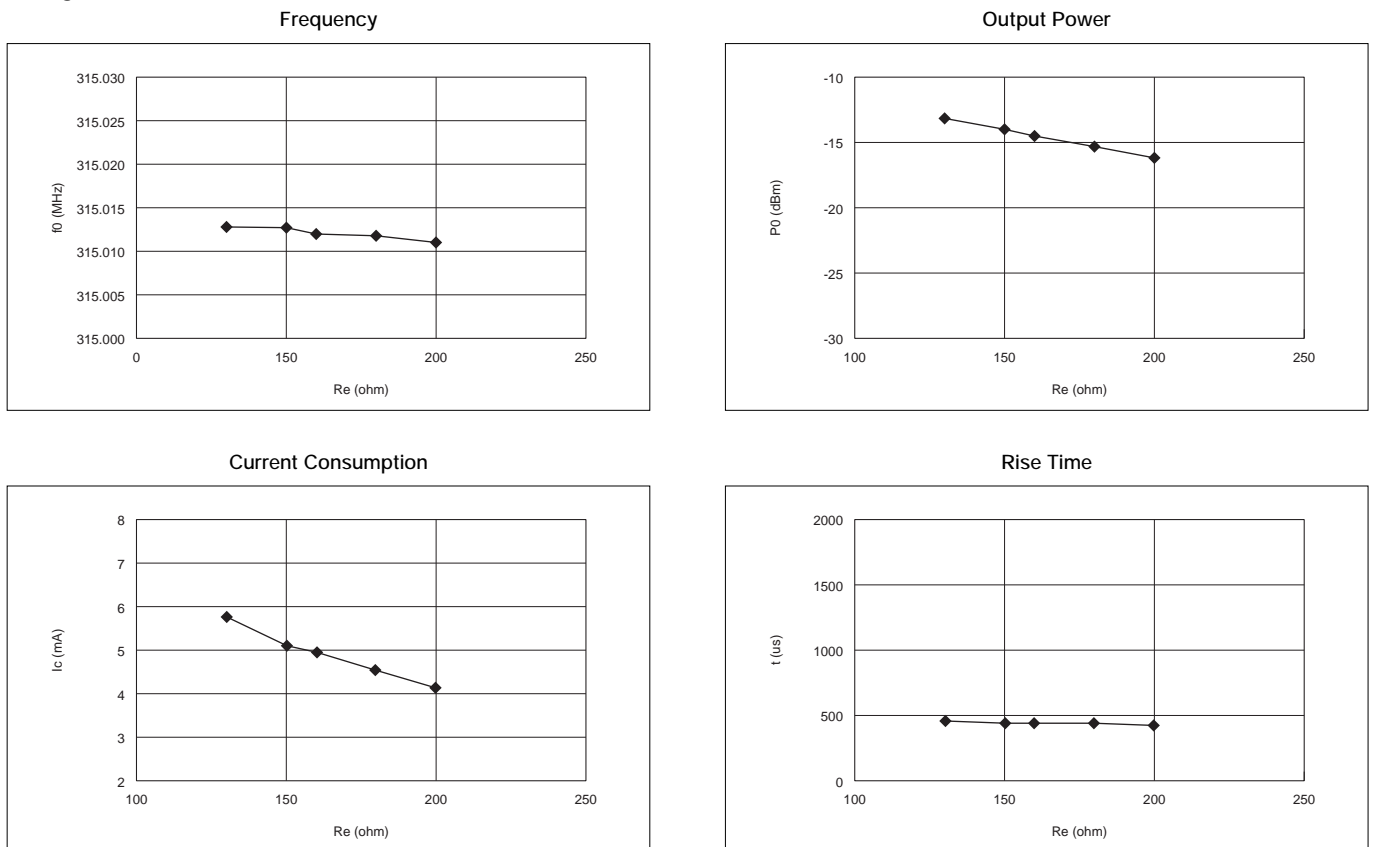

Continued on the following page. ↗

## Actual measurements of SAW Oscillator

Continued from the preceding page.

### ■ 433.92 MHz 1-port SAW Oscillator

Fig. 11 shows an example of oscillator with 1-port SAW RESONATOR. Here, transistor is 2SC4228(NEC), SAW RESONATOR is SARCC433M92BXM0 (433.92 MHz resonator).

Supply voltage ( $V_{cc}$ ) characteristics and temperature characteristics are shown in Fig. 13.

Tr: 2SC4228

SAW: SARCC433M92BXM0

Rb1=Rb2=2k $\Omega$

Re=160 $\Omega$

CL1=10pF GRM1882C1H100JA01B

CL2=8pF GRM1882C1H8RD201B

Co=2pF GRM1884C1H2R0CZ01B

Fig. 11 Oscillator Circuit

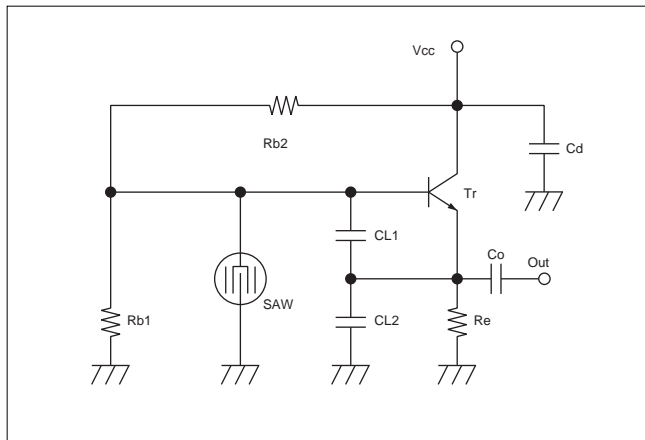
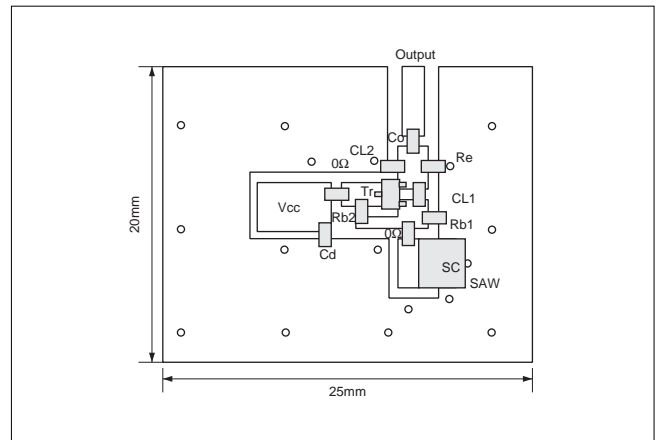
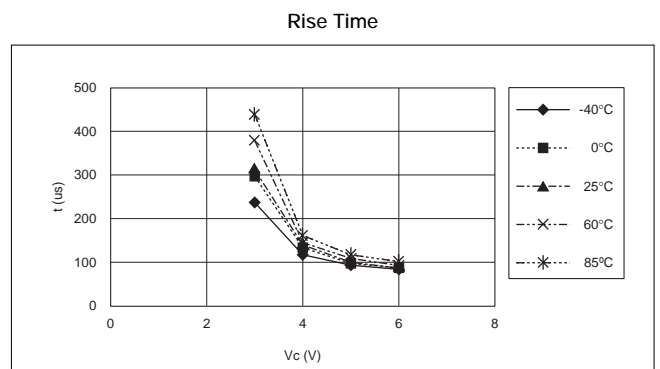
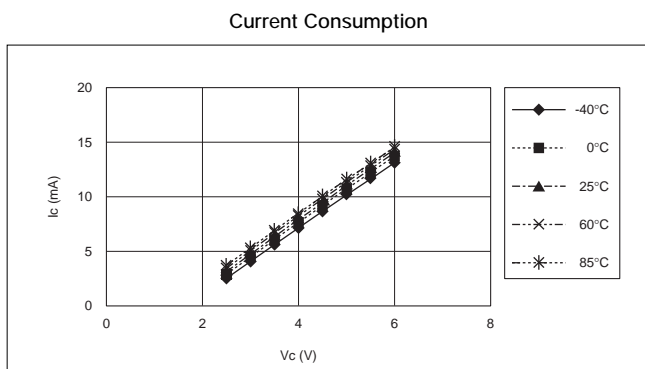
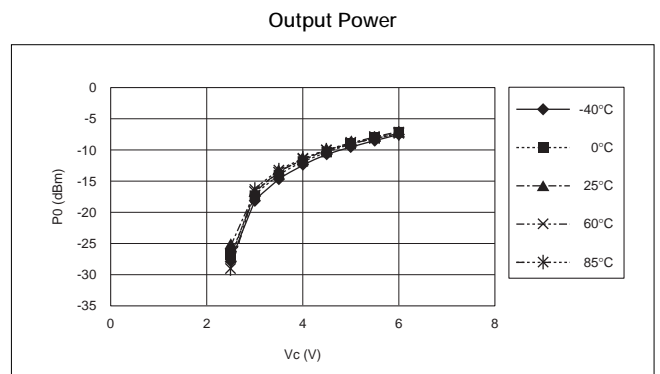
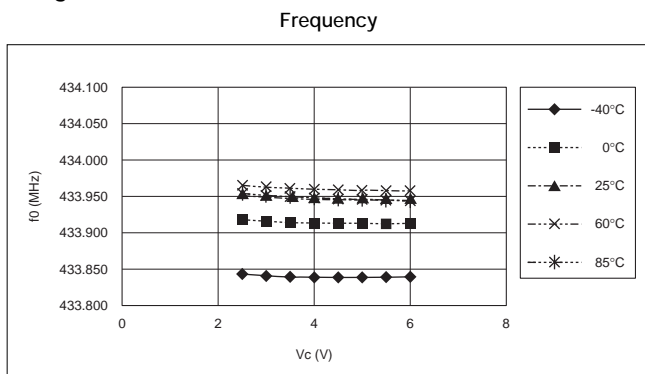

Fig. 12 Land Pattern



1. Fig. 13  $V_{cc}$  Characteristics



Continued on the following page. ↗

## Actual measurements of SAW Oscillator

Continued from the preceding page.

### 2. Fig. 14 CL1 Characteristics

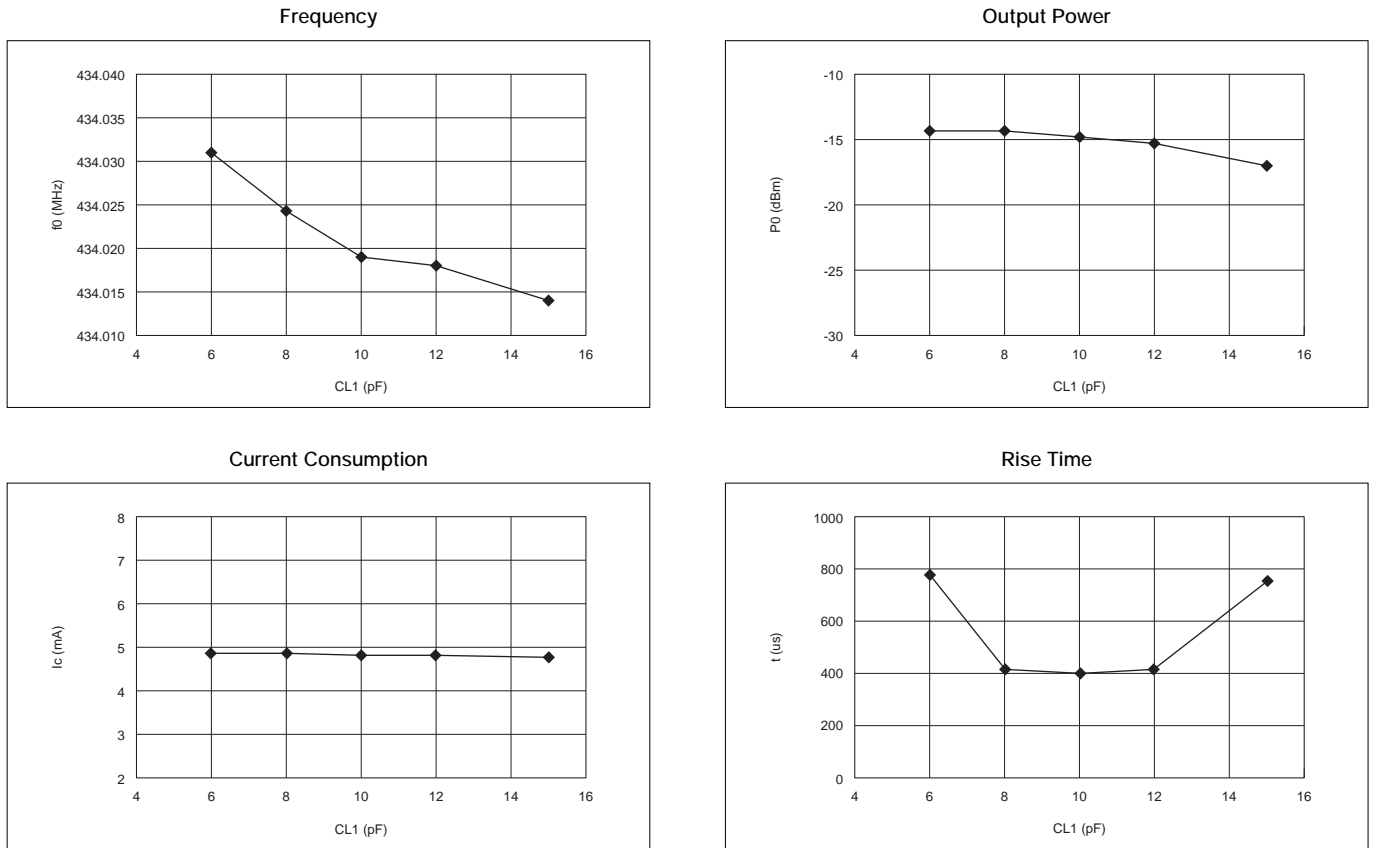

### 3. Fig. 15 CL2 Characteristics

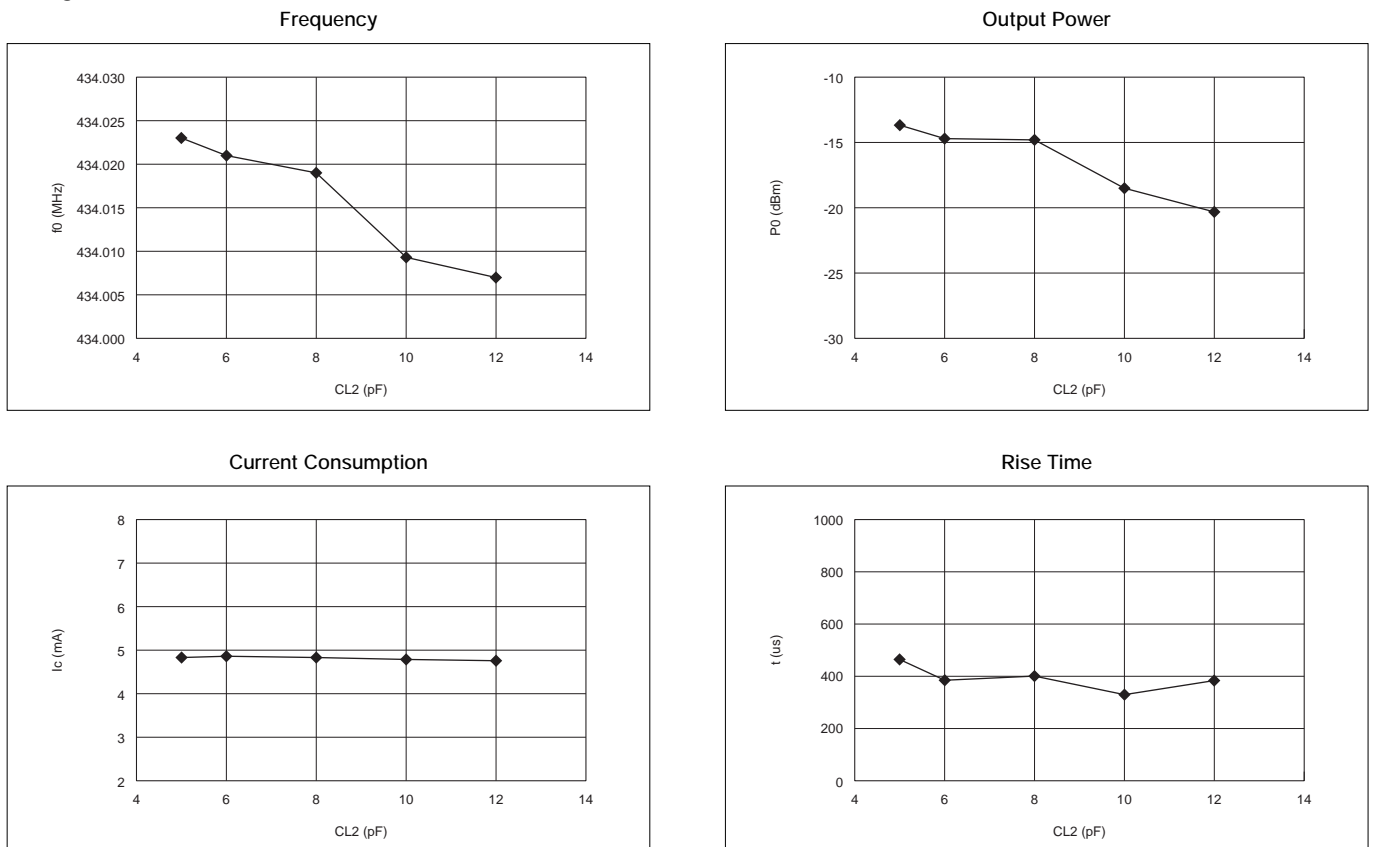

Continued on the following page. ↗

## Actual measurements of SAW Oscillator

Continued from the preceding page.

### 4. Fig. 16 Co Characteristics

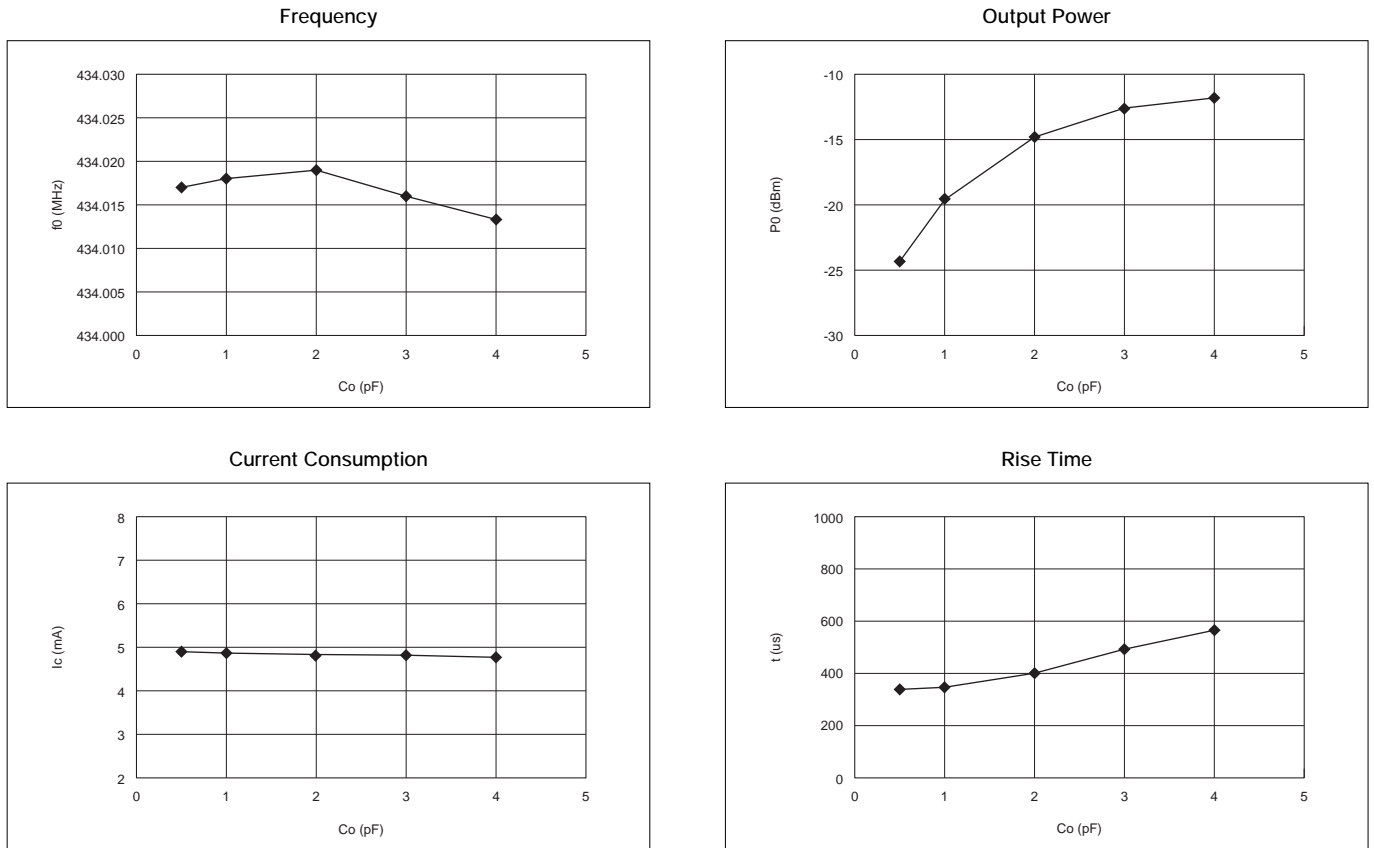

### 5. Fig. 17 Re Characteristics

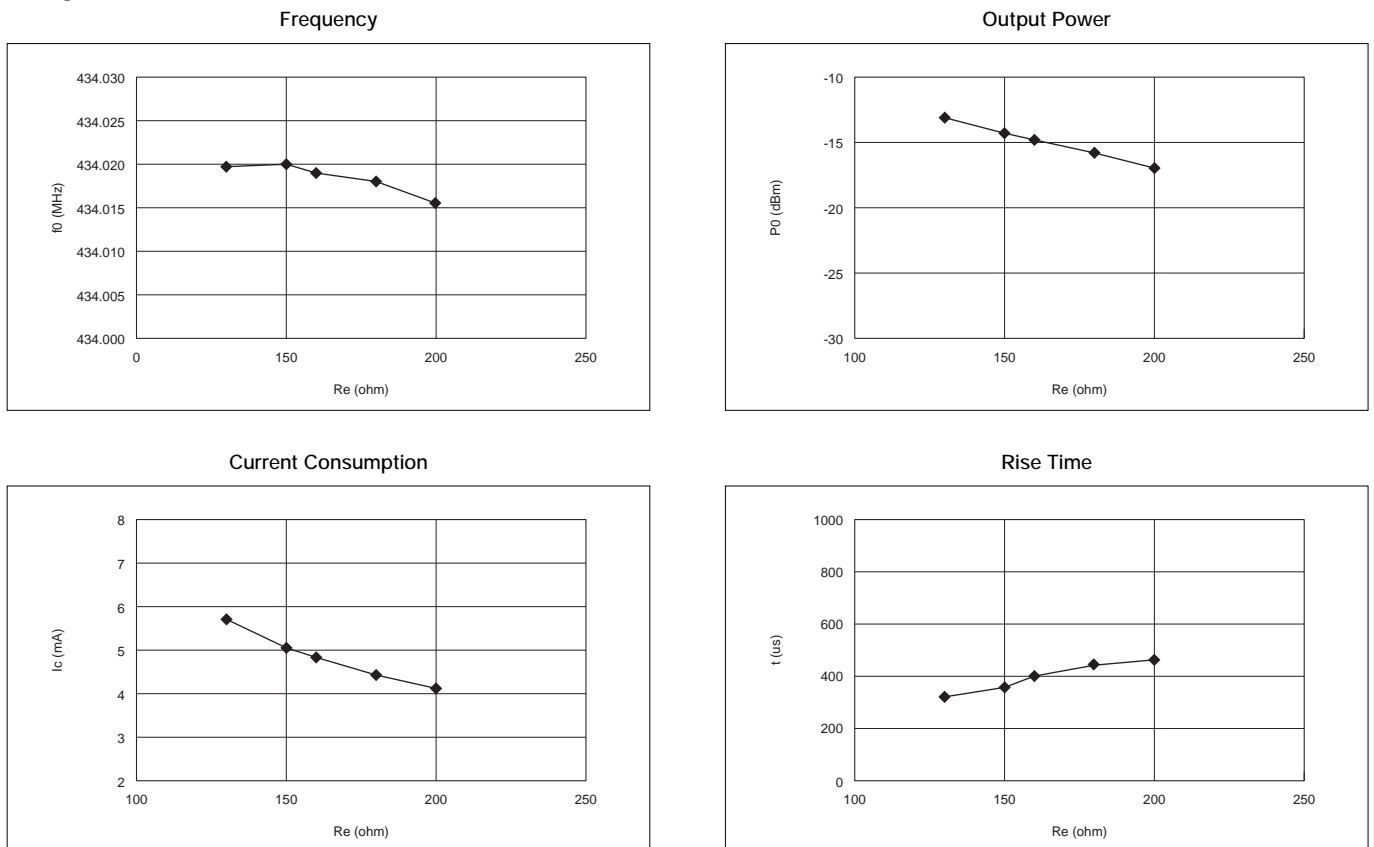

# Keyless Entry System

RF remote control transmitter and receiver for automotive security device is getting popular. MURATA SARCC series are suitable for this application due to the advantage of adjustment-free (or easy adjustment) and high stability. Example of application circuit is shown in Fig.18 and Fig.19.

Fig. 18 Transmitter Circuit

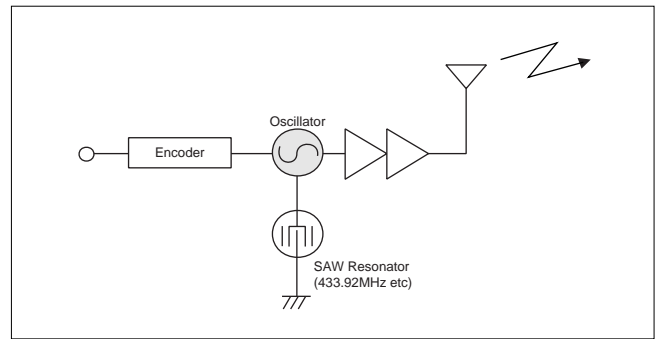
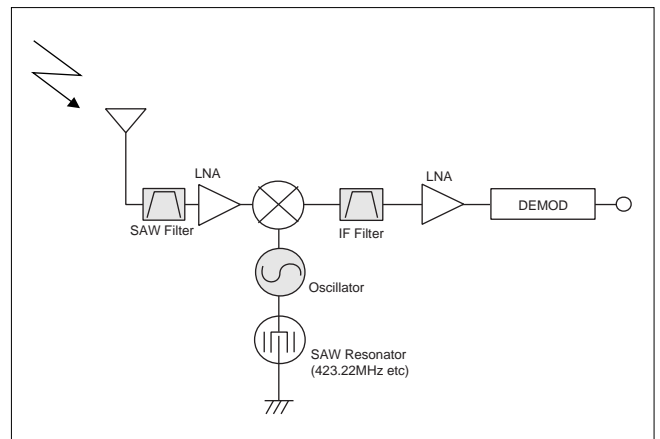
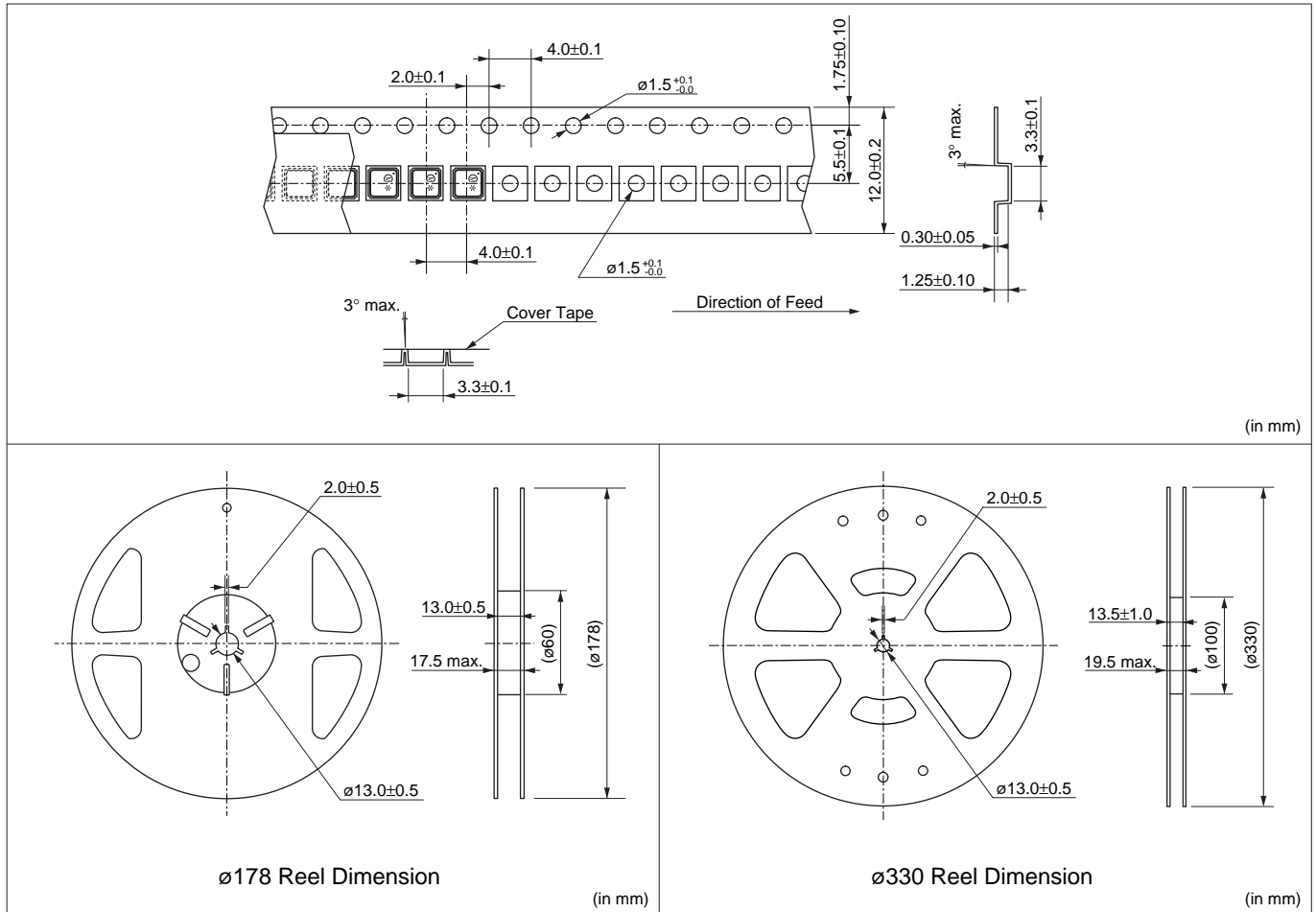

Fig. 19 Receiver Circuit





## Packaging/Notice



### ■ Notice (Handling)

1. Mount this component at the position so that stress by warp or bend of the PCB may not apply to it.
2. It might be a cause of destruction to apply excessive shock on mounting this component on PCB when positioning claw, pick-up nozzle, etc of component placement machine are abraded. Keep regular maintenance which is instructed on each machine to prevent from these kinds of troubles.
3. Mount all terminals, or terminal strength might be degraded.
4. Face this component to PCB.

**⚠Note:**

**1. Export Control**

⟨For customers outside Japan⟩

No muRata products should be used or sold, through any channels, for use in the design, development, production, utilization, maintenance or operation of, or otherwise contribution to (1) any weapons (Weapons of Mass Destruction (nuclear, chemical or biological weapons or missiles) or conventional weapons) or (2) goods or systems specially designed or intended for military end-use or utilization by military end-users.

⟨For customers in Japan⟩

For products which are controlled items subject to the "Foreign Exchange and Foreign Trade Law" of Japan, the export license specified by the law is required for export.

**2. Please contact our sales representatives or product engineers before using the products in this catalog for the applications listed below, which require especially high reliability for the prevention of defects which might directly damage a third party's life, body or property, or when one of our products is intended for use in applications other than those specified in this catalog.**

- |                             |  |
|-----------------------------|--|
| ① Aircraft equipment        | ② Aerospace equipment  |
| ③ Undersea equipment        | ④ Power plant equipment  |
| ⑤ Medical equipment         | ⑥ Transportation equipment (vehicles, trains, ships, etc.)   |
| ⑦ Traffic signal equipment  | ⑧ Disaster prevention / crime prevention equipment   |
| ⑨ Data-processing equipment | ⑩ Application of similar complexity and/or reliability requirements to the applications listed above |

**3. Product specifications in this catalog are as of May 2002. They are subject to change or our products in it may be discontinued without advance notice. Please check with our sales representatives or product engineers before ordering. If there are any questions, please contact our sales representatives or product engineers.**

**4. Please read rating and ⚠CAUTION (for storage, operating, rating, soldering, mounting and handling) in this catalog to prevent smoking and/or burning, etc.**

**5. This catalog has only typical specifications because there is no space for detailed specifications. Therefore, please approve our product specifications or transact the approval sheet for product specifications before ordering.**

**6. Please note that unless otherwise specified, we shall assume no responsibility whatsoever for any conflict or dispute that may occur in connection with the effect of our and/or a third party's intellectual property rights and other related rights in consideration of your use of our products and/or information described or contained in our catalogs. In this connection, no representation shall be made to the effect that any third parties are authorized to use the rights mentioned above under licenses without our consent.**

**7. No ozone depleting substances (ODS) under the Montreal Protocol are used in our manufacturing process.**