

2A Synchronous Buck Li-ion Charger

General Description

The LP28300 is a 2A Li-Ion battery charger intended for 5V wall adapters. It utilizes a 1.5MHz synchronous buck converter topology to reduce power dissipation during charging. Low power dissipation, an internal MOSFET allow a physically small charger that can be embedded in a wide range of handheld applications. The LP28300 includes complete charge termination circuitry, automatic recharge and a $\pm 1\%$ 4.2V float voltage. Input short-circuit protection is included so no blocking diode is required.

Battery charge current, charge timeout and end-of-charge indication parameters are set with external components. Additional features include shorted cell detection, temperature qualified charging and overvoltage protection. The LP28300 is available in a low profile (0.75mm) 10-lead (3mm \times 3mm) DFN package.

Features

- Very Low Power Dissipation
- 2A Maximum Charge Current
- No External MOSFETs and Blocking Diode Required
- Constant-Current/Constant-Voltage Operation with Thermal Regulation to Maximize Charge Rate Without Risk of Overheating
- Charges Single Cell Li-Ion Batteries Directly from USB Port
- Drainage Charge Current Thermal Regulation Status Outputs for LED or System Interface
- Optional Battery Temperature Monitoring Before and During Charge Automatic Sleep Mode for Low-Power
- Consumption Available in 3mm \times 3mm TDFN-10 Package
- RoHS Compliant and 100% Lead (Pb)-Free

Order Information

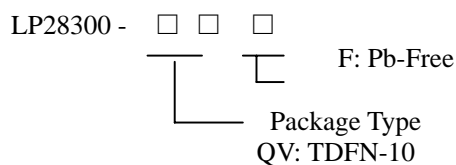

Applications

- ✧ Portable Media Players
- ✧ Cellular and Smart mobile phone
- ✧ PDA/DSC
- ✧ Handheld Battery-Powered Devices
- ✧ Handheld Computers
- ✧ Charging Docks and Cradles

Typical Application Circuit

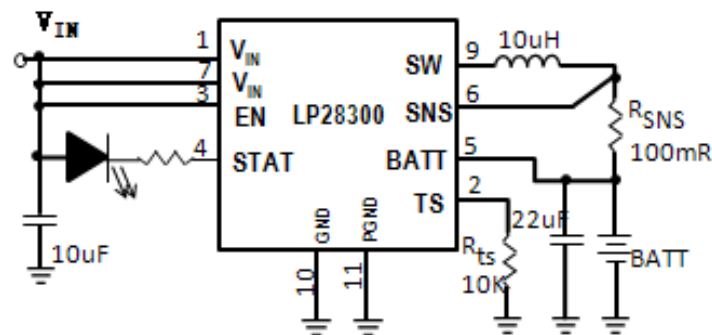

Marking Information

Please see website.

Functional Pin Description

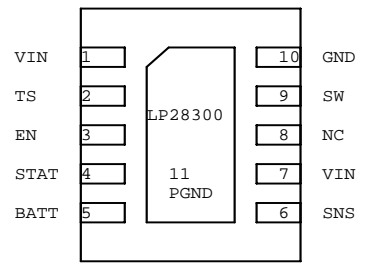
Package Type	Pin Configurations
TDFN- 10	

Pin Description

PIN	PIN Number	DESCRIPTION
VIN	1,7	Positive Supply Voltage Input. This pin connects to the power devices inside the chip. V_{IN} ranges from 4V to 5.5V for normal operation. Operation down to the under-voltage lockout threshold is allowed with current limited wall adapters. Decouple with a 10 μ F or larger surface mounted ceramic capacitor.
TS	2	NTC (Negative Temperature Coefficient) Thermistor Input. With an external 10k Ω NTC thermistor to ground, this pin senses the temperature of the battery pack and stops the charger when the temperature is out of range. To disable the temperature qualification function, ground the NTC pin.
EN	3	Enable Input Pin. Pulling the EN pin high places the LP28300 into a low power state where the BAT drain current drops to less than 3 μ A and the supply current is reduced to less than 50 μ A. For normal operation, pull the pin low.
STAT	4	Open-Drain Charge Status Output. When the battery is charging, the STAT pin is pulled low by an internal N-channel MOSFET. When the charge cycle is completed, When the LP28300 detects an under voltage lockout condition, STAT is forced high impedance.
BATT	5	Battery Charger Output Terminal. Connect a 22 μ F ceramic chip capacitor between BAT and PGND to keep the ripple voltage small.
SNS	6	Internal Sense Resistor. Connect to external inductor. Current Amplifier Sense Input. A sense resistor, R_{SENSE} , must be connected between the SENSE and BAT pins. The maximum charge current is equal to $100mV/R_{SENSE}$.
NC	8	No connector.
SW	9	Switch Node Connection. This pin connects to the drains of the internal main and synchronous power MOSFET switches. Connect to external inductor.
GND	10	Ground.
PGND	11	Power Ground Pad.

Typical Application Circuits

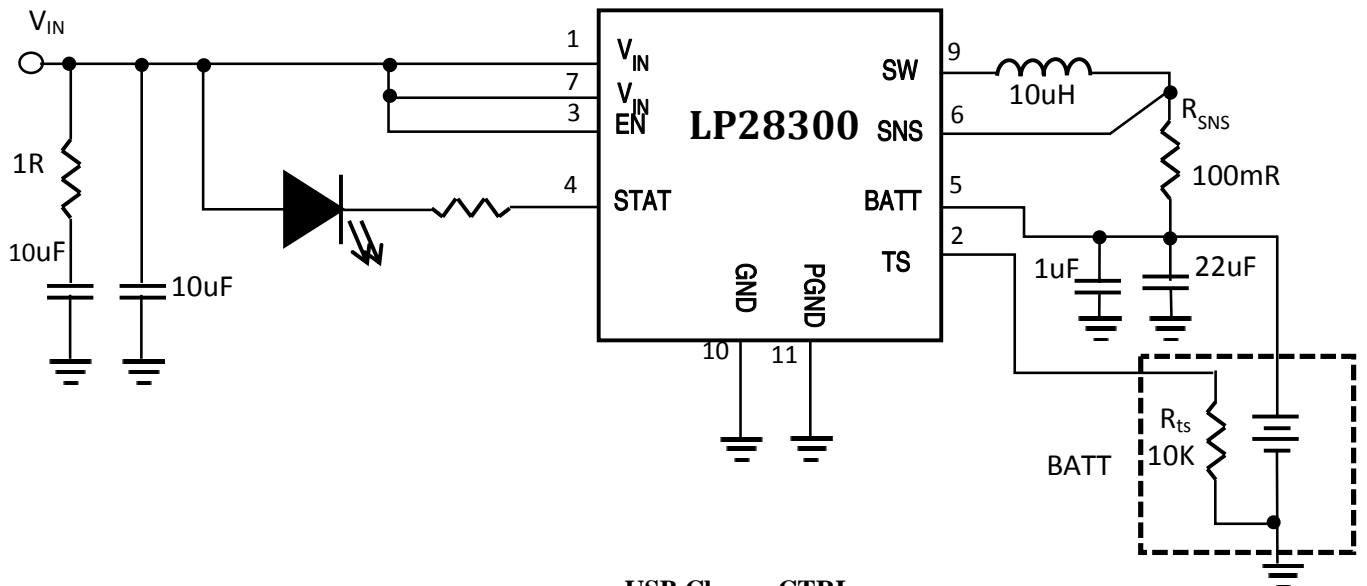
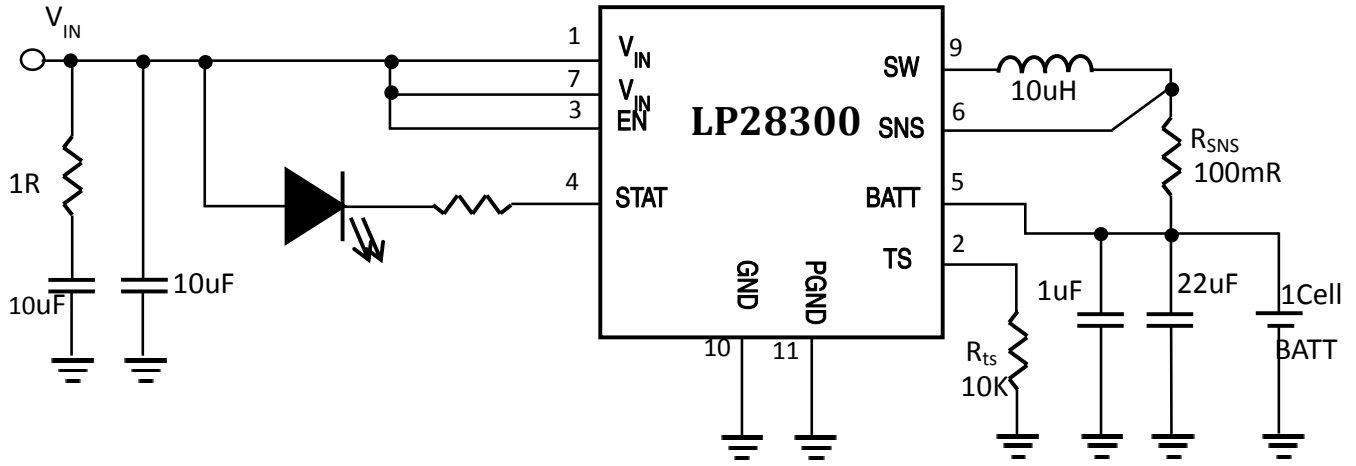

USB Charge CTRL

H:USB Charging, $I_{set}=500mA$
 L:DC Adapter Charging, $I_{set}=1300mA$

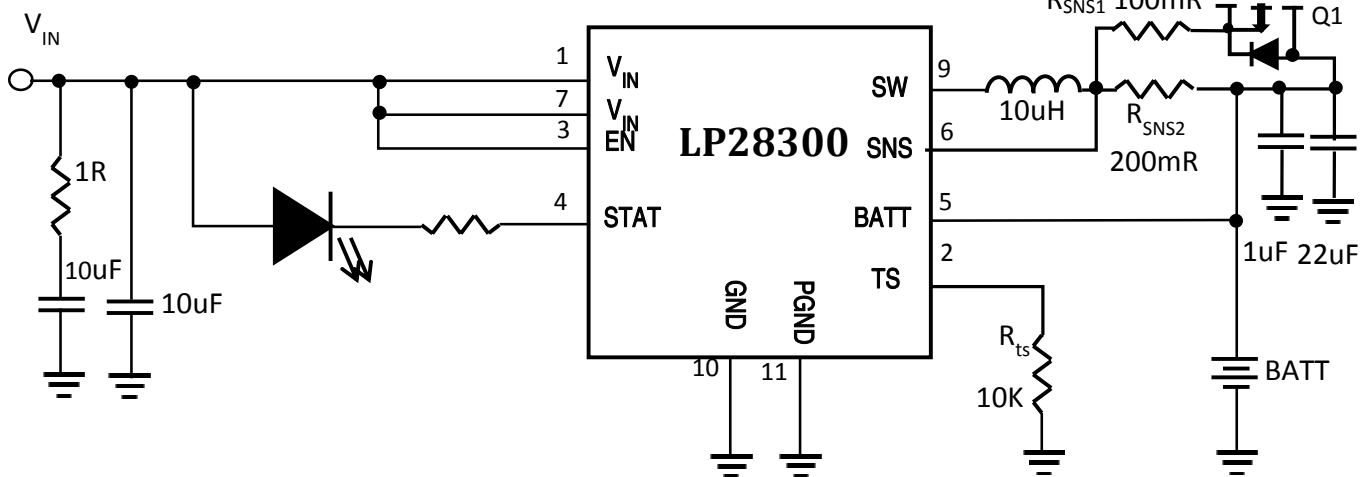

Function Block Diagram

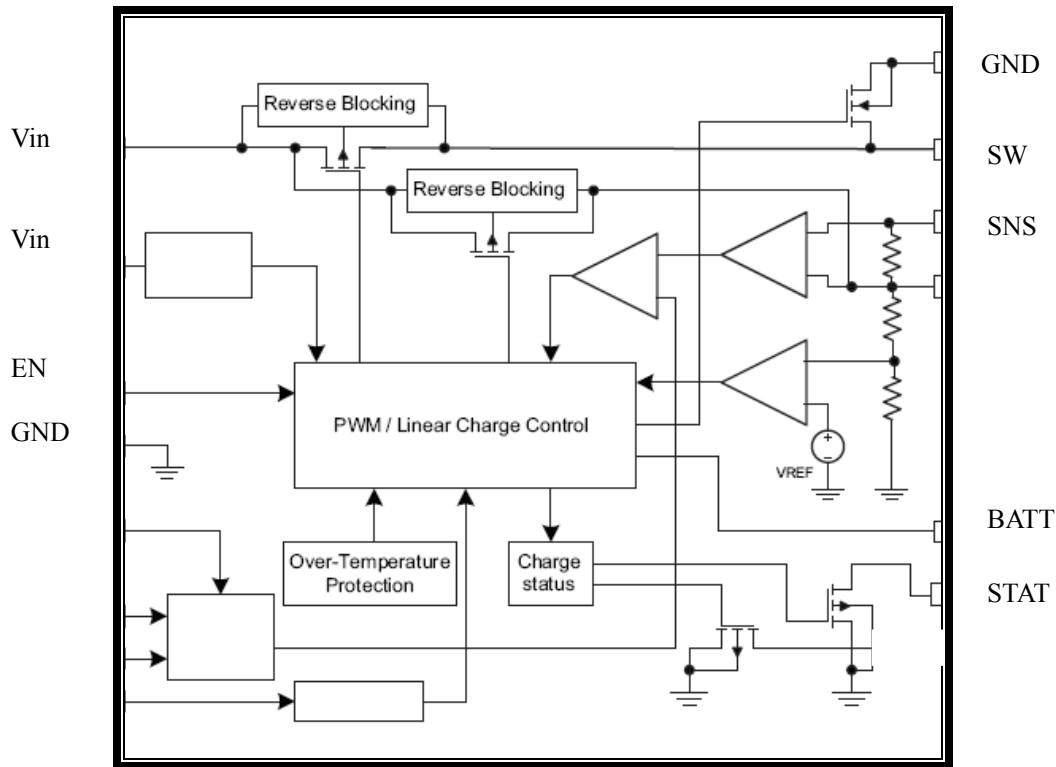

Absolute Maximum Ratings

- ✧ Input Voltage to GND (VIN) ----- 2.6V to 6.5V
- ✧ BAT, I_{SET}, STAT (VX) ----- 0.3V to VIN+0.3V
- ✧ BAT Short-Circuit Duration ----- Continuous
- ✧ BAT Pin Current ----- 2500mA
- ✧ Maximum Junction Temperature ----- 125°C
- ✧ Operating Junction Temperature Range (TJ) ----- -40°C to 85°C
- ✧ Maximum Soldering Temperature (at leads, 10 sec) ----- 260°C

Thermal Information

- ✧ Maximum Power Dissipation (PD, TA<40°C) ----- 2W
- ✧ Thermal Resistance (JA) ----- 46°C/W

Electrical Characteristics (The specifications which apply over the full operating temperature range, otherwise specifications are at TA = 25°C. VCC = 5V, unless otherwise noted.)

SYMBOL	PARAMETER	CONDITIONS	MIN	TYP.	MAX	UNITS
V _{IN}	Adapter/USB Voltage Range		2.65	5	6	V
I _{CC}	Input Supply Current	Charge Mode (Note 4), R _{ISET} = 10k Standby Mode (Charge Terminated)		300	2000	uA
		Shutdown Mode (R _{ISET} Not Connected, V _{CC} < V _{BAT} , or V _{CC} < V _{VUV})		200	500	
				25	50	
V _{FLOAT}	Regulated Output (Float) Voltage	0°C ≤ TA ≤ 85°C, I _{BAT} = 40mA	4.158	4.2	4.242	V
I _{BAT}	BAT Pin Current	R _{SNS} = 100mΩ, Current Mode	860	1000	1120	mA
		R _{SNS} = 68mΩ, Current Mode	1300	1470	1620	
		Standby Mode, V _{BAT} = 4.2V Shutdown Mode (R _{ISET} Not Connected) Sleep Mode, V _{CC} = 0V	0	-2.5 ±1	-6 ±2	uA
		±1	±2			
I _{TRIKL}	Trickle Charge Current	V _{BAT} < V _{TRIKL} , R _{SNS} = 100mΩ (Note 5)	80	100	120	mA
V _{TRIKL}	Trickle Charge Threshold Voltage	R _{SNS} = 100mΩ, V _{BAT} Rising (Note 5)	2.8	2.9	3.0	V
V _{TRHYS}	Trickle Charge Hysteresis Voltage	R _{SNS} = 100mΩ, (Note 5)	60	80	110	mV
V _{SNS}	SNS Pin Voltage	R _{ISET} = 10k, Current Mode	88	100	116	mV
I _{STAT}	STAT Pin Weak Pull-Down Current	V _{STAT} = 5V	8	20	35	uA
V _{STAT}	STAT Pin Output Low Voltage	I _{STAT} = 5mA		0.35	0.6	V
ΔV _{RESTAT}	Recharge Battery Threshold Voltage	V _{FLOAT} - V _{RESTAT}	100	150	200	mV
T _{LIM}	Junction Temperature in Constant Temperature Mode				120	°C
T _{SS}	Soft-Start Time	I _{BAT} = 0 to I _{BAT} = 850V/R _{ISET}		100		uS
I _{SNS}	I _{SET} Pin Pull-Up Current			3		uA

Typical Operating Characteristics

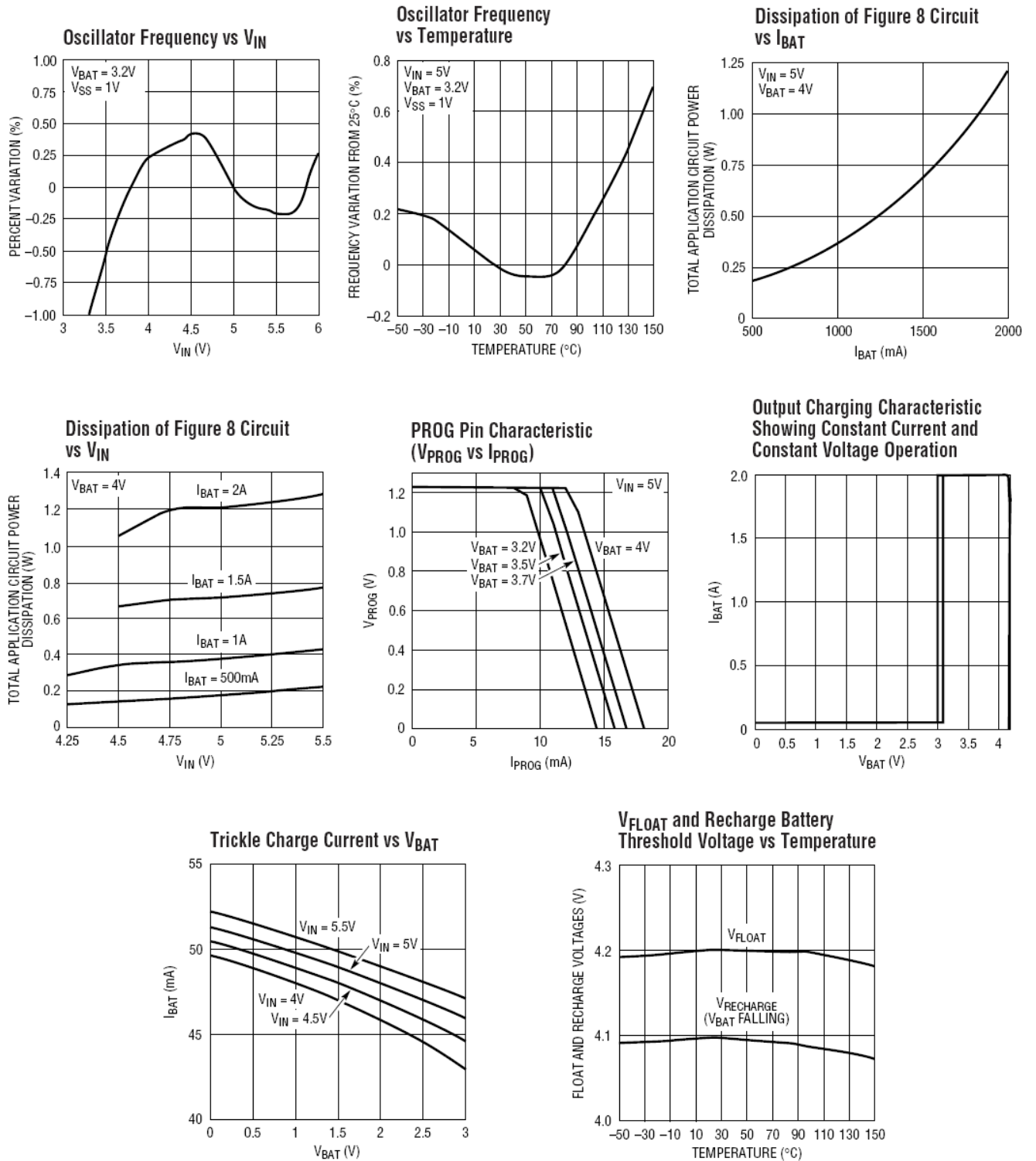

Operation

The LP28300 is a constant current, constant voltage Li-Ion battery charger controller that uses a current mode PWM step-down (buck) switching architecture. The charge current is set by an external sense resistor (R_{SENSE}) across the SENSE and BAT pins. The final battery float voltage is internally set to 4.2V per cell. For batteries like lithium-ion that require accurate final float voltage, the internal 2.4V reference, voltage amplifier and the resistor divider provide regulation with $\pm 1\%$ accuracy.

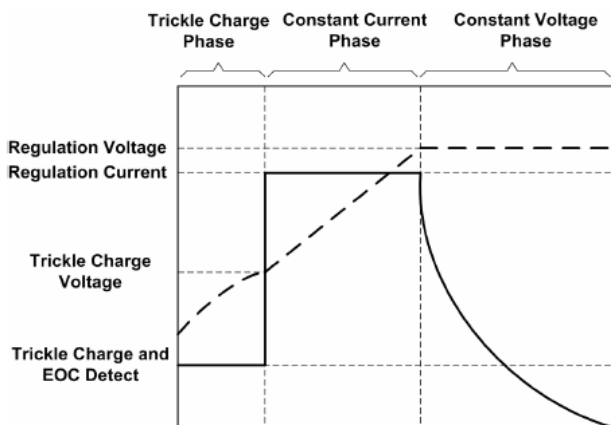

Figure 1. Typical Charge Profile

A charge cycle begins when the voltage at the VCC pin rises above the UVLO level and is 250mV or more greater than the battery voltage. At the beginning of the charge cycle, if the battery voltage is less than the trickle charge threshold, 2.9V for the 4.2 version, the charger goes into trickle charge mode. The trickle charge current is internally set to 15% of the full-scale current. If the battery voltage stays low for 30 minutes, the battery is considered faulty and the charge cycle is terminated. When the battery voltage exceeds the trickle charge threshold, the charger goes into the full-scale constant current charge mode. In constant current mode, the charge current is set by the external sense resistor R_{SENSE} and an internal 100mV reference;

$$I_{CHG} = \frac{V_{SNS(CHG)}}{R_{SENSE}} = \frac{100mV}{R_{SENSE}}$$

When the battery voltage approaches the programmed float voltage, the charge current will

start to decrease. When the current drops to 25% of the full-scale charge current, an internal comparator turns off the internal pull-down N-channel MOSFET at the STAT pin, and connects a weak current source to ground to indicate a near end-of-charge condition. A 10k Ω NTC (negative temperature coefficient) thermistor can be connected from the NTC pin to ground for battery temperature qualification. The charge cycle is suspended when the temperature is outside of the 0°C to 50°C window.

Shutdown

The LP28300 can be shut down by pulling the COMP pin to ground which pulls the GATE pin high turning off the external P-channel MOSFET. When the COMP pin is released, the internal timer is reset and a new charge cycle starts. In shutdown, the output of the CHRГ pin is high impedance and the quiescent current remains at 1.5mA. Removing the input power supply will put the charger into sleep mode. If the voltage at the VCC pin drops below ($V_{BAT} + 250mV$) or below the UVLO level, the LP28300 goes into a low current ($I_{CC} = 10\mu A$) sleep mode, reducing the battery drain current.

Automatic Recharge

Once the charge cycle is terminated, the LP28300 continuously monitors the voltage on the BAT pin using a comparator with a 2ms filter time ($t_{RECHARGE}$). A charge cycle restarts when the battery voltage falls below 4.05V (which corresponds to approximately 80% to 90% battery capacity). This ensures that the battery is kept at or near a fully charged condition and eliminates the need for periodic charge cycle initiations. STAT output enters a strong pull-down state during recharge cycles.

Battery Temperature Detection

A negative temperature coefficient (NTC) thermistor located close to the battery pack can be used to monitor battery temperature and will not allow charging unless the battery temperature is within an acceptable range. Connect a 10k Ω thermistor from the TS pin to ground. If the

temperature rises to 50°C, the resistance of the

NTC will be approximately 4.2kΩ. With the 85μA pull-up current source, the Hot temperature voltage threshold is 360mV. For Cold temperature, the voltage threshold is set at 2.4V which is equal to 0°C ($R_{ts} \cong 28k\Omega$) with 85μA of pull-up current. If the temperature is outside the window, the GATE pin will be pulled up to VCC and the timer frozen while the output status at the STAT pin remains the same. The charge cycle begins or resumes once the temperature is within the acceptable range. Short the TS pin to ground to disable the temperature qualification feature. However the user may modify these thresholds by adding two external resistor. See figure 3.

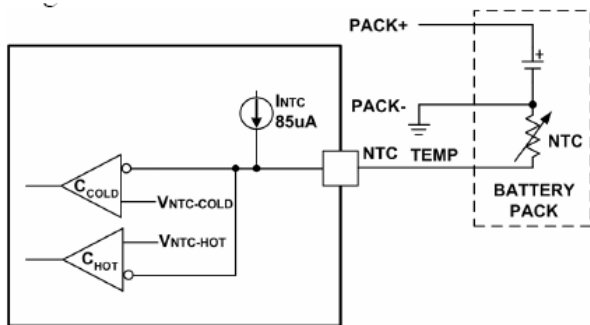

Figure 2. Temperature Sensing Configuration

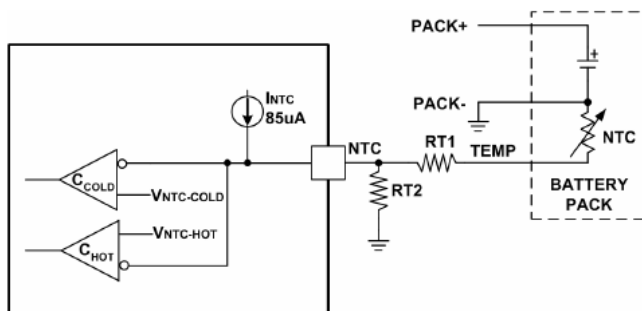

Figure 3. Temperature Sensing Thresholds

Input and Output Capacitors

Since the input capacitor is assumed to absorb all input switching ripple current in the converter, it must have an adequate ripple current rating. Worst-case RMS ripple current is approximately

one-half of output charge current. Actual

capacitance value is not critical. Solid tantalum capacitors have a high ripple current rating in a relatively small surface mount package, but caution must be used when tantalum capacitors are used for input bypass. High input surge currents can be created when the adapter is hot-plugged to the charger and solid tantalum capacitors have a known failure mechanism when subjected to very high turn-on surge currents. Selecting the highest possible voltage rating on the capacitor will minimize problems. Consult with the manufacturer before use. The selection of output capacitor C_{OUT} is primarily determined by the ESR required to minimize ripple voltage and load step transients. The output ripple ΔV_{OUT} is approximately bounded by:

$$\Delta V_{OUT} \leq \Delta I_L \left(ESR + \frac{1}{8f_{OSC} C_{OUT}} \right)$$

Since ΔI_L increases with input voltage, the output ripple is highest at maximum input voltage. Typically, once the ESR requirement is satisfied, the capacitance is adequate for filtering and has the necessary RMS current rating. Switching ripple current splits between the battery and the output capacitor depending on the ESR of the output capacitor and the battery impedance. EMI considerations usually make it desirable to minimize ripple current in the battery leads. Ferrite beads or an inductor may be added to increase battery impedance at the 500kHz switching frequency. If the ESR of the output capacitor is 0.2Ω and the battery impedance is raised to 4Ω with a bead or inductor, only 5% of the current ripple will flow in the battery.

Inductor Selection

A high (1.5MHz) operating frequency was chosen for the buck switcher in order to minimize the size of the inductor. However, take care to use inductors with low core losses at this frequency. A good

choice is the IHLP-2525AH-01 from Vishay Dale.

To calculate the inductor ripple current:

$$\Delta I_L = \frac{V_{BAT} - \frac{V_{BAT}^2}{V_{IN}}}{L \cdot f}$$

where V_{BAT} is the battery voltage, V_{IN} is the input voltage, L is the inductance and f is the PWM oscillator frequency (typically 1.5MHz). Maximum inductor ripple current occurs at maximum V_{IN} and $V_{BAT} = V_{IN}/2$.

Peak inductor current will be:

$$I_{PK} = I_{BAT} + 0.5 \cdot \Delta I_L$$

where I_{BAT} is the maximum battery charging current.

When sizing the inductor make sure that the peak current will not exceed the saturation current of the inductors. Also, ΔI_L should never exceed $0.4(I_{BAT})$ as this may interfere with proper operation of the

output short-circuit protection comparator. 1.5μH provides reasonable inductor ripple current in a

typical application. With 1.5μH and 2A charge current:

$$\Delta I_L = \frac{2.85V - \frac{2.85V^2}{5.5V}}{1.5\mu H \cdot 1.5MHz} = 0.61A_{P-P}$$

and

$$I_{PK} = 2.31A$$

Layout Considerations

Switch rise and fall times are kept under 5ns for maximum efficiency. To minimize radiation, the SW pin and input bypass capacitor leads (between V_{IN} and PGND) should be kept as short as possible. A ground plane should be used under the switching circuitry to prevent inter plane coupling. The exposed pad must be connected to the ground plane for proper power dissipation. The other paths contain only DC and/or 1.5MHz tri-wave ripple current and are less critical. With the exception of the input and output filter capacitors (which should be connected to PGND) all other components that return to ground should be connected to GND.

Packaging Information

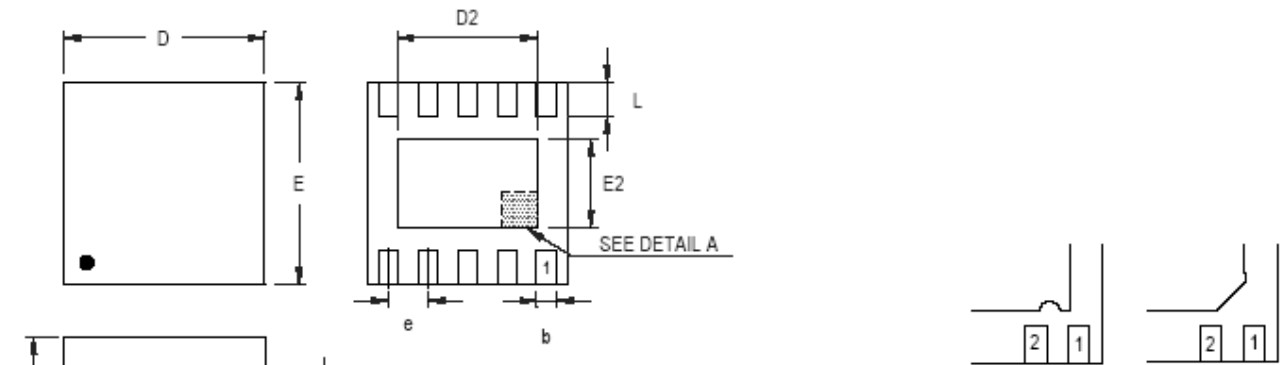

DETAIL A

Pin #1 ID and Tie Bar Mark Options

Note : The configuration of the Pin #1 identifier is optional, but must be located within the zone indicated.

Symbol	Dimensions In Millimeters		Dimensions In Inches	
	Min	Max	Min	Max
A	0.700	0.800	0.028	0.031
A1	0.000	0.050	0.000	0.002
A3	0.175	0.250	0.007	0.010
b	0.180	0.300	0.007	0.012
D	2.950	3.050	0.116	0.120
D2	2.300	2.650	0.091	0.104
E	2.950	3.050	0.116	0.120
E2	1.500	1.750	0.059	0.069
e	0.500		0.020	
L	0.350	0.450	0.014	0.018

W-Type 10L DFN 3x3 Package