

# STANDARD LOW POWER INDUCTORS

## Switch Mode Power Converters & Ripple Filters

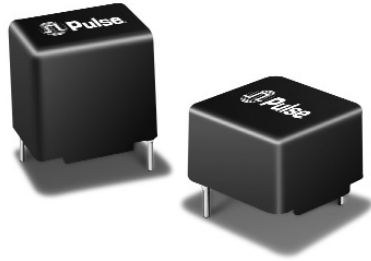

- Designed for general purpose use
- High inductance stability with varying volt-seconds and load currents
- Compact, standard packages
- Low profile or vertical packages

### Electrical Specifications @ 25°C — Operating Temperature -40°C to 130°C

Low Profile Part Number	Vertical Part Number	REFERENCE OPERATING VALUES				DESIGN CONTROL VALUES		
		Inductance Typical (μH)	I <sub>dc</sub> (AMPS) <sup>1</sup>	Maximum E <sub>TOP</sub> <sup>2</sup> (V-μSec)	Energy Storage (μJ) <sup>1</sup>	Inductance No DC (μH ± 20%)	20 KHz Test mV No DC	DCR (Ω MAX)
PE-52625	PE-52645	150	1.7	80	215	145	110	.42
PE-52626	PE-52646	220	1.5	90	240	226	140	.42
PE-52627	PE-52647	330	1.0	100	165	316	170	.78
PE-52628	PE-52648	470	.90	120	190	480	210	1.26
PE-52629	PE-52649	680	.85	175	245	690	250	1.50
PE-52630	PE-52650	820	.75	175	230	780	270	2.40
PE-52631	PE-52651	1000	.50	175	125	975	300	2.60

NOTES: 1. I<sub>dc</sub> rated for 40°C Temperature rise @ low E<sub>TOP</sub>. 2. Derate current 20% at this E<sub>TOP</sub>.

### Mechanicals

#### Low Profile Package

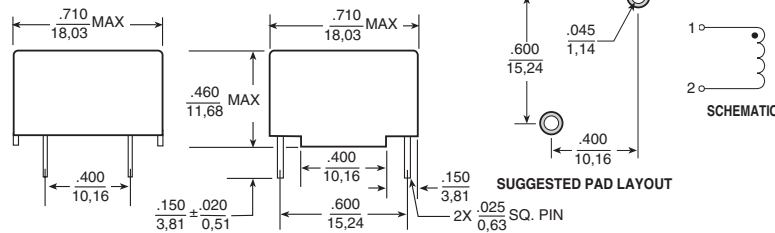

#### Vertical Package

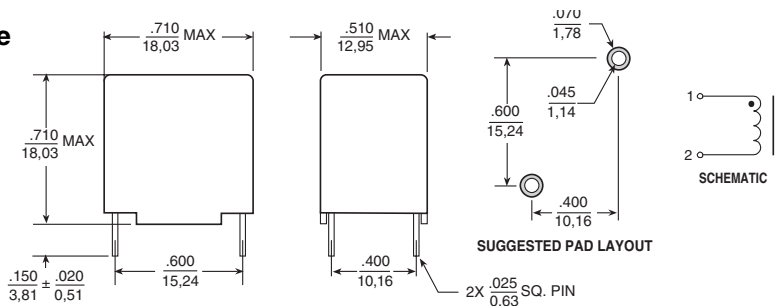

Unless otherwise specified, all tolerances are ± .010 / 0,25

Dimensions: inches / mm

#### Inductance Characteristics

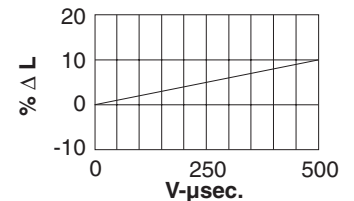

#### Inductance Variance vs. E.T.

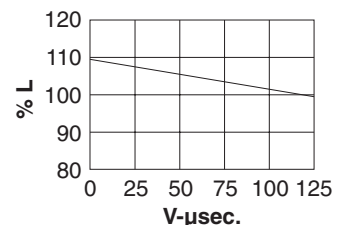

#### Inductance Variance vs. Load Current

### For More Information :

#### UNITED STATES (Worldwide)

12220 World Trade Drive  
San Diego, CA 92128  
U.S.A.  
http://www.pulseeng.com  
TEL: 858 674 8100  
FAX: 858 674 8262

#### UNITED KINGDOM (Northern Europe)

1 & 2 Huxley Road  
The Surrey Research Park  
Guildford, Surrey GU2 5RE  
United Kingdom  
TEL: 44 1483 401700  
FAX: 44 1483 401701

#### FRANCE (Southern Europe)

Zone Industrielle  
F-39270  
Orgelet  
France  
TEL: 33 3 84 35 04 04  
FAX: 33 3 84 25 46 41

#### SINGAPORE (Southern Asia)

150 Kampong Ampat  
#07-01/02  
KA Centre  
Singapore 368324  
TEL: 65 6287 8998  
FAX: 65 6280 0080

#### TAIWAN, R.O.C. (Northern Asia)

3F-4, No. 81, Sec. 1  
HsinTai Wu Road  
Hsi-Chih, Taipei Hsien  
Taiwan, R.O.C.  
Tel: 886 2 2698 0228  
FAX: 886 2 2698 0948

#### HONG KONG (China/Hong Kong)

9/F, Phase 2, Tai Sang  
Shatin Warehouse Centre  
6 Wong Chuk Yeung Street  
Fotan, Shatin, Hong Kong  
TEL: 852 2788 6588  
FAX: 852 2776 1055

#### DISTRIBUTOR

Performance warranty of products offered on this data sheet is limited to the parameters specified. Data is subject to change without notice. Other brand and product names mentioned herein may be trademarks or registered trademarks of their respective owners.