

IGBT 600V/10A High Speed

# STK621-015

## 1. Overview:

This IC is a 3-phase Inverter power hybrid IC containing power elements (IGBT and FRD), pre-driver, over-current protection circuit.

## 2. Application:

3-phase Inverter Motor. Induction Motor. Brushless-DC Motor

## 3. Features:

- Integrates power elements (IGBT and FRD), pre-driver, and protective circuit.
- Protective circuits including over-current (bus line), and pre-drive low voltage protection are built in.
- Direct input of CMOS level control signals without an insulating circuit (photo-coupler, etc) is possible.
- A single power supply drive is enabled through the use of bootstrap circuits for upper power supplies. (externally set)
- Built-in simultaneous upper/lower ON prevention circuit to prevent arm shorting through simultaneous ON input for the upper and lower side transistors. (Dead time is required for preventing shorting due to switching delay.)
- SIP (The single in-line package) of the transfer full mold structure.

## 4. Absolute maximum ratings at $T_c=25$

Parameter	Symbol	Ratings	Unit	Remarks
Supply voltage	VCC	500	V	+ to - pins, surge<600V
Collector-emitter voltage	VCE	600	V	+ to U(V,W) or U(V,W) to -, No operating.
Output current	IO	± 10	A	+, -, U, V, W terminal current
Output peak current	IOP	± 15	A	+, -, U, V, W terminal current PW=100uSec
Pre-driver supply voltage	VD1,2,3,4	20	V	VB1 - U, VB2 - V, VB3 - W, VDD - VSS *
Input signal voltage	VIN	0 to 7	V	HIN1,2,3,LIN1,2,3 terminal
FAULT terminal voltage	VFAULT	20	V	FAULT terminal
Maximum loss	Pd	15	W	Per 1 channel
Junction temperature	Tj	150		IGBT,FRD junction temperature
Storage temperature	Tstg	-40 to +125		
Operating temperature	TC	-20 to +100		H-IC case temperature
Mounting torque		1.0	Nm	A screw part

In the case without the instruction, the voltage standard is – terminal = VSS terminal voltage.

\* VD1 = between VB1-U , VD2 = VB2-V , VD3 = VB3-W , VD4 = VDD-VSS , terminal voltage.

**5 . Electrical Characteristics at Tc=25 , VD=15V**

Parameters	Symbols	Conditions	Test Circuit	Ratings			Unit	
				Min.	Typ.	Max.		
Power output part								
Collector-to-emitter cut-off current	I CE	V CE=600V	Fig.1			2	mA	
Collector-to-emitter saturation voltage	VCE(SAT)	Io=5A	Upper Side	Fig.2		2.2	3.0	V
			Lower Side			2.4	3.2	V
Diode forward voltage	V F	Io=-5A	Upper Side	Fig.3		1.6	2.5	V
			Lower Side			1.8	2.7	V
Junction-to-substrate thermal resistance	j-c(T)	IGBT		-	7.0		/W	
	θj-c(D)	FWD	-	-	8.0	-		
Control (Pre-driver) part								
Control power supply consumption electric current	I D	V D1,2,3=15V	Fig.4		0.05	1	mA	
		V D4=15V			2	10		
Input ON voltage	V IH	Output ON				0.8	V	
Input OFF voltage	V IL	Output OFF		3.0			V	
Protection part								
Overcurrent protection electric current	I SD	PW=100 μ s	Fig.5	10		18	A	
Pre-drive power supply low voltage protection	UVSD		-	10		12	V	
Fault terminal input electric current	I OSD	VFAULT=1.0V	-	-	2		mA	
Fault clearness delay time	FLTCLR	Each after protection operation ending	-	6	9	12	ms	
Switching time	t ON	IO=5A, Inductive Load	Fig.6	0.5	1.0		μ s	
	t OFF				1.0	2.0		
Electric current output signal level	I SO	IO=5A		0.158	0.167	0.176	V	

In the case without the instruction, the voltage standard is - terminal = VSS terminal voltage.

**Notes**

- Input ON voltage indicates a value to turn on output stage IGBT. Input OFF voltage indicates a value to turn off output stage IGBT. At the time of output ON, set the input signal voltage 0V to V IH (MAX). At the time of output OFF, set the input signal voltage V IL (MIN) to 5V.
- When the internal protection circuit operates, there is FAULT signal ON (When the FAULT terminal is low level, FAULT signal is ON state : output form is open DRAIN) but the FAULT signal doesn't latch. After protection operation ending, it returns automatically within about 9 ms and it becomes an operation beginning condition. So, after FAULT signal detection, set OFF (High) to all

---

input signals at once. But, the operation of pre-drive power supply low voltage protection (UVLO: it has a hysteresis about 0.3V) is as follows. Upper side There is not FAULT signal output but it does a corresponding gate signal OFF. Incidentally, it returns to the regular operation when recovering to the normal voltage but the latch continues among input signal ON (Low). Lower side

It outputs FAULT signal with gate signal OFF. However, it different from the protection operation of upper side, it is automatically reset about 9 ms later and becomes an operation beginning condition when recovering to the normal voltage. (The protection operation doesn't latch by the input signal.)

- 3 . When assembling the hybrid IC on the heat sink, tightening torque range is 0.8N · m to 1.0N · m.
- 4 . The pre-drive low voltage protection is the feature to protect a device when the pre-driver supply voltage declines with the operating malfunction. As for the pre-driver supply voltage decline in case of operation beginning, and so on, we request confirmation in the set.

6. Circuit Block Diagram

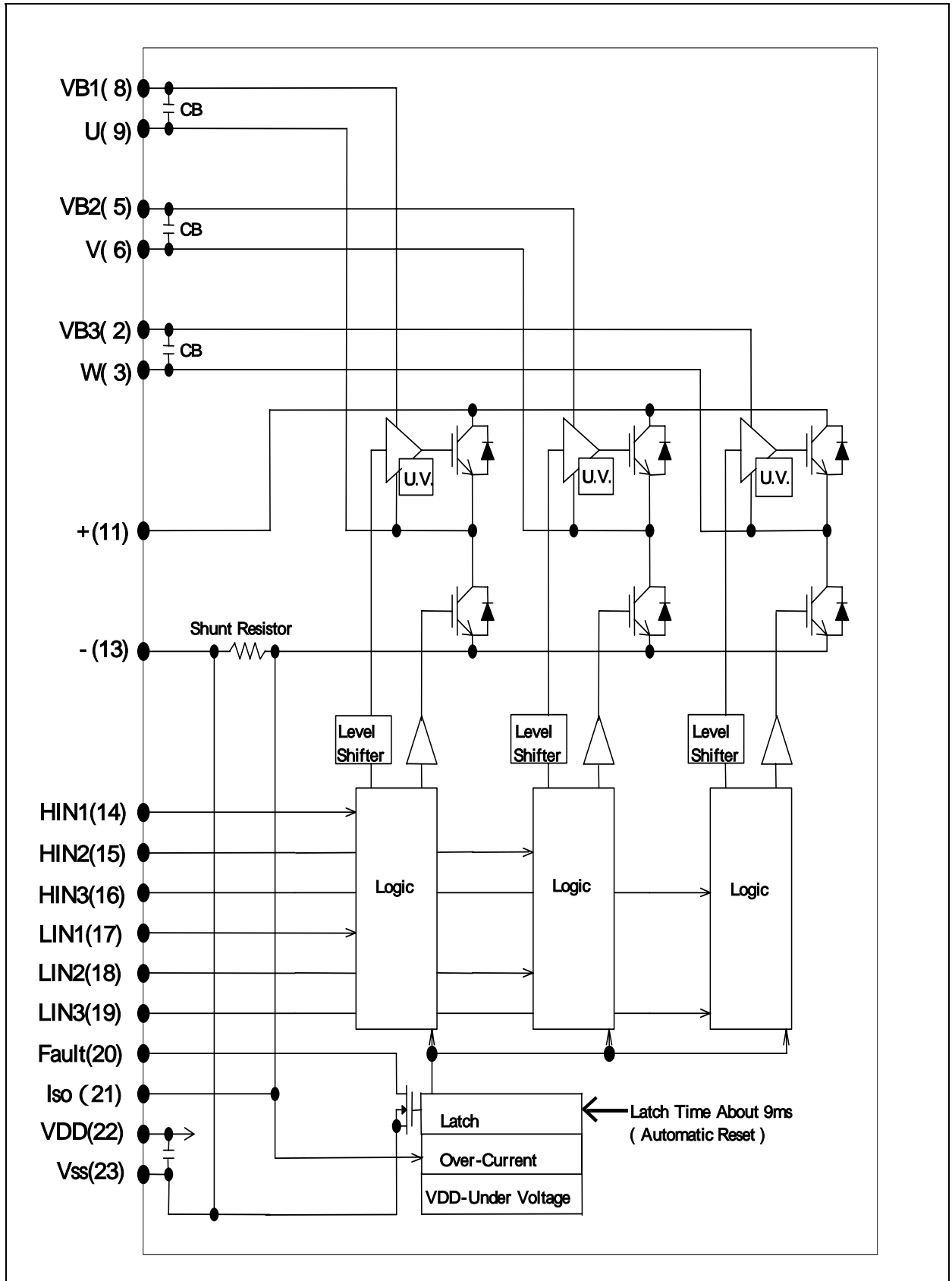

**7. Test Circuit**

Fig 1 : I<sub>CE</sub>

	U+	V+	W+	U-	V-	W-
M	11	11	11	9	6	3
N	9	6	3	13	13	13

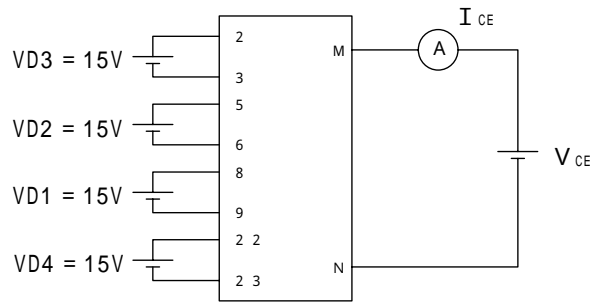

Fig 2 : V<sub>CE(SAT)</sub>

	U+	V+	W+	U-	V-	W-
M	11	11	11	9	6	3
N	9	6	3	13	13	13
m	14	15	16	17	18	19

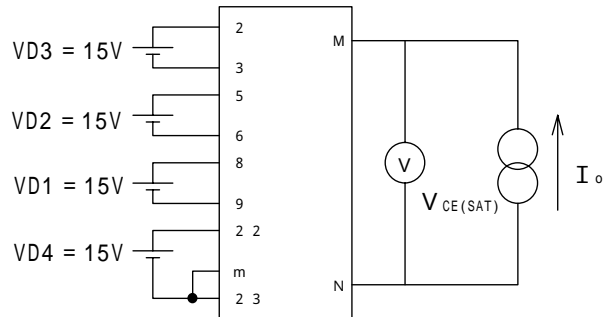

Fig 3 : V<sub>F</sub>

	U+	V+	W+	U-	V-	W-
M	11	11	11	9	6	3
N	9	6	3	13	13	13

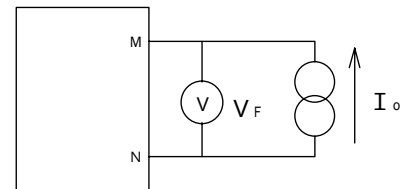

Fig 4 : I<sub>D</sub>

	VD1	VD2	VD3	VD4
m	8	5	2	22
n	9	6	3	23

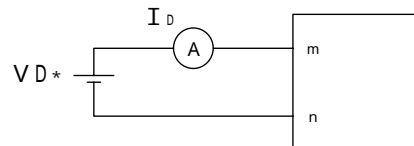

Fig 5 : I SD

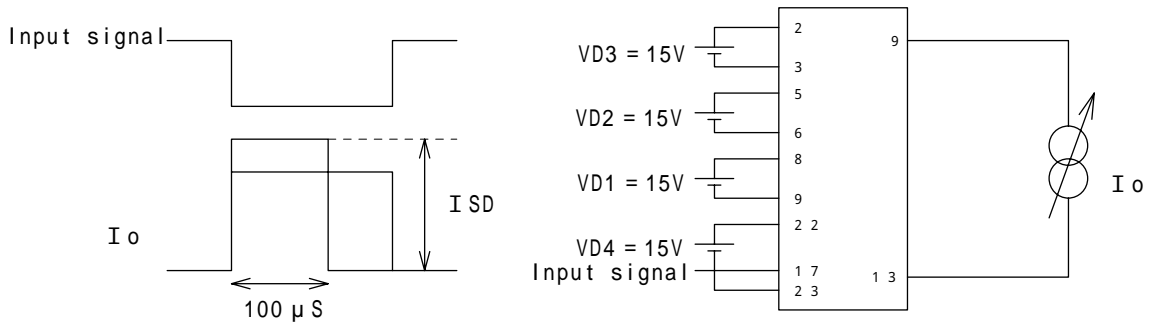
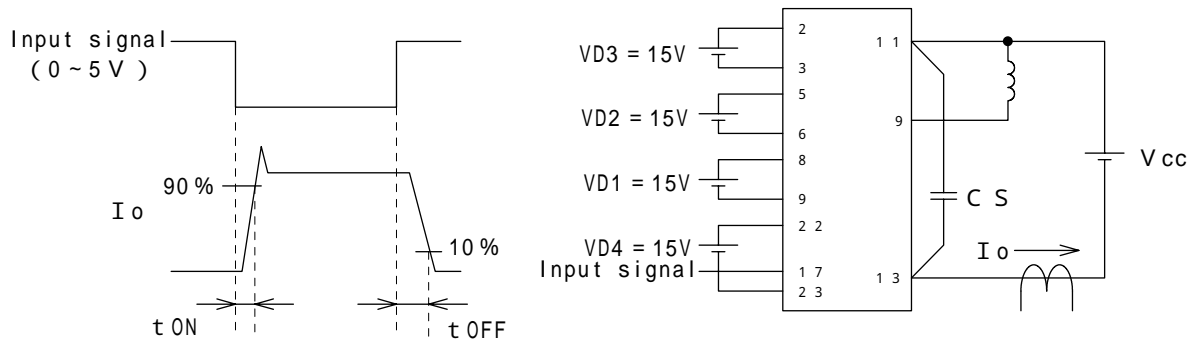
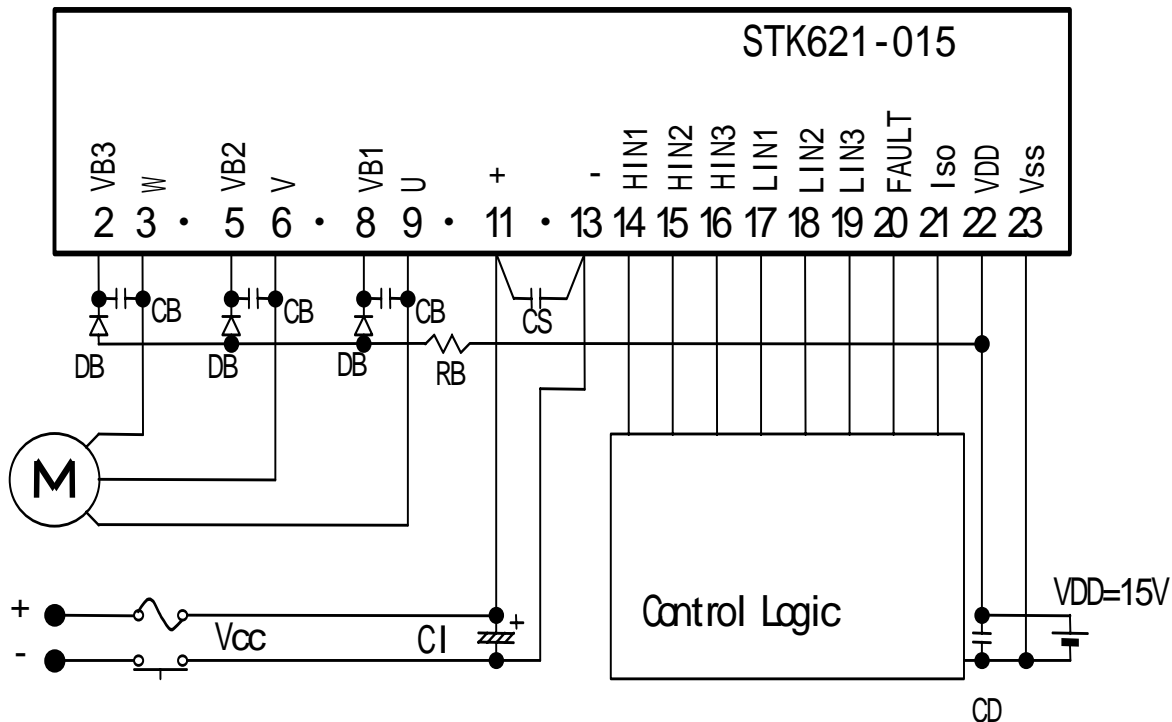

Fig 6 : Switching Time



8. Example of the application circuit



9. Recommendation Operating Conditions

Parameters	Symbol	Conditions	Value			Unit
			Min.	Typ.	Max.	
Supply voltage	Vcc	+ - -	0	280	400	V
Pre-driver supply voltage	VD1,2,3	VB1 - U,VB2 - V,VB3 - W	12.5	15	17.5	V
	VD4	VDD - Vss 1	13.5	15	16.5	
Input ON voltage	VIN(ON)	HIN1,HIN2,HIN3,	0	-	0.3	V
Input OFF voltage	VIN(OFF)	LIN1,LIN2,LIN3 Terminal	3.5	-	5	
PWM frequency	fPWM		1	-	20	KHZ
Deadtime	DT	Upper/lower input signal downtime	2	-	-	μs
Tightening torque	MT	' M 3 ' Type Screw	0.8	-	1.0	N·m

1 Pre-drive power supply (VD4=15 ± 1.5V) must have the capacity of Io=20mA(DC), 0.5A(Peak).

Usage Precautions

- By the addition of the diode for the bootstrap (DB : high speed type, withstand voltage equal to or more than 600V) and of the capacitor (CB : about 1 to 47 μ F), a single power supply drive is enabled. In this case, it makes a lower side IGBT ON (input signal of lower side makes LOW). Then it charges

---

in CB. Incidentally, in case of start-up and so on, when the voltage of CB is low, the big charging electric current flows and sometimes becomes the cause which exerts the bad influence of the noise and so on. Put limitation resistance RB (Several  $\Omega$  to about tens of  $\Omega$ ). (When not using bootstrap circuit, each upper side pre-drive power supply needs an independent power supply. Externally set.) Also, the upper side power supply voltage sometimes declines by the way of controlling. Confirm it.

2. Because the jump voltage which is accompanied by the vibration in case of switching operation occurs by the influence of the floating inductance of the wiring of the outer power supply which is connected with of the + terminal and the -terminal, restrains and spares surge voltage being as the connection of the snubber circuit (Capacitor / CS / about 0.1 - 10  $\mu$ F) for the voltage absorption with the neighborhood as possible between + and the - terminal, and so on, with making a wiring length (among the terminals each from CI) short and making a wiring inductance small.
3. Iso terminal (20pin) is for the electric current monitor. Be careful, because the overcurrent protection does not operate when short-circuiting in the Iso terminal and the Vss terminal.
4. Output form of the FAULT terminal is open DRAIN (it is operating as FAULT when becoming LOW). When the pull up with the resistance, use above 5.6K $\Omega$ .
5. Zener diode with 5V (5.0-5.4V) is connected with the inside of the signal input terminal. When inputting the voltage which exceeds 5 V, connect resistor to between the side of the power and the signal input terminal, for the input current of the signal input terminal become equal to or less than 0.5mA. This resistor is effective with the noise absorption of the signal terminal, too.
6. The overcurrent protection feature operates only when it is possible to do a circuit control normally. For the safety, put a fuse, and so on in the Vcc line.
7. Because the IC sometimes destroys and bursts when motor connection terminal (3pin,6pin,9pin) becomes open while the motor turns, especially, be careful of the connection ( the soldering condition ) of this terminal.

This data shows the example of the application circuit, does not guarantee a design as the mass production set



# PACKAGE DIMENSION

SCALE	1/1	UNIT	mm
-------	-----	------	----

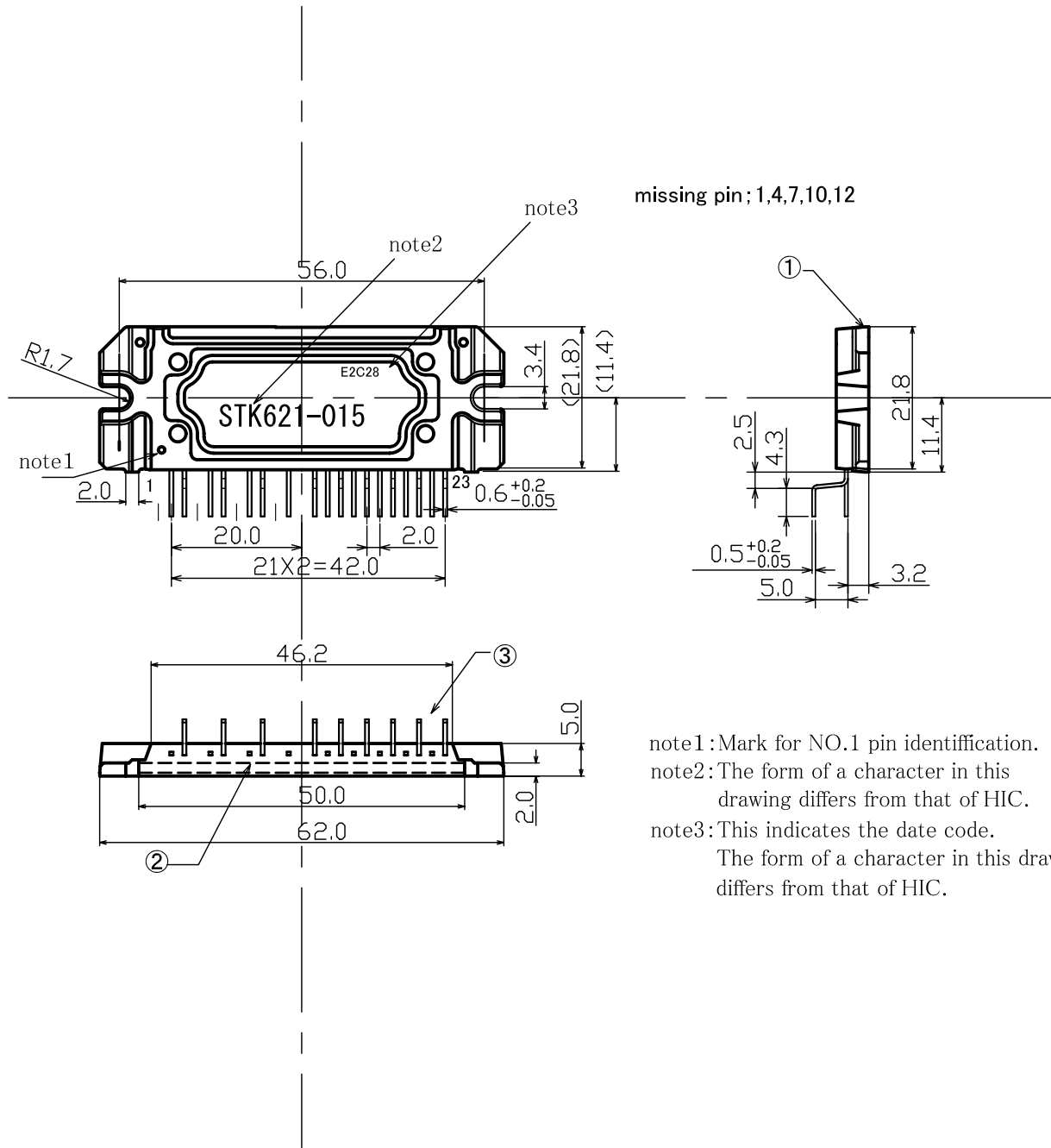

note1 : Mark for NO.1 pin identification.  
 note2 : The form of a character in this drawing differs from that of HIC.  
 note3 : This indicates the date code.  
 The form of a character in this drawing differs from that of HIC.

	PARTS NAME	MATERIAL	TREATMENT
①	CASE	EPOXY	
②	SUBSTRATE	IMST SUBSTRATE	
③	LEAD FRAME	Cu	COPPER/SOLDER PLATING

DO NOT SCALE THIS DRAWING

TOLERANCE UNLESS OTHERWISE SPECIFIED ±0.5

DRAWN.		DATE	Mar. /28/2002	NAME	STK621-015	PART NO.	
CHECK.		APPRO.		OUTLINE			