



*File Name : ES8310*

*Total Pages : 13*

## **16 位稳态电流 LED 驱动器**

## 16 位稳态电流 LED 驱动器

### 概述

ES8310 IC 是一种稳态电流驱动器。其稳态电流值可以通过调节一外部电阻而变化 ( $I_{out}=5\sim 90\text{mA}$ )。在单晶硅 CMOS 芯片上器件包含有 16 位移位寄存器, 锁存器以及稳态电流驱动器。

### 特征

- 1.输出稳态电流: 通过调节电阻, 其电流变化范围为 5~90 m A
- 2.最大时钟频率: 25MHZ
- 3.兼容 5V CMOS 输入
- 4.封装形式: SDIP24 SSOP24,SOP24
- 5.稳态电流: ( $T_a=25^\circ\text{C}$ ,  $V_{DD}=5.0\text{V}$ )  
Bit-to-Bit:  $\pm 3\%$ ;  
Chip-to-Chip:  $\pm 6\%$
- 6.与 TOSHIBA TB62706 功能及引脚均兼容

## 脚位说明

脚位号	脚位名称	功能
1	GND	控制逻辑的接地端
2	SERIAL-IN	移位寄存器的 SERIAL 数据输入端
3	CLOCK	移位数据时钟上升沿有效
4	$\overline{\text{LATCH}}$	数据锁存输入端。LATCH 端高电平输入时，锁存器传递数据；LATCH 端低电平输入时，锁存器保持数据。
5~20	$\overline{\text{OUT 0~15}}$	输出端
21	$\overline{\text{ENABLE}}$	输出使能输入端。ENABLE 端高电平输入时，所有的输出端关闭，ENABLE 端低电平输入时，所有的输出端开启。
22	SERIAL-OUT	串行输入数据输出端，提供下一级的串行数据输入端
23	R-EXT	调节输出电流的电阻输入端
24	V <sub>DD</sub>	5 V 供应电源端

## 脚位图(顶视图)

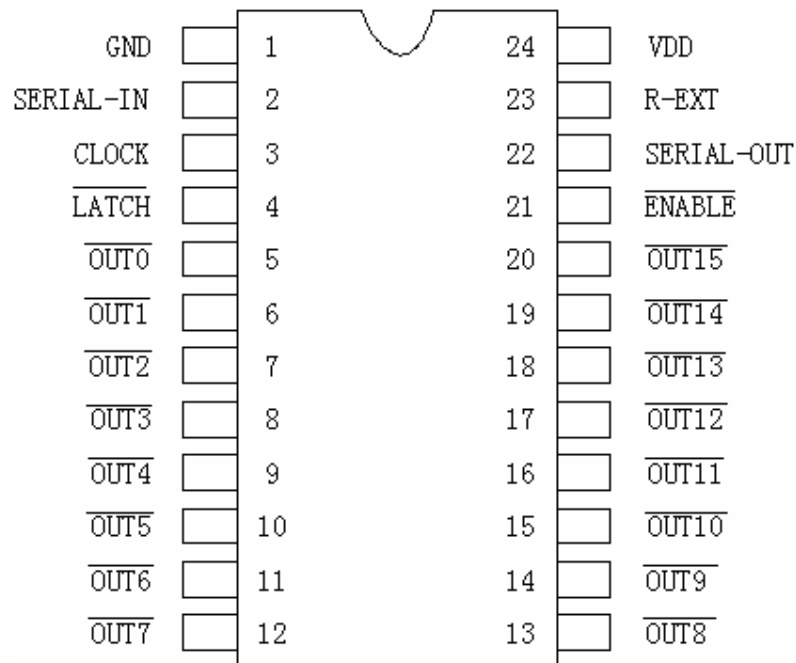

功能方块图

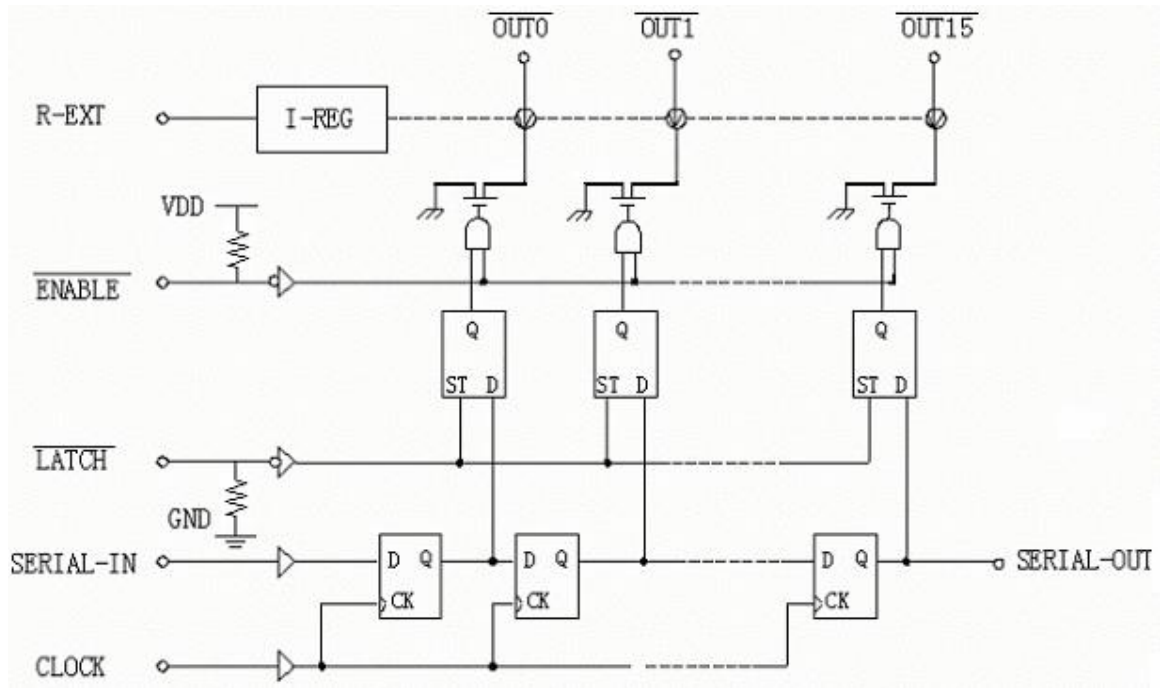

## 时序图

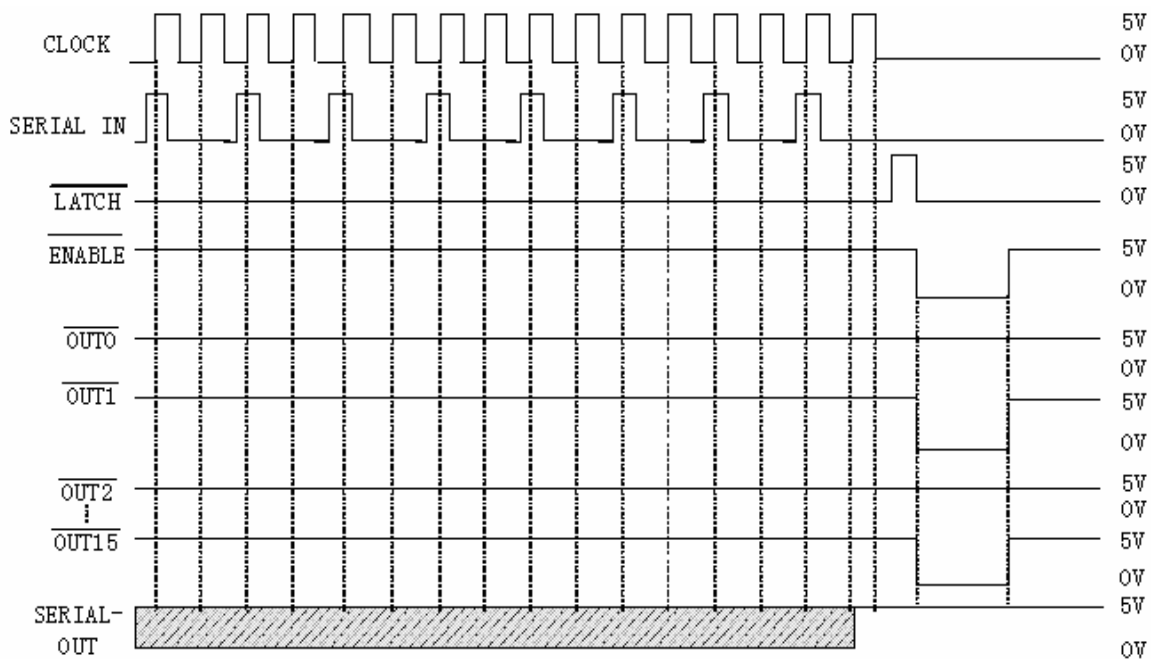

## 注释:

- 1、 $\overline{\text{LATCH}}$ =高电平，锁存器无效，传递数据
- 2、 $\overline{\text{LATCH}}$ =低电平，锁存数据
- 3、 $\overline{\text{ENABLE}}$  高电平时，所有的输出端关闭，呈高阻状态
- 4、在 R-EXT 和 GND 之间串一外接电阻可调整所有输出电流
- 5、数据传输在时钟上升沿有效

输入及输出等效电路

1.ENABLE TERMINAL

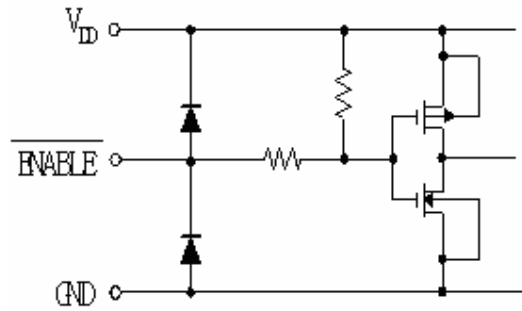

2.LATCH TERMINAL

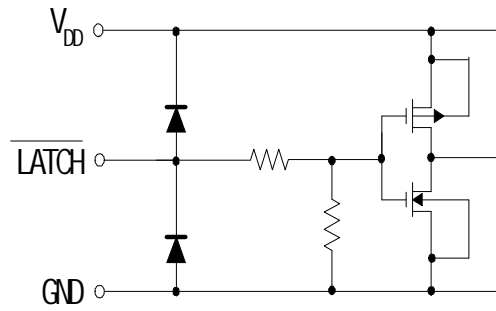

3.CLOCK, SERIAL-IN TERMINAL

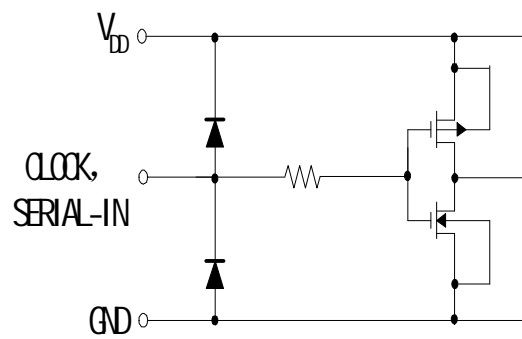

4.SERIAL-OUT TERMINAL

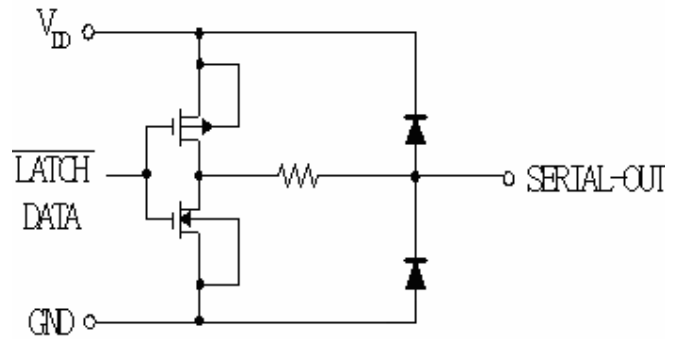

测试电路

直流特性

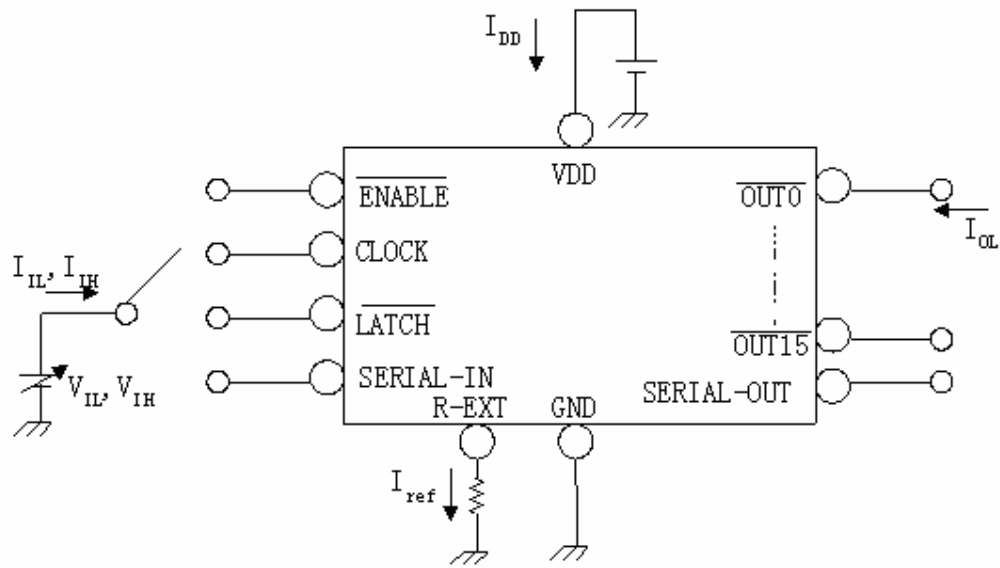

交流特性

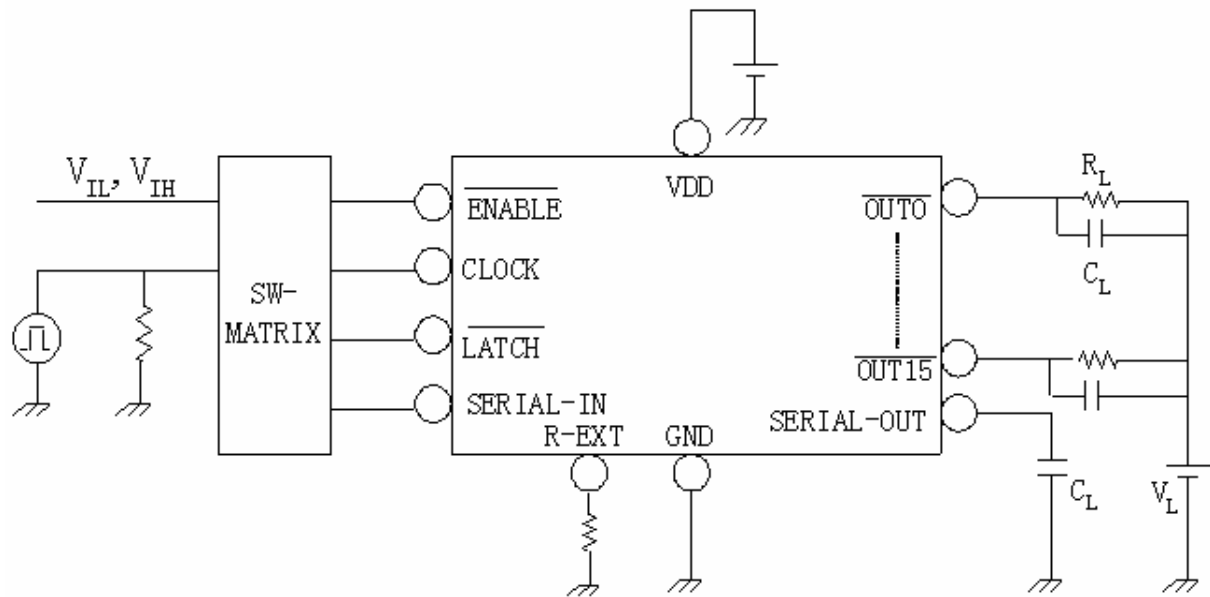

时序的波形图

1. CLOCK-SERIAL-IN, SERIAL-OUT,  $\overline{\text{OUTn}}$

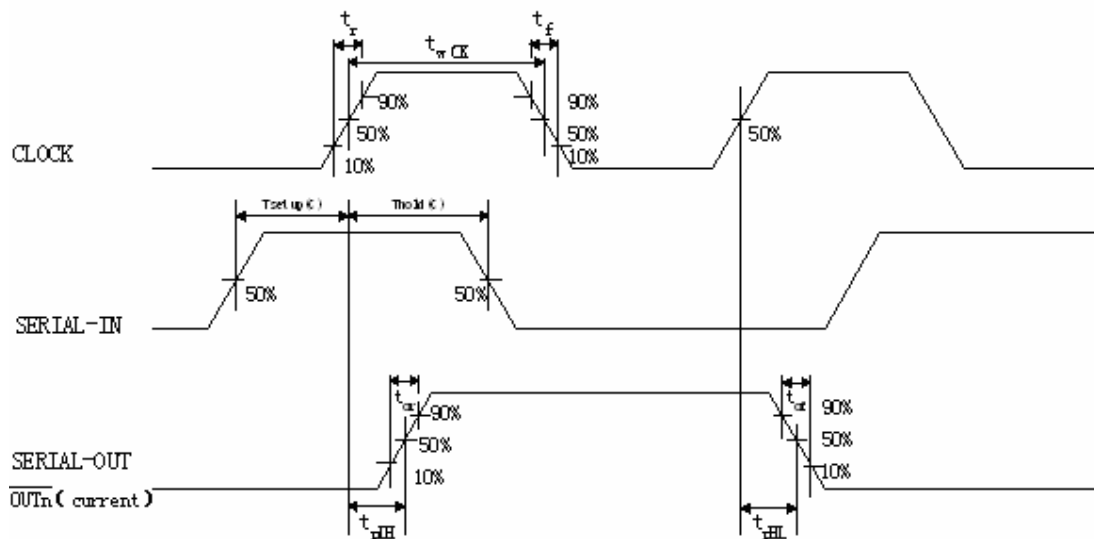

2. CLOCK-LATCH

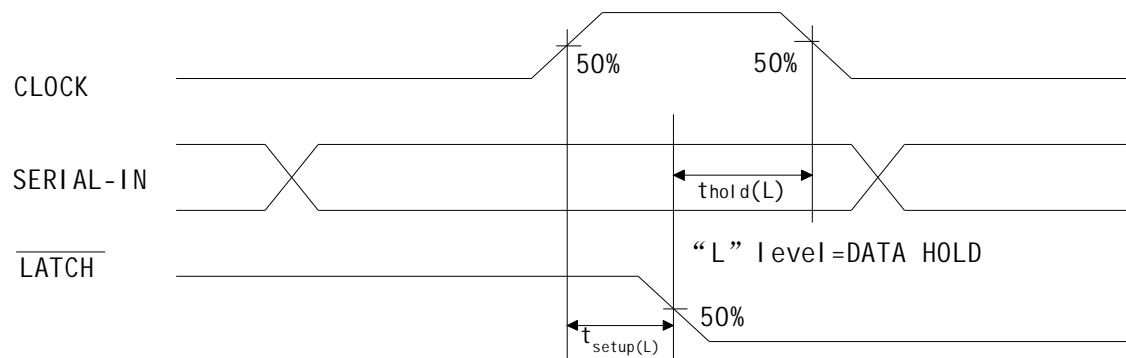

3. ENABLE - $\overline{\text{OUTn}}$

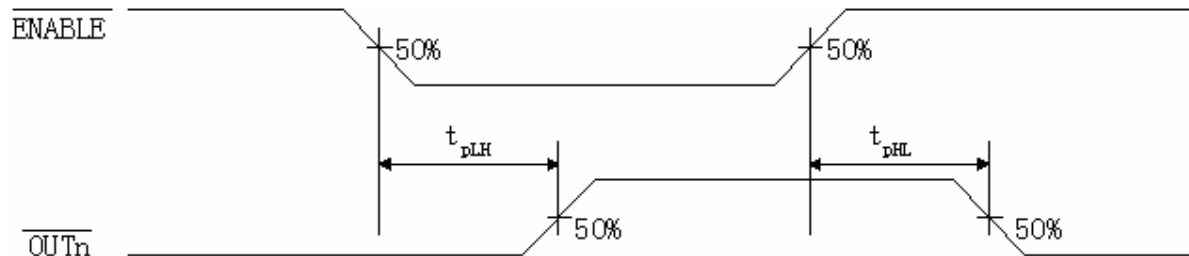



## 电子特性

CHARACTERISTIC	SYMBOL	CONDITION	MIN.	TYP.	MAX.	UNIT
Input Voltage “H” Level	$V_{IH}$	$T_a=-40\sim 85\text{ }^\circ\text{C}$	0.7VDD	—	VDD	V
Input Voltage “L” Level	$V_{IL}$	$T_a=-40\sim 85\text{ }^\circ\text{C}$	GND	—	0.3VDD	
Output Leakage Current	$I_{OH}$	$V_{OH}=15.0\text{V}$	—	—	10	$\mu\text{A}$
Output Voltage (S-OUT)	$V_{OL}$	$I_{OL}=4.0\text{mA}$	—	—	0.4	V
	$V_{OH}$	$I_{OH}=-3.9\text{mA}$	4.6	—	—	
Output Current 1	$I_{OL1}$	$V_{DS}=0.7\text{V}$ $R_{EXT}=470\Omega$ (include Current Matching)	34.1	40.0	45.9	mA
	$I_{OL2}$	$V_{DS}=0.4\text{V}$ $R_{EXT}=470\Omega$ (include Current Matching)	33.7	39.5	45.3	
Output Current 2	$I_{OL3}$	$V_{DS}=0.7\text{V}$ $R_{EXT}=250\ \Omega$ (include Current Matching)	64.2	72.5	80.8	mA
	$I_{OL4}$	$V_{DS}=0.4\text{V}$ $R_{EXT}=300\ \Omega$ (include Current Matching)	50.0	57.0	64.0	
Supply Voltage Regulation	% / VDD	$R_{EXT}=470\ \Omega$ , $T_a=-40\sim +85\text{ }^\circ\text{C}$	—	$\pm 1.5$	$\pm 5.0$	% / V
Pull-Up Resistor	RIN (up)	—	150	300	600	$\text{K}\ \Omega$
Pull-Down Resistor	RIN (down)	—	100	200	400	$\text{K}\ \Omega$
Supply Current “OFF”	$I_{DD(off)1}$	R-EXT=OPEN, $\overline{\text{OUT0}}\sim\overline{7}=\text{off}$	—	0.4	—	mA
	$I_{DD(off)2}$	R-EXT=470 $\Omega$ , $\overline{\text{OUT0}}\sim\overline{7}=\text{off}$	—	4.3	—	
	$I_{DD(off)3}$	R-EXT=250 $\Omega$ , $\overline{\text{OUT0}}\sim\overline{7}=\text{off}$	8.0	8.3	8.5	
Supply Current “ON”	$I_{DD(on)1}$	R-EXT=470 $\Omega$ , $\overline{\text{OUT0}}\sim\overline{7}=\text{on}$	4.2	4.4	4.7	mA
	$I_{DD(on)2}$	R-EXT=250 $\Omega$ , $\overline{\text{OUT0}}\sim\overline{7}=\text{on}$	8.1	8.4	8.8	

## 最大工作范围

CHARACTERISTIC	SYMBOL	RATING	UNIT
Supply Voltage	$V_{DD}$	0~7.0	V
Input Voltage	$V_{IN}$	-0.4~VDD+0.4	V
Output Current	$I_{OUT}$	+90	mA
Output Voltage	$V_{OUT}$	-0.5~+17.0	V
Clock Frequency	$f_{CLK}$	25	MHz
GND Terminal Current	$I_{GND}$	1440	mA
Power Dissipation	$P_D$	1.78(SDIP-24: ON PCB Ta=25°C)	W
		1.00(SSOP-24: ON PCB Ta=25°C)	
Thermal Resistance	$R_{th(j-a)}$	70.0(SDIP-24: ON PCB)	°C/W
		120(SSOP-24: ON PCB)	
Storage Temperature	$T_{stg}$	-55~+150	°C
Operating Temperature	$T_{opr}$	-40~+85	°C

## 转换特性

CHARACTERISTIC		SYMBOL	CONDITION	MIN.	TYP.	MAX.	UNIT	
Propagation Delay Time ("L" to "H")	CLK-OUTn	$t_{pLH}$	$V_{DD}=5.0V$ $V_{CE}=0.4V$ $V_{IH}=V_{DD}$ $V_{IL}=GND$ $R_{EXT}=470\ \Omega$ $V_L=3.0V$ $R_L=65\ \Omega$ $C_L=10.5pF$	—	1200	1500	ns	
	LATCH/-OUTn/			—	1200	1500		
	ENABLE/-OUTn/			—	1200	1500		
	CLK - S-OUT			—	30	70		
Propagation Delay Time ("H" to "L")	CLK-OUTn	$t_{pHL}$		$V_{DD}=5.0V$ $V_{CE}=0.4V$ $V_{IH}=V_{DD}$ $V_{IL}=GND$ $R_{EXT}=470\ \Omega$ $V_L=3.0V$ $R_L=65\ \Omega$ $C_L=10.5pF$	—	700	1000	ns
	LATCH/-OUTn/				—	700	1000	
	ENABLE/-OUTn/				—	700	1000	
	CLK - S-OUT				—	30	70	
Output Current Rise Time		$t_{or}$			150	300	600	ns
Output Current Fall Time		$t_{of}$			150	300	600	ns

建议操作条件

CHARACTERISTIC	SYMBOL	CONDITION	MIN.	TYP.	MAX.	UNIT
Supply Voltage	V <sub>DD</sub>	—	4.5	5.0	5.5	V
Output Voltage	V <sub>OUT</sub>	—	—	—	15.0	V
Output Current	I <sub>OUT</sub>	DC 1 Circuit	5	—	88	mA
	I <sub>OH</sub>	SERIAL-OUT	—	-3.7	—	
	I <sub>OL</sub>	SERIAL-OUT	—	-4.0	—	
Input Voltage	V <sub>IH</sub>	—	0.7V <sub>DD</sub>	—	V <sub>DD</sub> +0.3	V
	V <sub>IL</sub>	—	-0.3	—	0.3V <sub>DD</sub>	
LATCH Pulse Width	t <sub>w</sub> LAT	V <sub>DD</sub> =4.5~5.5V	100	—	—	ns
CLOCK Pulse Width	t <sub>w</sub> CLK		50	—	—	ns
Set-up Time for DATA	t <sub>setup</sub> (D)		60	—	—	ns
Hold Time for DATA	t <sub>hold</sub> (D)		20	—	—	ns
Set-up Time for LATCH	t <sub>setup</sub> (L)		100	—	—	ns
Clock Frequency	f <sub>CLK</sub>		Cascade operation	—	15.0	20.0
Power Dissipation	P <sub>D</sub>	Ta=85°C(SDIP-24)	—	—	0.92	W
		Ta=85°C(SSOP-24)	—	—	0.50	

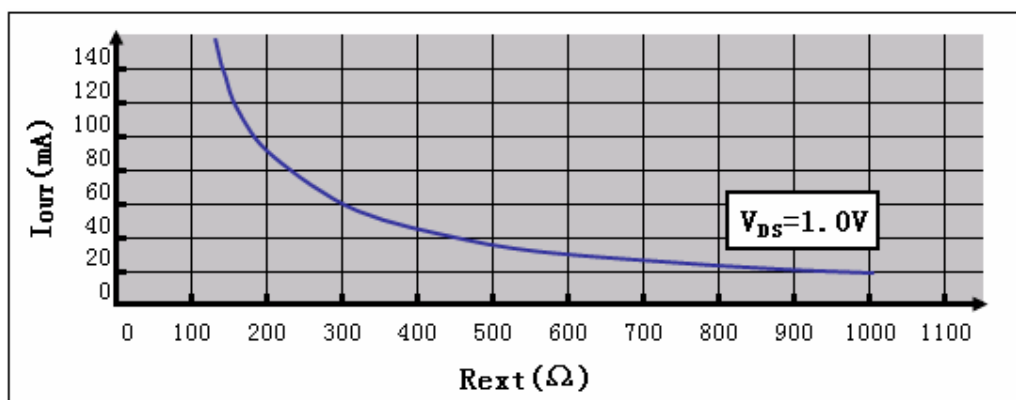
I<sub>OUT</sub>-R-EXT

电流计算公式:  $I_{out} = (1.23/R_{ext}) \times 15.3$

外观轮廓图

SDIP24

UNIT:mm

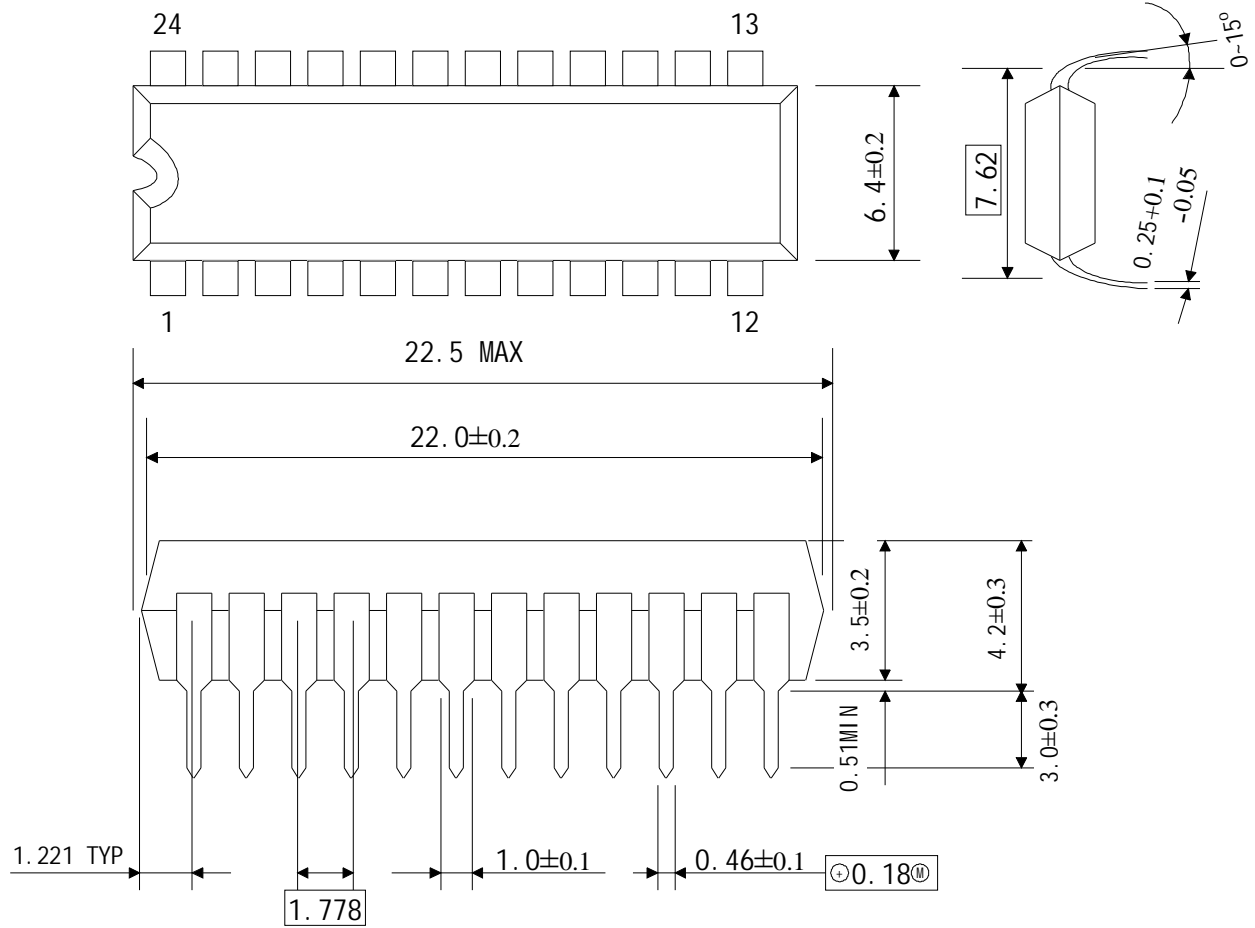

Weight: 1.22g (Typ.)

SOP24

UNIT: mm

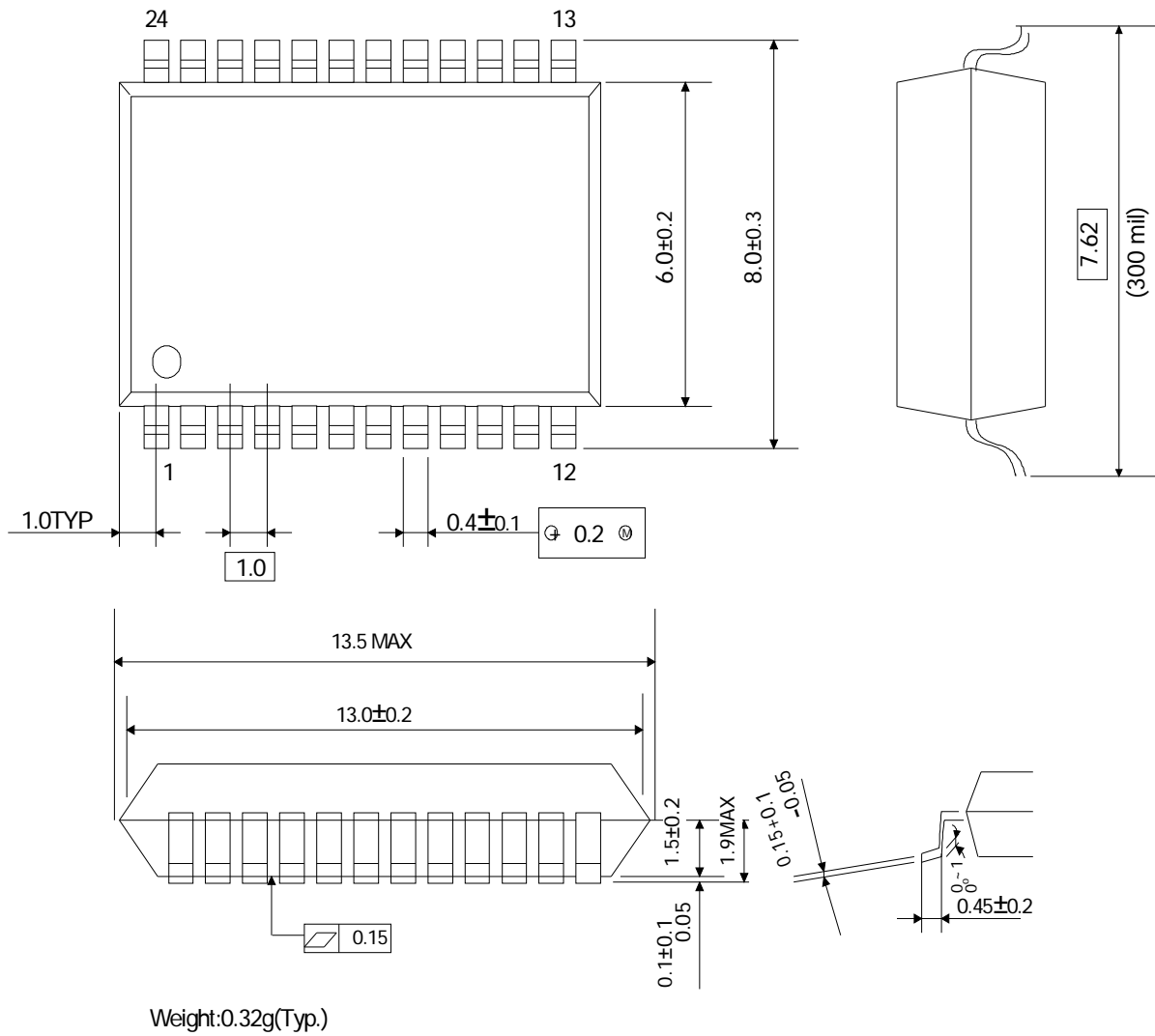

SSOP24

Unit : mm

