

First Member of the *maxVZ* Family

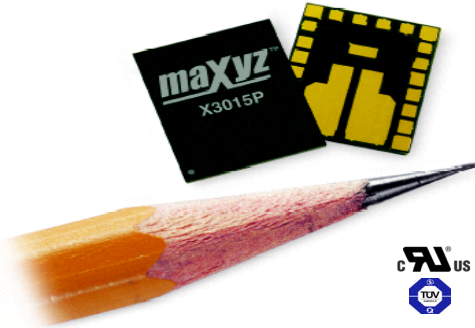

Applications

- Low voltage, high density systems with Intermediate Bus Architectures (IBA) from 3.0V to 6.0V
- Desktops, servers, portable computing
- Broadband, networking, optical and communications systems
- Battery operated equipment
- Point of load regulators for high performance DSP, FPGA, ASIC and microprocessor applications
- Advanced set-top boxes

Benefits

- One part for different input and output voltage ranges
- Reduces complete solution board area
- Reduces discrete parts count by 90%
- Minimal external L and C required
- Can be placed on the bottom of host PCB
- Compatible with conventional pick-and-place equipment

Features

- Fully integrated controller, driver, FETs and passives
- Small footprint surface mount LGA package: 10x12mm
- Wide input low voltage range: 3.0V – 6.0V
- Wide range programmable output: 0.75V – 4.0V
- High continuous output current: 15A
- High current density: 80A/in²
- Efficiency up to 95%
- Remote voltage sense
- Output overcurrent protection
- Remote enable (ON/OFF)
- Programmable fixed frequency operation from 300kHz to 500 kHz
- Frequency synchronization
- Fast load transient response
- Extremely low profile: 1.42mm
- Wide operating temperature range –40 to 115°C
- UL60950 recognized, CSA C22.2 No. 60950-00 certified, and TUV EN60950-1:2001 certified

Description

The X3015P is a highly efficient point-of-load DC/DC power solution designed to deliver low voltages at high currents in close proximity to loads. The X3015P integrates all the required active and passive components in a single LGA package including a synchronous buck PWM controller, driver circuits and two low *R_{dsON}* MOSFETs. This high level of integration reduces the need for multiple external components, allowing for a selection of optimum output filter components. Remote enable, fast transient response and output overcurrent protection are just a few of the integrated features that minimize cost and time to market.

Model	Input Voltage (VDC)	Input Current (ADC)	Output Voltage (VDC)	Output Current (ADC)	Output Ripple and Noise (mV p-p)	Efficiency (5V _{IN} , 3.3V _{OUT} , 15A) (%)
X3015P	3.0 – 6.0	13	0.75 – 4.0	15	25	91.5

1. Absolute Maximum Ratings

Stresses in excess of the absolute maximum ratings may cause performance degradation, adversely affect long-term reliability and cause permanent damage to the converter.

Parameter	Conditions/Description	Min	Max	Units
Operating Junction Temperature	At 100% load	-40	125	°C
Output Current	(See Output Current Derating Curves)		15	ADC
Input Voltage	V _{IN} referenced to Pgnd	-0.3	7.0	VDC
Boost Voltage	V _{BOOST} referenced to Pgnd	-0.3	6.5	VDC
Frequency Adjust Voltage	Freq voltage ref to -V _S	-0.3	V _{IN} +0.3	VDC
Voltage Sense	+V _S to -V _S	-0.3	V _{IN} +0.3	VDC
Enable Voltage	Referenced to -V _S	-0.3	V _{IN} +0.3	VDC
Output Current Adjust Voltage	OCP voltage referenced to -V _S	-0.3	V _{IN} +0.3	VDC
Negative Voltage Sense	Referenced to Pgnd	-0.1	+0.1	VDC

2. Environmental and Mechanical Specifications

Parameter	Conditions/Description	Min	Nom	Max	Units
Mechanical Shock	JESD - B104 - B			1500	g
Sinusoidal Vibration	JESD - B103 - B			20	g
Ambient Temperature Range	Measured on case (T _{CASE})	-40		115	°C
Storage Temperature (T _S)		-55		125	°C
Weight				0.4	grams
MTBF	Per Telcordia TR-NWT-000332		4,052		kHrs
MSL	JEDEC J-STD-020A Level 3		240		°C
Packaging/Storage	JEDEC J-STD-033		Yes		N/A
Shipping / Labeling	JEDEC J-STD-113-B		Yes		N/A
Solderability	J-STD-002 Cat 3		Yes		N/A

3. Electrical Specifications

Refer to the 15A reference design described in Section 5. Specifications apply over specified input voltage, output load and case temperature range of 0 to 115°C, unless otherwise noted.

3.1 Input Specifications

Parameter	Conditions/Description	Min	Nom	Max	Units
Input voltage (V_{IN})	Continuous	3.0		6.0	VDC
	Transient Input Voltage			7.0	VDC
Input Current (at no load)	$V_{IN\ NOM}$, $I_{OUT} = 0A$, enable high		50		mADC
Input Reflected Ripple Current	$V_{IN\ MIN}$, $I_{OUT\ MAX}$ ($Z_{IN} = 5m\Omega$, 10 x 22 μ F ceramic capacitors)			30	mA rms
Undervoltage Lockout	Ramping Up	2.75	2.85	2.95	VDC
	Ramping Down	2.65	2.75	2.9	

3.2 Output Specifications

Parameter	Conditions/Description	Min	Nom	Max	Units
Output Voltage Range (V_{OUT})	User programmable	(0.75) ¹	2.5	4.0	VDC
	$V_{OUT} \leq 0.7V_{IN}$	1.25			
Output Voltage Setpoint Accuracy	(Trim resistors $\leq 0.1\%$ tolerance to optimize setpoint accuracy)	-1.2		+1.2	% V_{OUT}
Output Current (I_{OUT})	$V_{IN\ MIN}$ to $V_{IN\ MAX}$	0		15	ADC
Line Regulation	$V_{IN\ MIN}$ to $V_{IN\ MAX}$		± 0.2		% V_{OUT}
Load Regulation	$I_{OUT\ MIN}$ to $I_{OUT\ MAX}$		± 0.3		% V_{OUT}
Turn-On Time	To Output Regulation Band		15	20	ms
	Rise Time (10% to 90%)		5		ms
Maximum Admissible Output Capacitance	$V_{IN\ MIN}$ to $V_{IN\ MAX}$ $I_{OUT\ MIN}$ to $I_{OUT\ MAX}$			5,000	μ F
Dynamic Regulation Peak Deviation Settling Time	Slew rate 10A/ μ s 50 -100% load step change to 1% error band			5.0	% V_{OUT}
				200	μ s
Output Voltage Ripple & Noise ²	$V_{IN\ MIN}$ to $V_{IN\ MAX}$, $I_{OUT\ MIN}$ to $I_{OUT\ MAX}$, BW=20MHz		25	40	mV p-p
Temperature Coefficient				0.03	% $V_{OUT}/^{\circ}C$
Duty Cycle	Under Steady State Conditions			70	%

¹)Can be set below 1.25V only by using an external voltage reference

²)Dependent on external L and C component values, refer to the 15A reference design

3.3 Protection Specifications

Parameter	Conditions/Description	Min	Nom	Max	Units
Output Overcurrent Protection					
Protection Type		Non-Latching			
Output Current Limit Threshold	Output Current Limit Threshold ¹	115		200	% I _{OUT MAX}

¹)Dependent on output inductor ESR, refer to the 15A reference design

3.4 Feature Specifications

Parameter	Conditions/Description	Min	Nom	Max	Units
Enable					
Converter ON	Enable signal is low or the pin is connected to P _{gnd} – module is OFF	1.5		V _{IN}	VDC
Open Circuit Voltage	V _{enable} is referenced to P _{gnd}			V _{IN}	VDC
Converter OFF	Enable pin is floating			0.75	VDC
Source Current	V _{on/off} is referenced to P _{gnd}			10	μADC
	Enable pin is connected to P _{gnd}				
Output Voltage Trim					
Default Output Voltage	No trim resistor		2.5		VDC
Trim Range	With internal voltage reference	1.25		4.0	VDC
	With external voltage reference	0.75		4.0	VDC
Maximum Output Voltage	I _{OUT MIN} to I _{OUT MAX}			70	%V _{IN}
Switching Frequency Adjustment					
Default Switching Frequency	V _{IN NOM} , I _{OUT MAX}	270	300	330	kHz
Maximum Programmable Switching Frequency	V _{IN NOM} , I _{OUT MAX}	450	500	550	kHz

4. Typical Performance Characteristics

4.1 Turn On and Turn Off via the Input Voltage

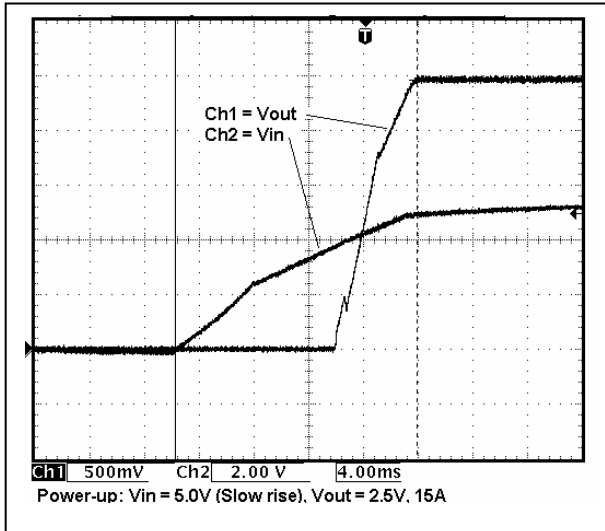

Figure 1. Turn on via Vin (slow rise)

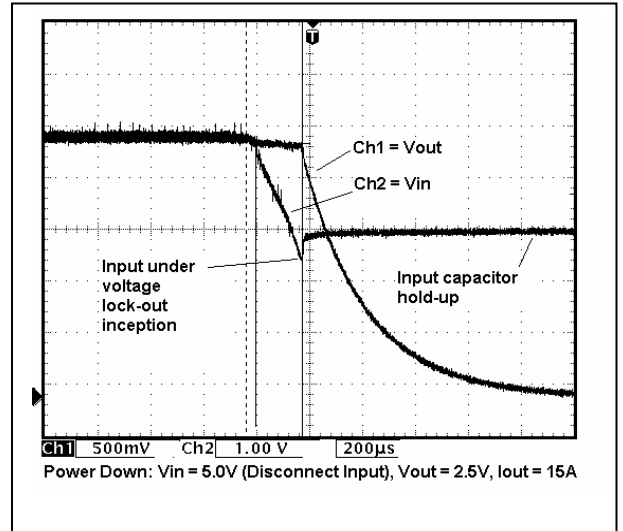

Figure 2. Turn off via Vin

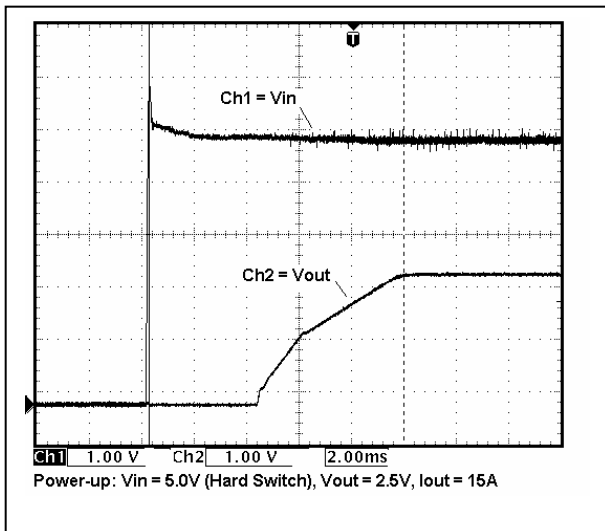

Figure 3. Turn on via Vin (fast rise)

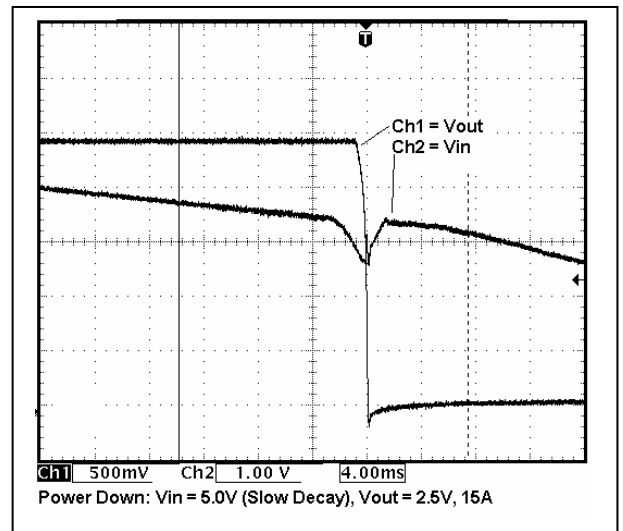

Figure 4. Turn off via Vin (slow decay)

4.2 Turn on and Turn off via Enable Signal

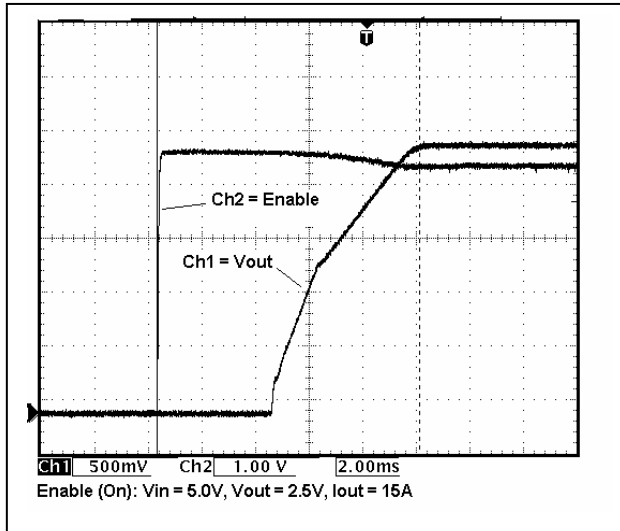

Figure 5. Turn on via Enable signal

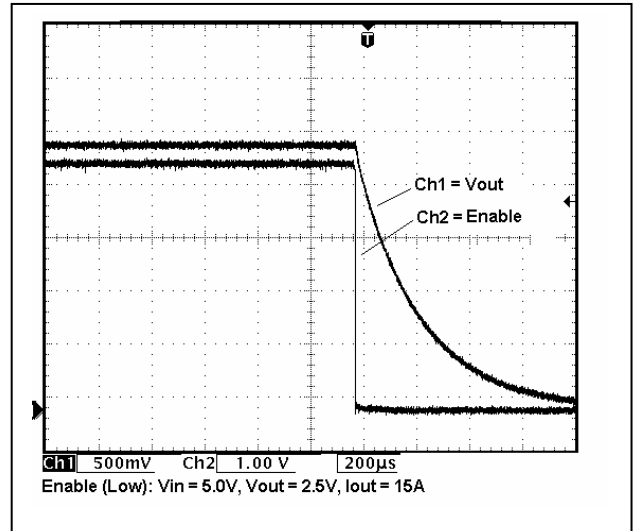

Figure 6. Turn off via Enable signal

4.3 Output Ripple and Noise

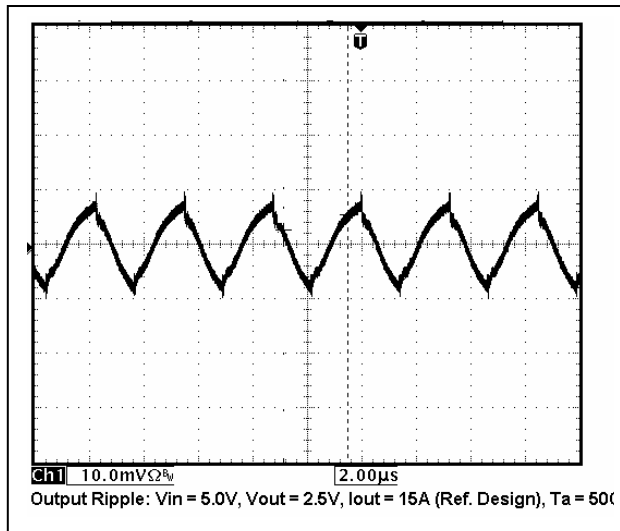

Figure 7. Output Voltage Ripple, Vout=2.5V@15A

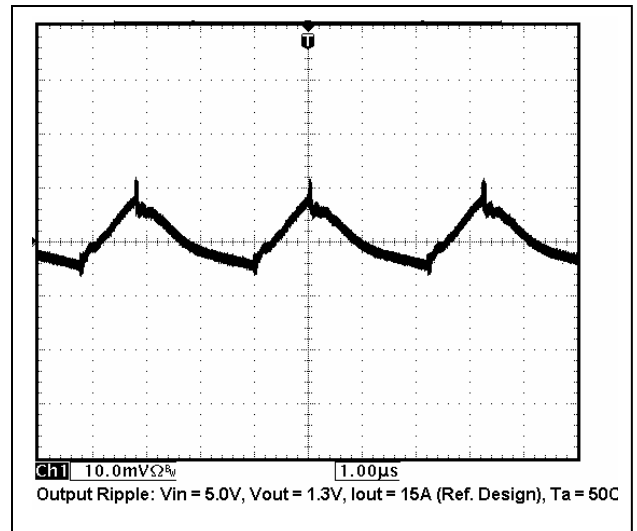

Figure 8. Output Voltage Ripple, Vout=1.3V@15A

4.4 Transient Response

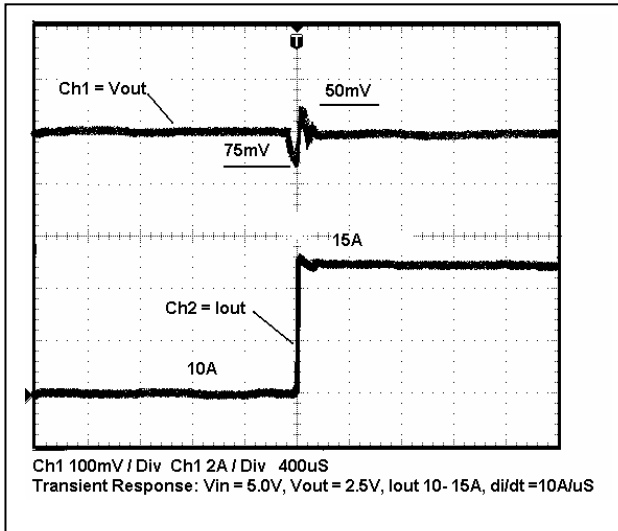

Figure 9. Vout=2.5V, 5A Load Step Change, 10A/μs

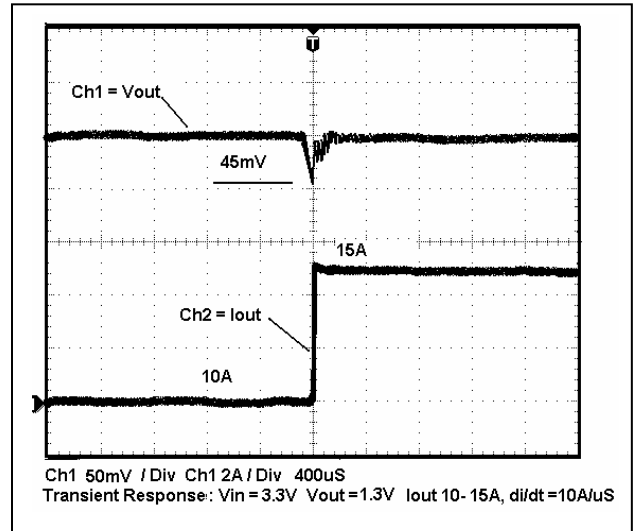

Figure 10. Vout=1.3V, 5A Load Step Change, 10A/μs

4.5 Input Ripple Current

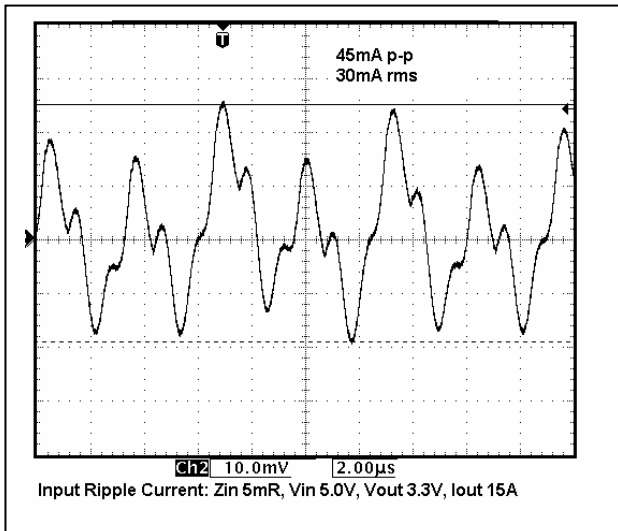

Figure 11. Input Ripple Current, Vin=5V, Vout=3.3V

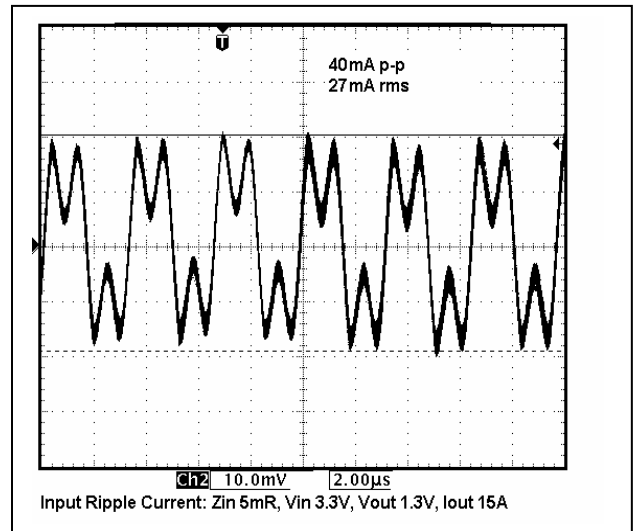

Figure 12. Input Ripple Current, Vin=3.3V, Vout=1.3V

4.6 Output Voltage Regulation and Ripple

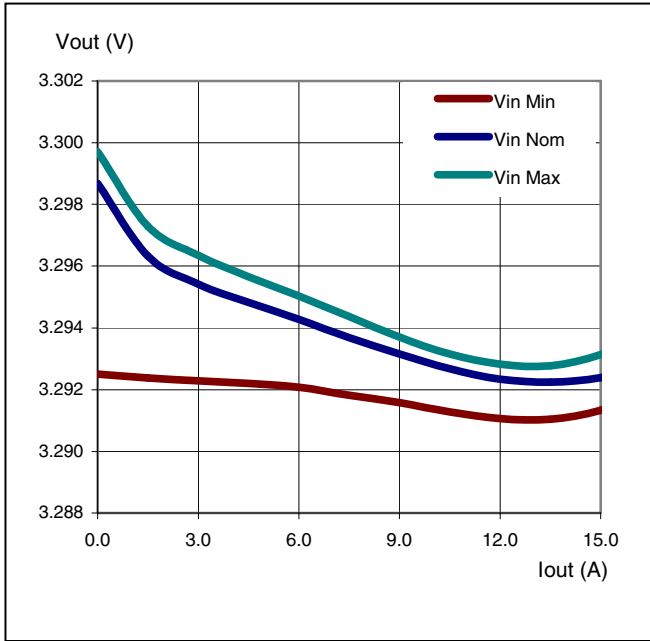

Figure 13. Load Regulation at Vout=3.3V

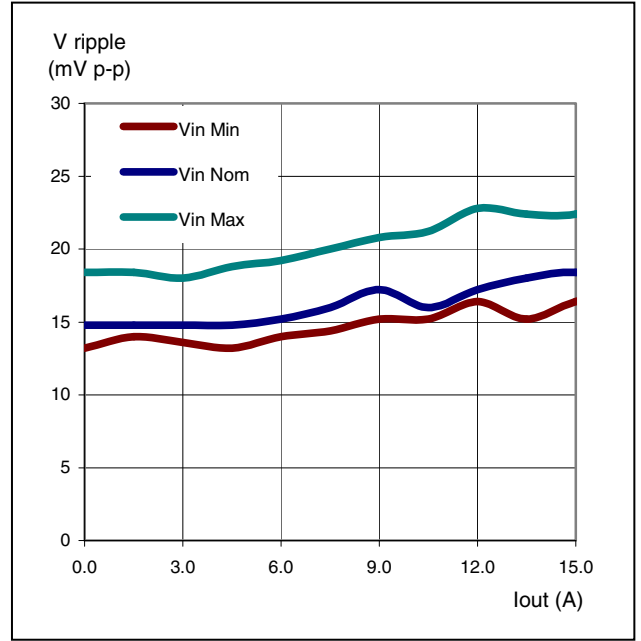

Figure 14. Output Ripple vs. Load at Vout=3.3V

4.7 Efficiency and Power Dissipation

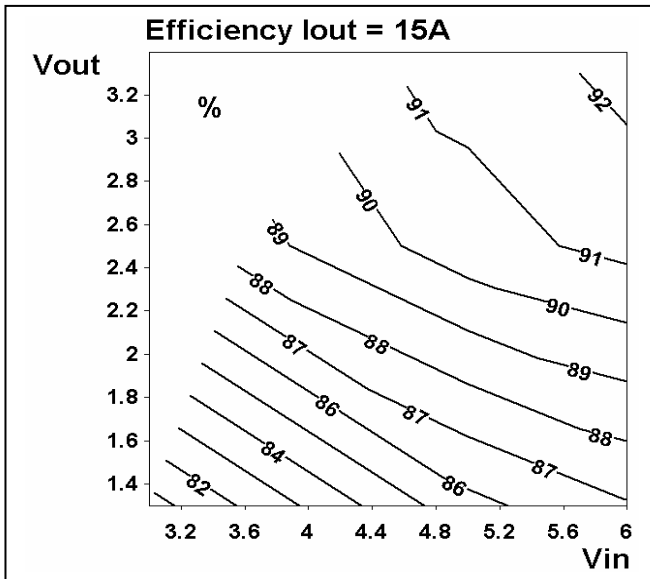

Figure 15. Efficiency vs. Input and Output Voltage

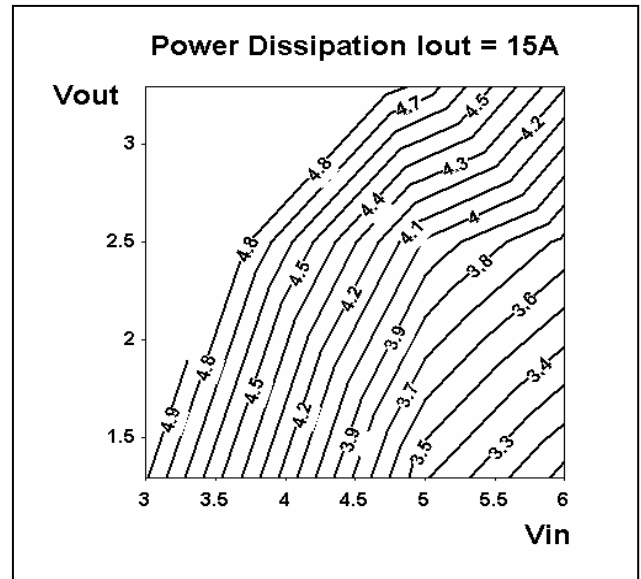

Figure 16. Power Dissipation vs. Input and Output Voltage

5. Typical Application Schematic and BOMs

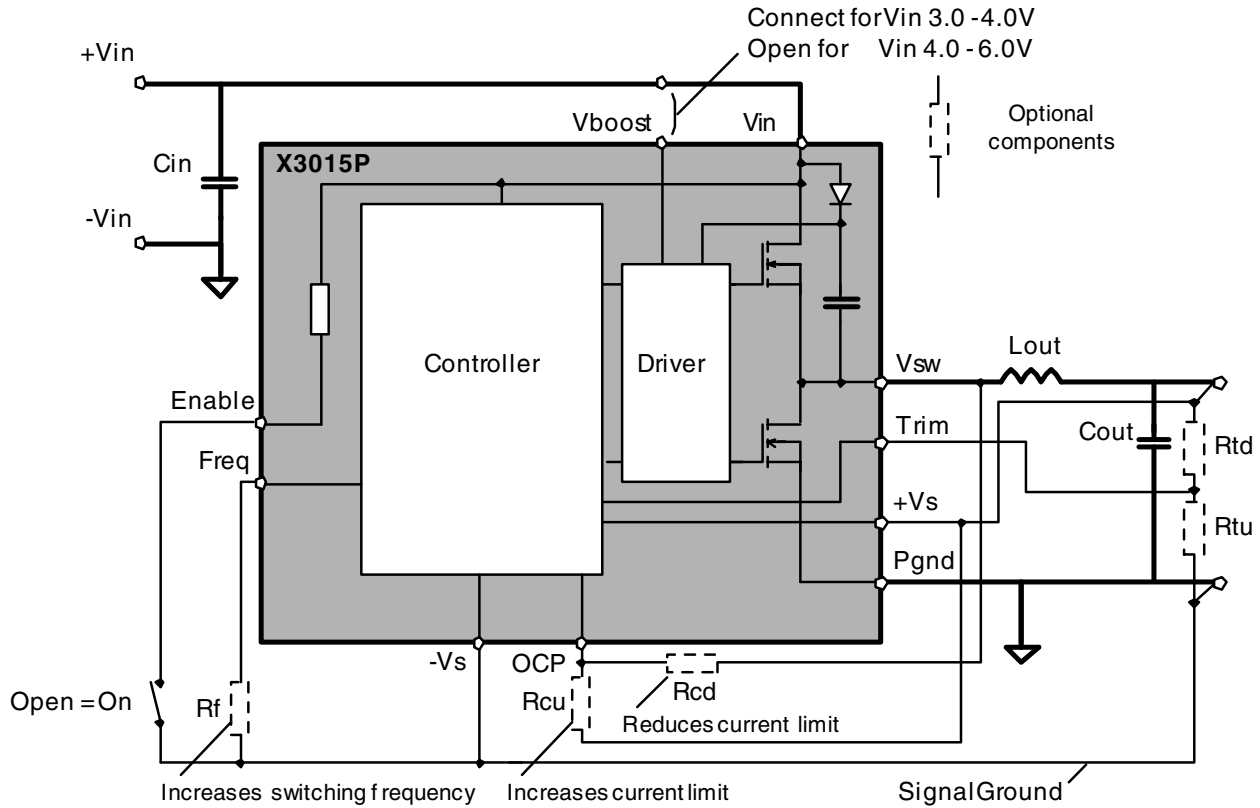

Figure 21. Schematic of Typical Application

Table 1. BOM for 15A Reference Design

Reference Designator	Vendor	Description	Part Number	Qty
C _{OUT}	AVX	330µF/6V Case D	TPSD337M006R0045	4
C _{IN}	Kyocera	10µF X7R 10V 1210	CM32X7R106M10AB	6
L _{OUT}	BI	1.5µH, 18A, ESR 2.3mOhm	HM73-301R5	1
DC-DC Converter	Power-One	15A POL DC-DC converter	X3015P	1
R _{TD} /R _{TU}		Calculated - Output Voltage Trim section	1% resistors	(1)
R _{CD} /R _{CU}		Calculated - Output Current Limit section	1% resistors	(1)
Total Number of Components				12

Table 2. BOM for 7A Reference Design

Reference Designator	Vendor	Description	Part Number	Qty
C _{OUT}	AVX	330µF/6V Case D	TPSD337M006R0045	1
C _{IN}	Kyocera	10µF X7R 10V 1210	CM32X7R106M10AB	3
L _{OUT}	BI	3.9µH, 10A, ESR 7.2mOhm	HM73-303R9	1
DC-DC Converter	Power-One	15A POL DC-DC converter	X3015P	1
R _{TD} /R _{TU}		Calculated - Output Voltage Trim section	1% resistors	(1)
R _{CD} /R _{CU}		Calculated - Output Current Limit section	1% resistors	(1)
R _F		Calculated - Frequency section	1% resistors	(1)
Total Number of Components				6

6. Feature Description

6.1 Enable

This function allows the X3015P to be turned on or off remotely. When the Enable pin (#9) is pulled low, the output is turned off and the unit goes into a very low input power mode.

An open collector switch is recommended to control the voltage between the Enable pin and the P_{gnd} pin of the converter. The Enable pin is pulled up internally, so no external voltage source is required.

If the Enable pin is not used, it can be left floating.

6.2 V_{BOOST} Function

When X3015P is operating with the input voltage lower than 4V, connect the V_{BOOST} pin (#5) to V_{IN}. This improves internal MOSFET operation, making the module more efficient.

Note: V_{BOOST} may only be connected to V_{IN} for input voltages less than 4V.

6.3 Maximum Output Voltage vs. Input Voltage

The maximum steady state output voltage of the converter shall never exceed 70% of the input voltage: $V_{IN\ MIN} \geq V_{OUT}/0.7$.

See graph in Figure 22 for the output voltage ranges at different input voltages.

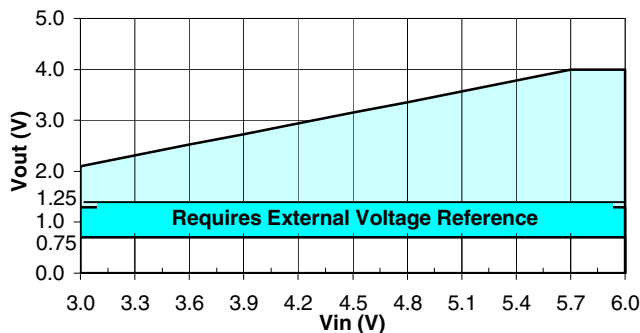

Figure 22. Output Voltage vs. Input Voltage

6.4 Output Voltage Trim

The output voltage is preset (default) to 2.5V.

The trim feature allows the user to adjust the output voltage from this default value.

Increase V_{OUT}: Trim range 2.5V < V_{OUT} ≤ 4.0V

An external resistor (R_{TU}) is placed between the Trim pin (#10) and the -V_S pin (#13, 14, 23) (pad R03 on the evaluation board). Value of the R_{TU} is determined from the equation below:

$$R_{TU} = 1.25 / (V_{OUT} - 2.5) - 0.015, \text{ k}\Omega,$$

where V_{OUT} is the required output voltage.

Decrease V_{OUT}: Trim range 1.25V ≤ V_{OUT} < 2.5V

An external resistor (R_{TD}) is placed between the Trim pin (#10) and the +V_S pin (#11) (pad R07 on the evaluation board). Value of the R_{TD} is determined from the equation below:

$$R_{TD} = 1.25 / (2.5 - V_{OUT}) - 1.015, \text{ k}\Omega$$

Decrease V_{OUT}: Trim range 0.75V ≤ V_{OUT} < 1.25V

An external voltage reference >1.25V is required to trim the X3015P below 1.25V. Two external resistors are required for trimming and should be 0.1% tolerance to improve output voltage accuracy. A 357Ω resistor is placed between the Trim pin and the +V_S pin and a resistor R_{EXT} is placed between the Trim pin and the positive terminal of the external reference voltage (pad R10 on the evaluation board). Value of the R_{EXT} is determined from the equation below:

$$R_{EXT} = (V_{REF} - 1.25) / (6 - 3.8 \cdot V_{OUT}), \text{ k}\Omega,$$

where V_{REF} is the external reference voltage.

Table 3. Sample Trim Resistance Values

V _{OUT} (V)	R _{EXT} (Ω)	R _{TD} (Ω)	R _{TU} (Ω)
1.0	569 (V _{REF} = 2.5V)		
1.3		27	
1.5		237	
1.8		768	
2.5	----- None – factory default -----		
3.3			1540
4.0			820

It is possible to adjust the output voltage of the X3015P with an external voltage signal applied to the Trim pin. Refer to the “X3015P Application Note” for more details.

6.5 Switching Frequency Adjustment

The X3015P operates at a preset switching frequency of 300kHz, but can be programmed up to a maximum frequency of 500kHz by an external resistor (R_F) placed between the Freq pin (#7) and the $-V_S$ pin (pad R01 on eval board). Values of R_F for various switching frequencies are listed on the Table 4.

Table 4. Values of the Frequency Adjustment Resistor R_F

Frequency	R_F (k Ω)
300 kHz	∞ (factory default)
400 kHz	56
500 kHz	24

The benefit of switching the converter at a higher frequency is the reduction of cost, size, and number of output filter components. However, switching losses increase at higher frequency that may lead to efficiency degradation. Use the “X3015P Analysis Tool” available from www.power-one.com to compare designs at different switching frequencies.

The Freq pin can also be used for frequency synchronization and modulation. Refer to the “X3015P Application Note” for more details.

6.6 Undervoltage Lockout

The undervoltage lockout circuit monitors the input voltage applied to it and does not allow the X3015P to turn on until the input voltage reaches 2.85V. At that point, the X3015P initiates a soft start and powers up.

6.7 Remote Voltage Sense

This provides improved load regulation by allowing the unit to compensate for the voltage drop between the converter and the load. Remote sense is achieved by Kelvin connections routed from the $+V_S$ and $-V_S$ pins of the X3015P to the corresponding points at the load. To achieve optimal regulation and reduce noise susceptibility, it is recommended that these connections be routed adjacent to a ground plane.

6.8 Overcurrent Protection

To provide protection from an output overload or short circuit condition, the X3015P is equipped the

current limiting circuitry and can endure the fault condition for an unlimited duration. When the output current increases beyond the current limit setpoint (between 115% to 200% of the full load), the X3015P goes into the hiccup mode of operation.

Once the overload or short circuit is removed, the converter automatically exits the hiccup mode and continues normal operation.

6.9 Current Limit Adjustment

The current limit inception point is determined by the ESR of the output inductor, the PCB trace resistance from the V_{SW} pin (#21) to the output inductor, and the resistance from the output inductor to $+V_S$ pin. The combination of these resistances acts as a sense resistor (R_S) measuring the output current level. Thus, the value of R_S can be determined from the equation below:

$$R_S = ESR_L + R_{TRACE}(V_{SW} \rightarrow L) + R_{TRACE}(L \rightarrow +V_S)$$

Then, the current limit inception point is determined from the equation below:

$$I_{CL} = 0.103/R_S$$

The current limit adjustment allows greater flexibility to set the output current limit inception point using an external resistor.

Decreasing current limit inception point to I_{CLD}

An external resistor (R_{CD}) is placed between the OCP pin (#6) and the V_{SW} pin (pad R08 on eval board). Value of the R_{CD} is determined from the equation below:

$$R_{CD} = A * 22000 / (22000 - A), \Omega,$$

$$\text{where } A = (I_{CLD} * (367440 * R_S)) - 15800$$

Increasing current limit inception point to I_{CLU}

An external resistor (R_{CU}) is placed between the OCP pin and $+V_S$ pin (pad R09 on eval board). Value of the R_{CU} is determined from the equation below:

$$R_{CU} = (15800 * B) / (15800 - B), \Omega,$$

$$\text{where } B = 22000 / ((R_S * 23.256 * I_{CLU}) - 1)$$

Notes:

1. Refer to the “X3015P Application Note” before performing the calculations.
2. As the calculations require high accuracy, it is strongly recommended to use the “X3015P Analysis Tool” to determine values of R_{CU} and R_{CD} .

6.10 Safety Considerations

The X3015P modules **do not provide isolation** from input to output. The input devices powering X3015P must provide relevant isolation requirements according to all IEC60950 based standards. Nevertheless, if the system using the converter needs to receive safety agency approval, certain rules must be followed in the design of the system. In particular, all of the creepage and clearance requirements of the end-use safety requirements must be observed. These documents include UL60950 - CSA60950-00 and EN60950, although

specific applications may have other or additional requirements.

The X3015P modules have no internal fuse. If required, the external fuse needs to be provided to protect the module from catastrophic failure. Refer to the “Input Fuse Selection for DC/DC converters” application note on www.power-one.com for proper selection of the input fuse. Both input traces and the chassis ground trace (if applicable) must be capable of conducting a current of 1.5 times the value of the fuse without opening. The fuse must not be placed in the grounded input line.

In order for the output of the X3015P module to be considered as SELV (Safety Extra Low Voltage), according to all IEC60950 based standards, the input to the module needs to be supplied by an isolated secondary source providing a SELV also.

7. Pinout Diagram

Pin	Function	Name
1	Input Voltage	V_{IN}
2	Input Voltage	V_{IN}
3	Input Voltage	V_{IN}
4	Input Voltage	V_{IN}
5	Boost Voltage	V_{BOOST}
6	Current Trim	OCP
7	Frequency Adjust	Freq
8	Do not connect to any CCT net	N/C
9	User controlled turn on/off	Enable
10	Output Voltage Adjust	Trim
11	Positive voltage sense	$+V_S$
12	Do not connect to any CCT net	N/C
13	Negative Voltage Sense	$-V_S$
14	Negative Voltage Sense	$-V_S$
15	Power Ground	Pgnd
16	Power Ground	Pgnd
17	Power Ground	Pgnd
18	Power Ground	Pgnd
19	Power Ground	Pgnd
20	Power Ground	Pgnd
21	Switch Voltage (Output to inductor or LC filter)	V_{SW}
22	Input Voltage	V_{IN}
23	Negative Voltage Sense	$-V_S$

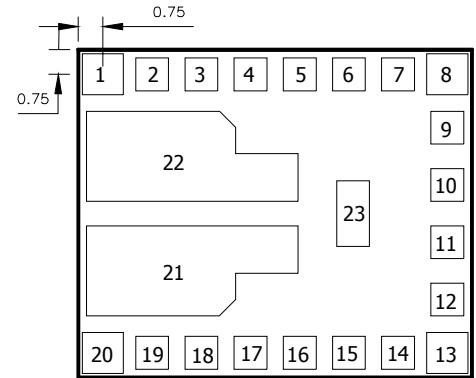

Pinout - Bottom View

8. Pin Descriptions

V_{IN} (Pin 1 – 4, 22): Input Voltage, 3 – 6V. Connect to the input voltage source.

Pgnd (Pin 15 – 20): Ground. Connect to ground/common.

$+V_S$ (Pin 11): Positive Voltage Sense. Connect to the positive point close to the load.

$-V_S$ (Pins 13, 14, 23): Negative Voltage Sense. Connect to the negative/ground point close to the load. This pin is also used as signal ground.

Trim (Pin 10): Output Voltage Trim. If the pin is left floating, the output voltage is set to 2.5 V. To increase the output voltage, connect an external resistor from the Trim pin to $-V_S$. To decrease the output voltage, connect an external resistor from the Trim pin to $+V_S$.

Enable (Pin 9): Enable Pin. TTL compatible ON/OFF control. When the pin is left floating or pulled higher than 1.5V, the output of the converter is enabled (ON). When the pin is connected to Pgnd, or pulled below 0.75V, the output of the converter is disabled (OFF).

Freq (Pin 7): Switching Frequency Adjustment. When the pin is left floating the switching frequency is 300kHz. With 56k Ω resistor connected to the $-V_S$ pin, the operating frequency is increased to 400kHz. With 24k Ω resistor the frequency is set to 500kHz.

OCP (Pin 6): Current Limit Adjustment. This pin allows access to the positive terminal of the current amplifier. Current limit can be increased by connecting a resistor to the $+V_S$ pin and reduced by connecting a resistor to the V_{SW} pin.

V_{BOOST} (Pin 5): Boost Voltage. When operating with input voltages below 4V, it is recommended to connect the pin to V_{IN} to improve efficiency of the converter. Never connect V_{BOOST} pin to V_{IN} when operating with input voltages in excess of 4V.

V_{SW} (Pin 21): Switch Voltage. This is the switch voltage node. Connect to the output inductor with a low impedance trace.

N/C (Pin 8 & 12): No connection. Do not connect these pins to any point in the circuit.

9. Mechanical Drawings

All Dimensions are in mm

Tolerances:
0.5-10 ±0.1
10-100 ±0.2

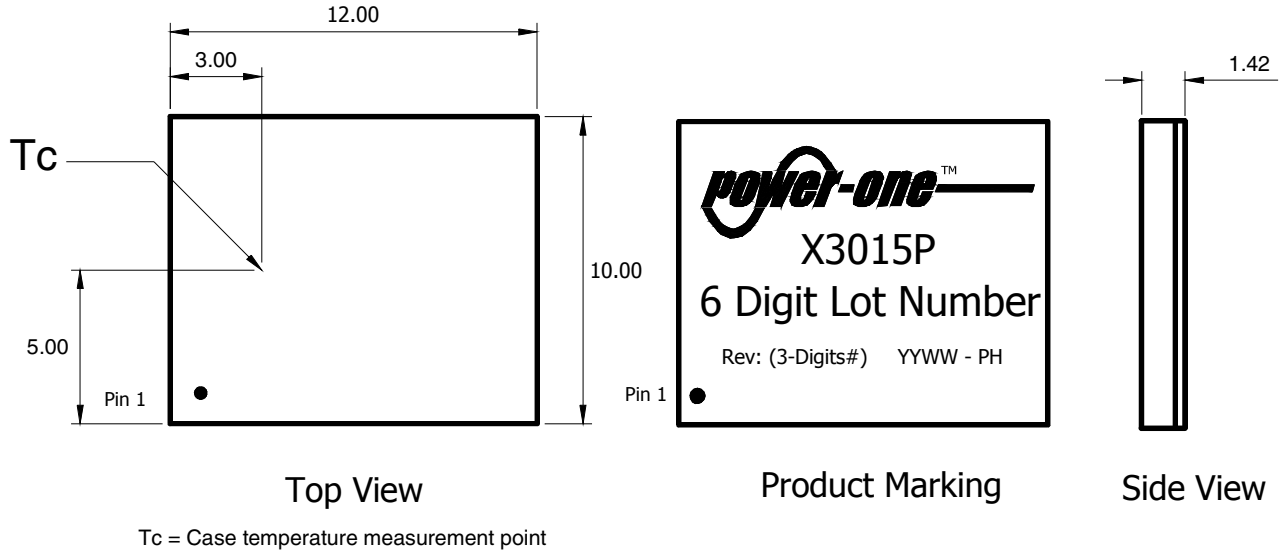

Figure 23. X3015P Mechanical Drawing

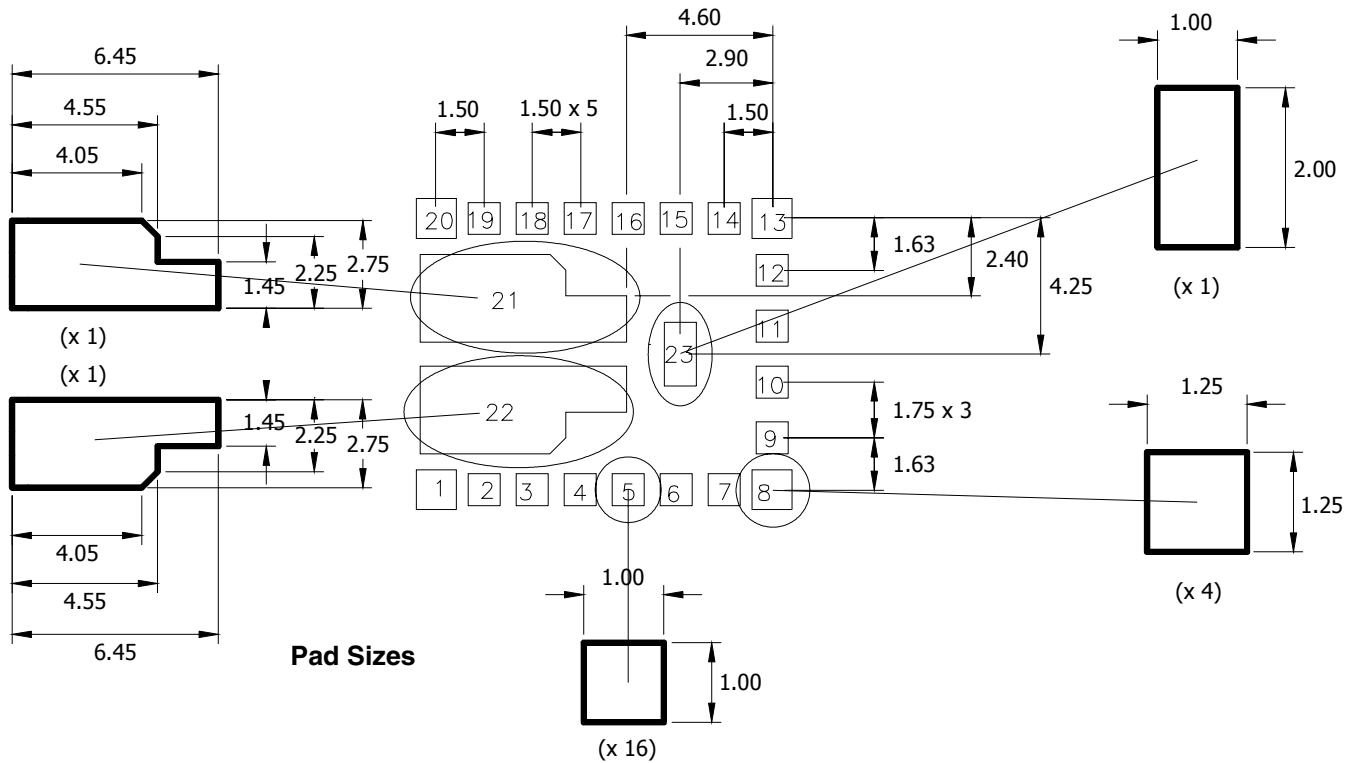

Figure 24. Recommended PCB Layout (Refer to the "X3015P Application Note" for more details)

APPENDIX A: Setup and use of the evaluation board for testing and characterization of the X3015P

A1. Purpose

This procedure explains the requirements for the proper handling, setup, and testing of the X3015P evaluation board.

A2. Overview

Certain conditions have to be met in order to test the functionality of this device. The X3015P data sheet determines both temperature and power limitations involved in the testing and operation of the device. These limitations must not be exceeded. Prolonged operation at elevated temperature or elevated power output can result in the failure of the device.

A3. References

All specifications are referenced against the latest revision of the data sheet.

A4. Procedure

A4.1 Test Equipment

The input source powering the evaluation board should be capable of delivering a minimum of 20A and must have the overvoltage protection.

The loads must be 30A capable and operate at voltages down to 0.7V.

Lead length between the input source and the evaluation board and between the evaluation board and the load should not exceed 3ft (1m).

Additional input capacitance may be required under specific conditions. The amount of capacitance required is a factor of the input impedance, the input voltage, the input voltage regulation, and the output current.

NOTE:

Two 220µF tantalum capacitors C13 and C14 are placed on the evaluation board for bench test purposes only. This ensures that the source impedance is always less than the input impedance of the converter and satisfies the control loop stability criteria. In normal operation the X3015P is powered by a front-end supply located in close proximity, and therefore does not require any additional input capacitance.

A4.2 Connection of Test Equipment

Pgnd is the device ground pin. The input and output ground connections are tied to this pin.

Output voltage regulation measurements are taken from the output voltage sense pins.

To determine unit power dissipation measure averaged output voltage at sense pins (before the inductor).

User adjustable switch SW1 (Factory settings, Pin 3 & 8 ON)

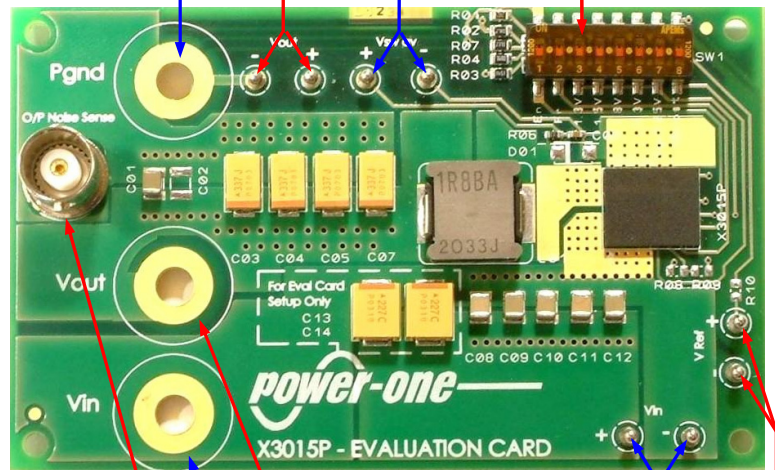

The positive output voltage is connected to the **Vout** pin.

The positive input voltage is connected to the **Vin** pin.

Output ripple is measured using the **O/P Noise Sense 50Ω BNC**

Input voltage measurements are taken from the input voltage sense pins

Voltage reference input (for outputs below 1.25V)

A4.3 Factory Settings and Output Voltage Adjustments

To enable the evaluation board set EN (SW1 Pin1) to OFF; to disable set SW1 Pin1 to ON position. The factory setting is SW1 Pin1 OFF (enable).

Note:

To avoid damage to the device always observe the following:

- $V_{out} < 0.7V_{in}$
- SW1 Pin8 should be ON only, if the input voltage is below 4V. If the input voltage exceeds 4V, the SW1 Pin8 should be OFF

Factory Settings 1.3V

SW1	OFF	ON
Pin 1	●	
Pin 2	●	
Pin 3		●
Pin 4	●	
Pin 5	●	
Pin 6	●	
Pin 7	●	
Pin 8		●

The evaluation board factory setting for output voltage is 1.3V (SW1 Pin3 ON).

When operating below 4V, SW1 Pin8 should be ON to activate V_{BOOST}

The evaluation board factory setting for V_{BOOST} is active (SW1 Pin8 to ON).

Settings for 2.5V

SW1	OFF	ON
Pin 1	●	
Pin 2	●	
Pin 3	●	
Pin 4	●	
Pin 5	●	
Pin 6	●	
Pin 7	●	
Pin 8	Check Vin	

The output of 2.5V (X3015P default) requires SW1 Pins 3 to 7 to OFF.

Setting for 3.3V

SW1	OFF	ON
Pin 1	●	
Pin 2	●	
Pin 3	●	
Pin 4	●	
Pin 5	●	
Pin 6		●
Pin 7	●	
Pin 8	●	

To change the output to a set preprogrammed voltage of 1.3V, 1.5V, 1.8V or 3.3V a single switch must be set ON of SW1 pins 3 to 6 respectively, example shown for 3.3V output. (NOTE: Pin8 must be OFF as V_{BOOST} should not be active for $V_{in} > 4V$)

Settings for >2.5V

SW1	OFF	ON
Pin 1	●	
Pin 2	●	
Pin 3	●	
Pin 4	●	
Pin 5	●	
Pin 6		●
Pin 7	●	
Pin 8	Check Vin	

To change the output voltage to a voltage **greater** than the X3015P default (>2.5V), a resistor needs to be placed on pad R03 (replacing the existing resistor used to generate 3.3V. Refer to the data sheet to calculate value of the resistor).

1.25V < Setting < 2.5V

SW1	OFF	ON
Pin 1	●	
Pin 2	●	
Pin 3	●	
Pin 4		●
Pin 5	●	
Pin 6	●	
Pin 7	●	
Pin 8	Check Vin	

To change the output voltage to a voltage **less** than the default ($1.25 < V_{OUT} < 2.5V$) a resistor needs to be placed across pad R07 (replacing the existing resistor used to generate 1.5V. Refer to the data sheet to calculate value of the resistor).

Settings < 1.25V

SW1	OFF	ON
Pin 1	●	
Pin 2	●	
Pin 3		●
Pin 4	●	
Pin 5	●	
Pin 6	●	
Pin 7		●
Pin 8	Check Vin	

To achieve an output **less than 1.25V**, SW1 Pin3 and pin 7 are set ON. An external voltage >1.25V is applied to the V_{REF} pins of the evaluation board. R02 is replaced with a 357Ω resistor. R10 is required to set the output voltage. Refer to the data sheet to calculate value of the resistor.

A4.4 Frequency and OCP Adjustments

To change switching frequency set SW1 Pin2 to ON, and place a resistor on pad R01. Refer to the data sheet for value of the resistor.

To change the overcurrent protection inception point, a resistor is placed on pad R08 (to increase the overcurrent threshold) or R09 (to decrease increase the overcurrent threshold). Refer to the "X3015P Analysis Tool" to calculate value of the resistors.

Note: R_S is typically 4.5 mΩ for the evaluation board.

A4.5 Turn-on procedure

Before applying power to the evaluation board, set the overvoltage protection of the input source to 7V and ensure that the input voltage sense leads are directly connected to the evaluation board terminals to provide proper regulation and input voltage stability.

Start the input source at 0V and slowly increase to approximately 3V, then turn on load (preferably half load initially).

A4.6 Measurements

Input voltage measurements should be taken at V_{IN} sense pins to improve accuracy. Output voltage should be measured at V_{OUT} sense pins using a standard voltage meter.

Measure noise on BNC with a standard coaxial lead (50Ω, 20MHz bandwidth).

Standard shunts should be used for current measurements.

A5. Evaluation Board Schematic and BOM

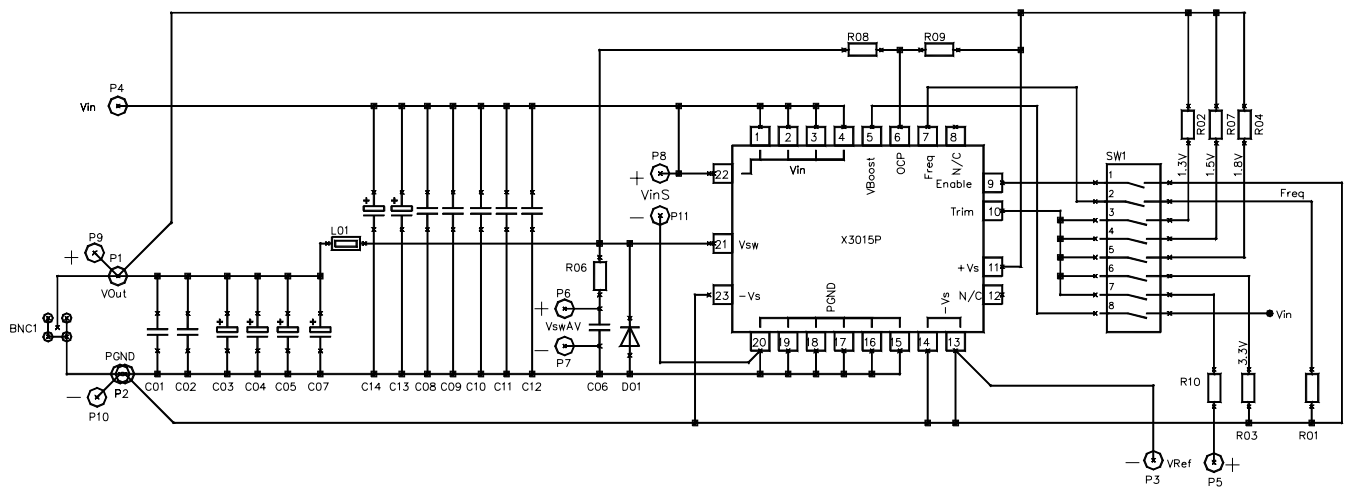

Figure 27. Evaluation Board Schematic

Table 5. X3015P Evaluation Board BOM

Reference Designator	Vendor	Description	Part Number	Qty
SW1		8 way DIL switch		1
D01		Schottky Diode (optional)		0
C06		1nF cap		1
C03, C04, C05, C07	AVX	330μF/6V Case D	TPSD337M006R0045	4
C01, C08, C09, C10, C11, C12	Kyocera	10μF X7R 10V 1210	CM32X7R106M10AB	6
C02		Not placed		0
C13, C14	AVX	220μF/16V Case V	TPS227K016R0100	2
L01	Panasonic	1.5μH, 20A, ESR 3.3mOhm	ETQP6F1R8BFA	1
L01 (alternative AVL part)	(BI)	(1.5μH, 18A, ESR 2.3mOhm)	(HM73-301R5)	(1)
IC01	Power-One	15A POL DC-DC converter	X3015P	1
R01		24kΩ, 1% resistor		1
R02		27Ω, 1% resistor		1
R03		1.54kΩ, 1% resistor		1
R04		768Ω, 1% resistor		1
R06		10kΩ, 1% resistor		1
R07		237Ω, 1% resistor		1
R08... R10		1% resistors (calculated)	(see data sheet)	