

REVISION RECORD				
REV	ECO	DESCRIPTION	DRFT	CHKD
▲		MODIFY DIM	ANKUE	8/13/05

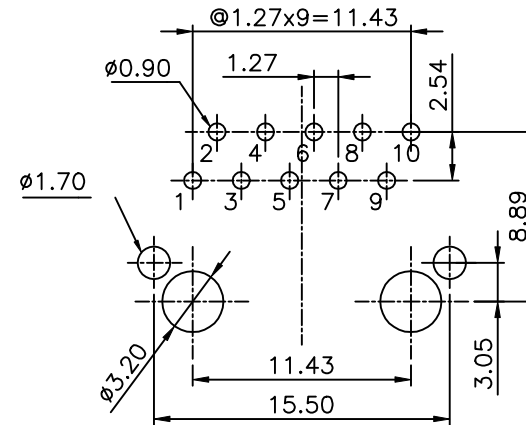
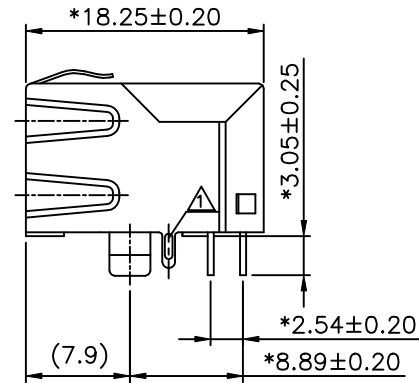
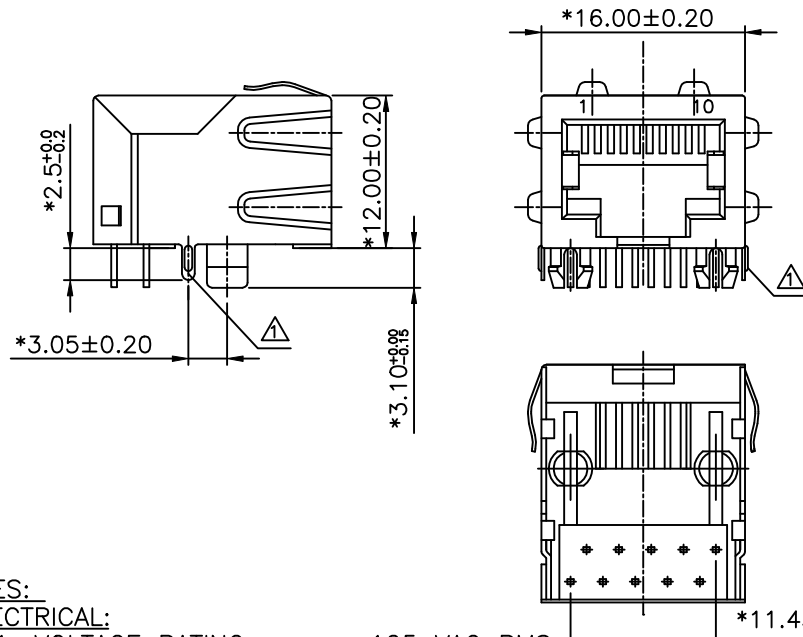

PC Board Layout Component Side Shown

NOTES:

ELECTRICAL:

- VOLTAGE RATING : 125 VAC RMS.
- CURRENT RATING : 1.5 AMP.
- CONTACT RESISTANCE : 45MILLIOHMS MAX.
- INSULATION RESISTANCE: 1000 MEGOHMS MIN @ 500 VDC.
- DIELECTRIC STRENGTH : 1000 VAC RMS 60Hz, 1MIN.

MECHANICAL:

- HOUSING MATERIAL : GLASS FILLED POLYESTER UL94V-0.
- CONTACT MATERIAL : PHOSPHOR BRONZE t=0.35mm.
- PLATING : GOLD PLATING OVER NICKEL.
- OPERATING LIFE : 750 CYCLES MIN.
- PCB RETENTION PRE-SOLDER : 1 LB MIN.
- PCB RETENTION POST-SOLDER: 10 LBS MIN.

ENVIRONMENTAL:

- STORAGE : -40°C TO +85°C.
- OPERATION: 0°C TO 70°C.
- WAVE SOLDER TEMPERATURE: 230°C TO 250°C 3~5 SECOND.

MATES WITH MODULAR PLUG CONFORMING TO FCC PART 68, SUBPART F.

CUL FILE NO. E163191

PART NUMBER: E560X-XS008X-L

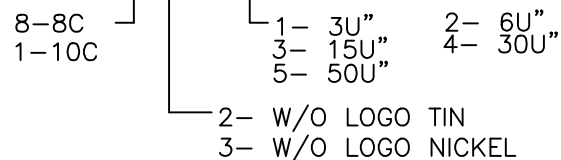

DETACHED LISTS	← MM (INCH) →	DFTO ANKUE	DATE 5/27/2005	FULL RISE ELECTRONIC CO., LTD	
	TOLERANCES EXCEPT AS NOTED	CHKD JAKE	DATE 2005/09/14		
	MM	MFO	DATE	TITLE	
	.0 ±0.20 ±	APPVLLUSHENG	DATE 2005/09/14	11.5 SIDE ENTRY PCB JACK 8P (W/TABS)	
.00 ±0.15 ±	MATERIAL :		DRAWING NO. GE563116-LC		
.000 ±0.075 ±	ANGLES ±		/PART NO. SEE NOTE		
THIRD ANGLE PROJECTION	FINISH :		SIZE A3	REV 1	
	SCALE :		DO NOT SCALE DRAWING		
			SHEET X	OF Y	