

■Features

- Highest Luminous Flux
- Super Energy Efficiency
- Long Lifetime Operation
- Superior ESD protection
- Superior UV Resistance

■Applications

- Read lights (car, bus, aircraft)
- Portable (flashlight, bicycle)
- Bollards / Security / Garden
- Traffic signaling / Beacons
- In door / Out door Commercial lights
- Automotive Ext

■Outline Dimension

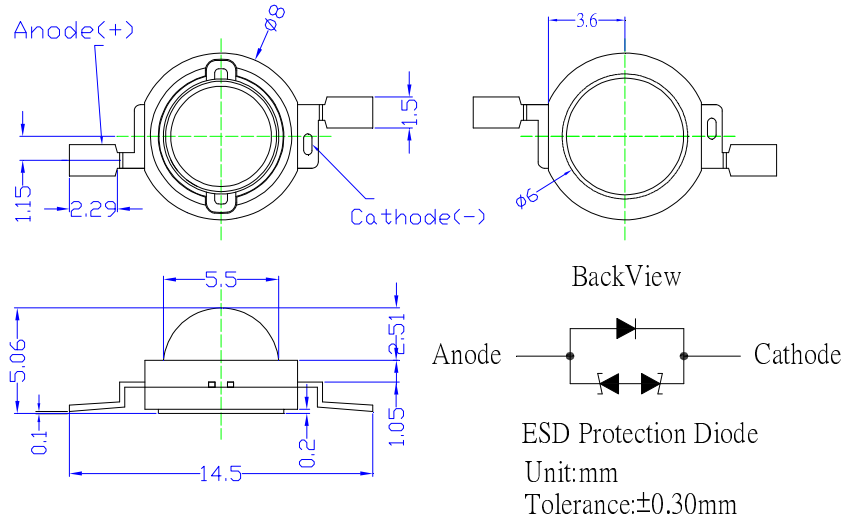

■Absolute Maximum Rating

($T_a=25^{\circ}\text{C}$)

Item	Symbol	Value	Unit
DC Forward Current	I_F	800	mA
Pulse Forward Current*	I_{FP}	1000	mA
Reverse Voltage	V_R	5	V
Power Dissipation	P_D	3200	mW
Operating Temperature	T_{opr}	-30 ~ +85	$^{\circ}\text{C}$
Storage Temperature	T_{stg}	-40 ~ +100	$^{\circ}\text{C}$
Lead Soldering Temperature	T_{sol}	260 $^{\circ}\text{C}$ /5sec	-

*Pulse width Max.10ms Duty ratio max 1/10

■Directivity

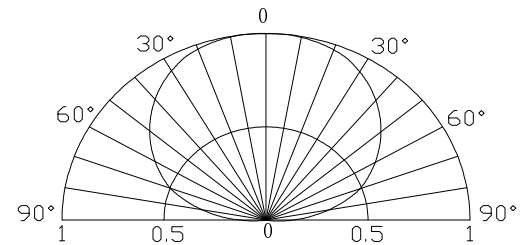

■Electrical -Optical Characteristics

($T_a=25^{\circ}\text{C}$)

Item	Symbol	Condition	Min.	Typ.	Max.	Unit
DC Forward Voltage	V_F	$I_F=350\text{mA}$	3.0	3.3	4.0	V
		$I_F=700\text{mA}$	3.5	3.8	4.5	V
DC Reverse Current	I_R	$V_R=5\text{V}$	-	-	10	μA
Domi. Wavelength	λ_D	$I_F=700\text{mA}$	455	460	465	nm
Luminous Flux	Φ_v	$I_F=700\text{mA}$	25	35	-	lm
50% Power Angle	$2\theta_{1/2}$	$I_F=700\text{mA}$	-	140	-	deg

■Forward Operating Current (DC)

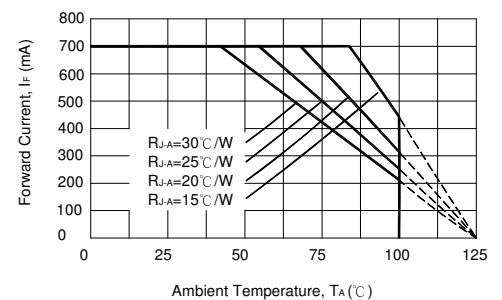

Note: Don't drive at rated current more than 5s without heat sink for Xeon 3 emitter series.

■ **Soldering Heat Reliability (DIP):**

Reflow soldering Profile

- Reflow soldering should not be done more than two times.
- When soldering, do not put stress on the LEDs during heating.
- After soldering, do not warp the circuit board.
- Repairing should not be done after the LEDs have been soldered. When repairing is unavoidable, a double-head soldering iron should be used. It should be confirmed beforehand whether the **characteristics of the LEDs will or will not be damaged by repairing.**

Solder
Average ramp-up rate = 3°C/sec. max.
Preheat temperature: 150°~180°C
Preheat time = 120 sec. max.
Ramp-down rate = 6°C/sec. max.
Peak temperature = 220°C max.
Time within 3°C of actual peak temperature = 25 sec. max.
Duration above 200°C is 40 sec. max.

