



SD106WS

schottky diode

SCHOTTKY DIODES

■ FEATURES

- * Low turn-on Voltage Vd
- * Built-in PN Junction Guard Ring

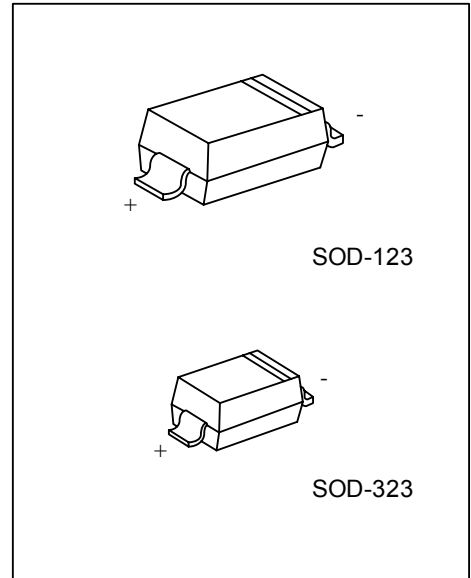

*Pb-free plating product number: SD106WSL

■ ORDERING INFORMATION

Order Number		Package	Packing
Normal	Lead Free Plating		
SD106WS-CA2-R	SD106WSL-CA2-R	SOD-123	Tape Reel
SD106WS-CB2-R	SD106WSL-CB2-R	SOD-323	Tape Reel

<p>SD106WSL-CA2-R</p> <p>(1)Packing Type (2)Package Type (3)Lead Plating</p>	<p>(1) R: Tape Reel (2) CA2: SOD-123, CB2: SOD-323 (3) L: Lead Free Plating Blank: Pb/Sn</p>
--	--

■ MARKING

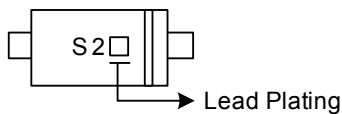

■ ABSOLUTE MAXIMUM RATINGS (Single Diode @ $T_A=25$)

PARAMETER	SYMBOL	RATINGS	UNIT
Maximum non-repetitive Peak Reverse Voltage	V_{RM}	30	V
Peak Forward Current	I_{FM}	200	mA
Non-repetitive Peak Forward Surge Current @ $t_p=10ms$	I_{FSM}	1	A
Power Dissipation	P_D	250	mW
Junction Temperature	T_J	150	
Storage Temperature	T_{STG}	-65~+150	

Note: Absolute maximum ratings are those values beyond which the device could be permanently damaged.

Absolute maximum ratings are stress ratings only and functional device operation is not implied.

■ THERMAL DATA

PARAMETER	SYMBOL	RATINGS	UNIT
Thermal Resistance Junction to Ambient	θ_{JA}	500	/W

■ ELECTRICAL CHARACTERISTICS ($T_A=25$)

PARAMETER	SYMBOL	CONDITIONS	MIN	TYP	MAX	UNIT
Forward Voltage	V_F	$I_F=2mA$		260		mV
		$I_F=15mA$		320		mV
		$I_F=100mA$		420		mV
		$I_F=200mA$		490	550	mV
Reverse Breakdown Voltage	BV_R	$I_R=100\mu A$	30			V
Peak Reverse Leakage Current	I_R	$V_R=30V$			5	μA
Typical Junction Capacitance	C_T	$V_R=10V, f=1MHz$		50	15	pF

■ TYPICAL CHARACTERISTICS

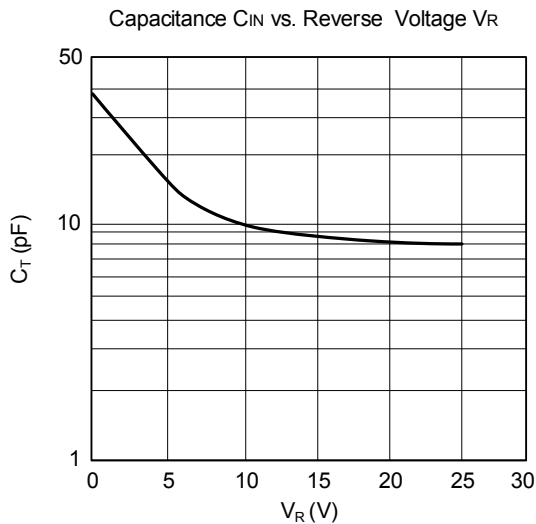
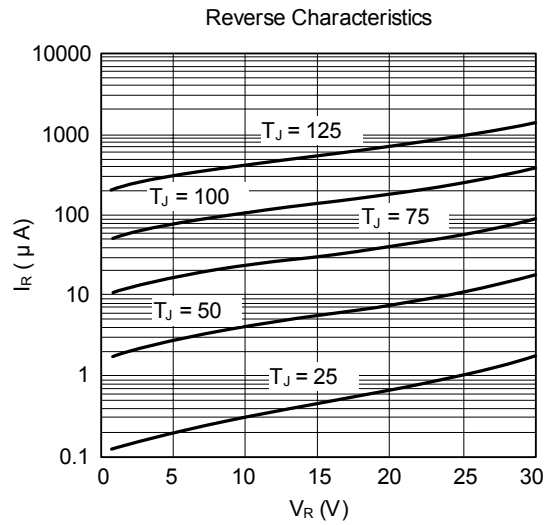
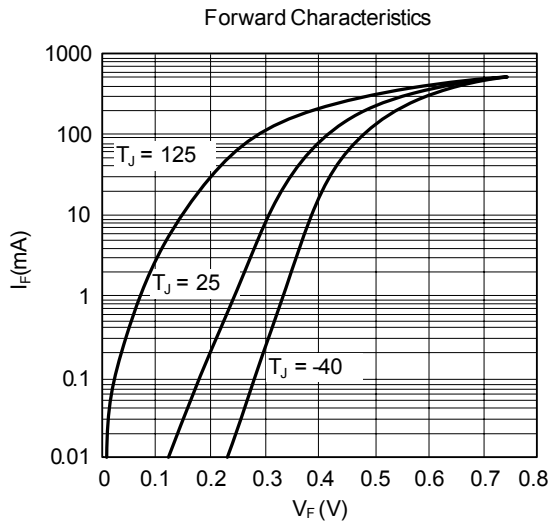

UTC assumes no responsibility for equipment failures that result from using products at values that exceed, even momentarily, rated values (such as maximum ratings, operating condition ranges, or other parameters) listed in products specifications of any and all UTC products described or contained herein. UTC products are not designed for use in life support appliances, devices or systems where malfunction of these products can be reasonably expected to result in personal injury. Reproduction in whole or in part is prohibited without the prior written consent of the copyright owner. The information presented in this document does not form part of any quotation or contract, is believed to be accurate and reliable and may be changed without notice.