

ZXCT1010

ENHANCED HIGH-SIDE CURRENT MONITOR

DESCRIPTION

The ZXCT1010 is a high side current sense monitor. Using this device eliminates the need to disrupt the ground plane when sensing a load current.

It is an enhanced version of the ZXCT1009 offering reduced typical output offset and improved accuracy at low sense voltage.

The wide input voltage range of 20V down to as low as 2.5V make it suitable for a range of applications. A minimum operating current of just 4 μ A, combined with its SOT23-5 package make suitable for portable battery equipment.

FEATURES

- Low cost, accurate high-side current sensing.
- Output voltage scaling.
- Up to 2.5V sense voltage.
- 2.5V – 20V supply range.
- 300nA typical offset current.
- 3.5 μ A quiescent current.
- 1% typical accuracy.
- SOT23 -5 package.

APPLICATIONS

- Battery Chargers
- Smart Battery Packs
- DC Motor control
- Over current monitor
- Power Management
- Level translating
- Programmable current source

APPLICATION CIRCUIT

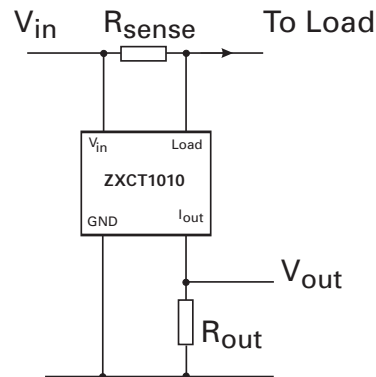

ORDERING INFORMATION

PART NUMBER	PACKAGE	PARTMARKING
ZXCT1010E5	SOT23-5	101

ZXCT1010

ABSOLUTE MAXIMUM RATINGS

Voltage on any pin	-0.6V to 20V (relative to GND)
Continuous output current	25mA
Continuous sense voltage	$V_{in} + 0.5V > V_{sense} > V_{in} - 5V$
Operating Temperature	-40 to 85°C
Storage Temperature	-55 to 125°C
Package Power Dissipation	($T_A = 25^\circ\text{C}$)
SOT23-5	500mW

ELECTRICAL CHARACTERISTICS

Test Conditions $T_A = 25^\circ\text{C}$, $V_{in} = 5V$, $R_{out} = 100\Omega$.

SYMBOL	PARAMETER	CONDITIONS	LIMITS			UNIT
			Min	Typ	Max	
V_{in}	V_{CC} Range		2.5		20	V
I_{out}^1	Output current	$V_{sense} = 0V$	0	0.3	10	μA
		$V_{sense} = 10\text{mV}$	85	100	115	μA
		$V_{sense} = 100\text{mV}$	0.975	1.00	1.025	mA
		$V_{sense} = 200\text{mV}$	1.95	2.00	2.05	mA
		$V_{sense} = 1V$	9.7	10.0	10.3	mA
I_q	Ground pin current	$V_{sense} = 0V$		3.5	8	μA
V_{sense}^2	Sense Voltage		0		2500	mV
I_{sense}	Load pin input current				100	nA
Acc	Accuracy	$R_{sense} = 0.1\Omega$ $V_{sense} = 200\text{mV}$	-2.5		2.5	%
Gm	Transconductance, I_{out} / V_{sense}			10000		$\mu\text{A}/\text{V}$
BW	Bandwidth	RF $P_{in} = -20\text{dBm}^3$		300		kHz
		$V_{sense} = 10\text{mV dc}$ $V_{sense} = 100\text{mV dc}$		2		MHz

¹ Includes input offset voltage contribution

² $V_{sense} = V_{in} - V_{load}$

³ $-20\text{dBm} = 63\text{mVp-p}$ into 50Ω

TYPICAL CHARACTERISTICS

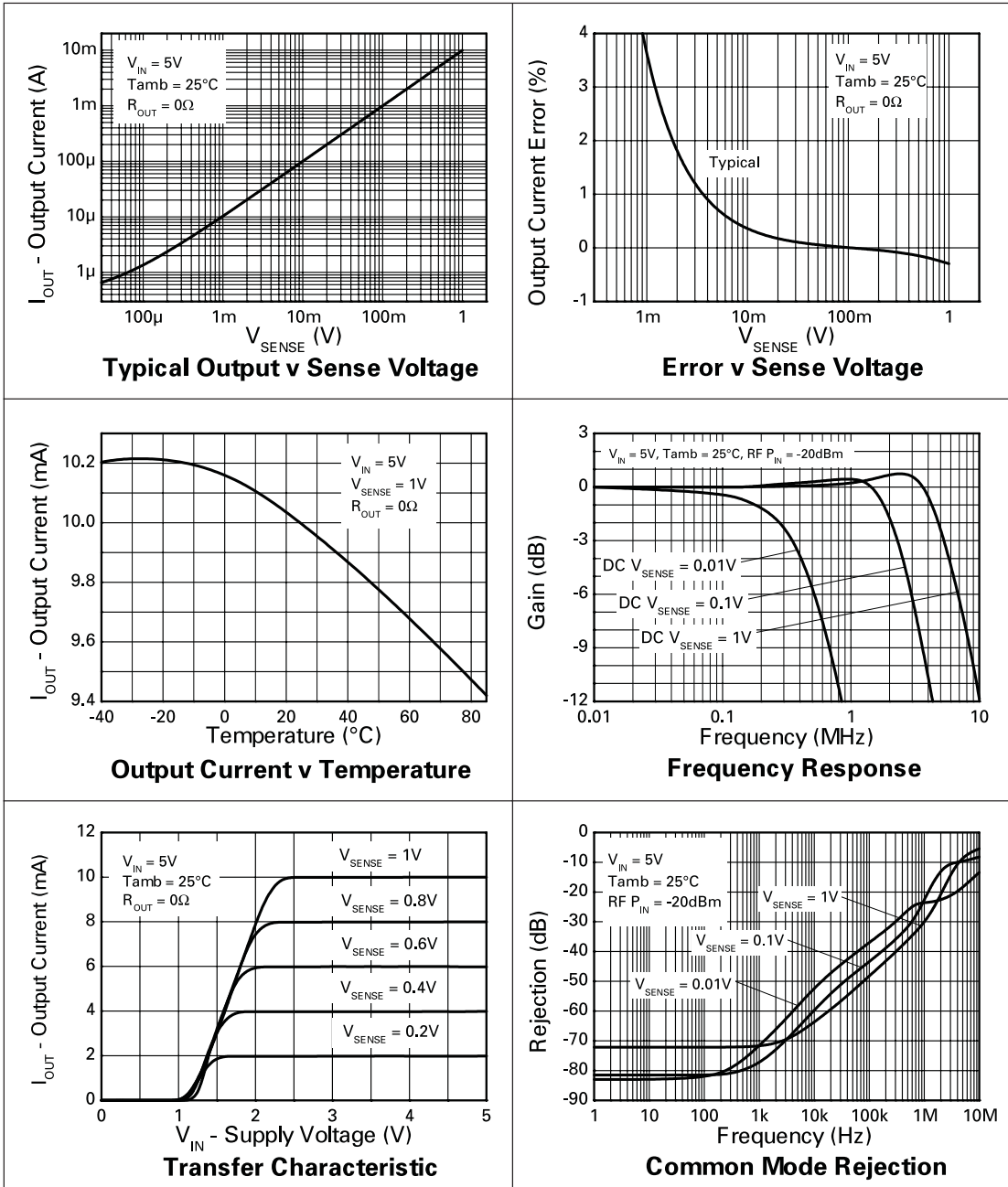

ZXCT1010

PIN DESCRIPTION

Pin Name	Pin Function
V_{in}	Supply Voltage
Load	Connection to load/battery
I_{out}	Output current, proportional to $V_{in} - V_{load}$
GND	Ground

CONNECTION DIAGRAM

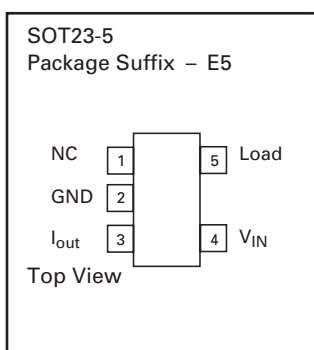

SCHEMATIC DIAGRAM

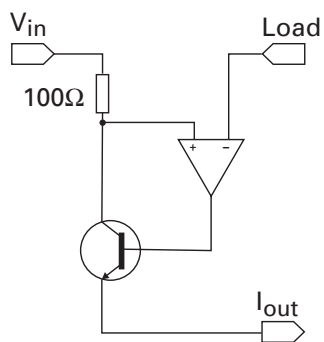

ZXCT1010

POWER DISSIPATION

The maximum allowable power dissipation of the device for normal operation (P_{max}), is a function of the package junction to ambient thermal resistance (θ_{ja}), maximum junction temperature (T_{jmax}), and ambient temperature (T_{amb}), according to the expression:

$$P_{max} = (T_{jmax} - T_{amb}) / \theta_{ja}$$

The device power dissipation, P_D is given by the expression:

$$P_D = I_{out} \cdot (V_{in} - V_{out}) \text{ Watts}$$

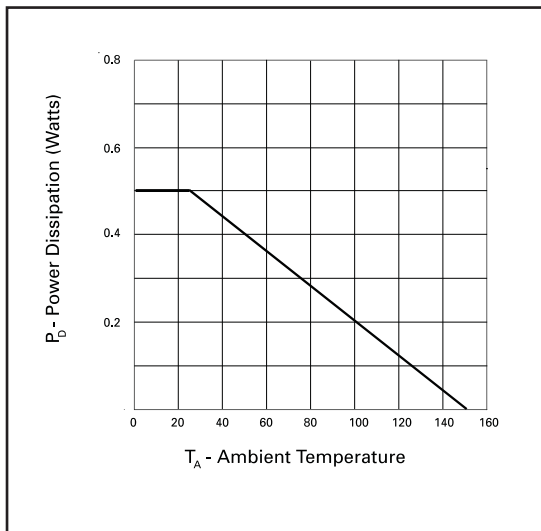

APPLICATIONS INFORMATION

The following lines describe how to scale a load current to an output voltage.

$$V_{sense} = V_{in} - V_{load}$$

$$V_{out} = 0.01 \times V_{sense} \times R_{out}^1$$

E.g.

A 1A current is to be represented by a 100mV output voltage:

1) Choose the value of R_{sense} to give $50mV > V_{sense} > 500mV$ at full load.

For example $V_{sense} = 100mV$ at 1.0A. $R_{sense} = 0.1/1.0 \Rightarrow 0.1 \text{ ohms}$.

2) Choose R_{out} to give $V_{out} = 100mV$, when $V_{sense} = 100mV$.

Rearranging ¹ for R_{out} gives:

$$R_{out} = V_{out} / (V_{sense} \times 0.01)$$

$$R_{out} = 0.1 / (0.1 \times 0.01) = 100 \Omega$$

TYPICAL CIRCUIT APPLICATION

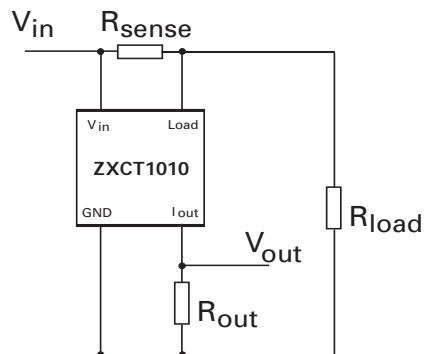

Where R_{load} represents any load including DC motors, a charging battery or further circuitry that requires monitoring, R_{sense} can be selected on specific requirements of accuracy, size and power rating.

ZXCT1010

APPLICATIONS INFORMATION (Continued)

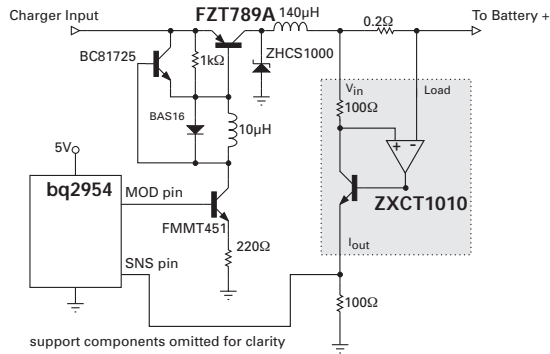

Li-Ion Charger Circuit

The above figure shows the ZXCT1010 supporting the Benchmarq bq2954 Charge Management IC. Most of the support components for the bq2954 are omitted for clarity. This design also uses the Zetex FZT789A high current Super-β PNP as the switching transistor in the DC-DC step down converter and the FMMT451 as the drive NPN for the FZT789A. The circuit can be configured to charge up to four Li-Ion cells at a charge current of 1.25A. Charge can be terminated on maximum voltage, selectable minimum current, or maximum time out. Switching frequency of the PWM loop is approximately 120kHz.

Bi-Directional Current Sensing

The ZXCT1010 can be used to measure current bi-directionally, if two devices are connected as shown below.

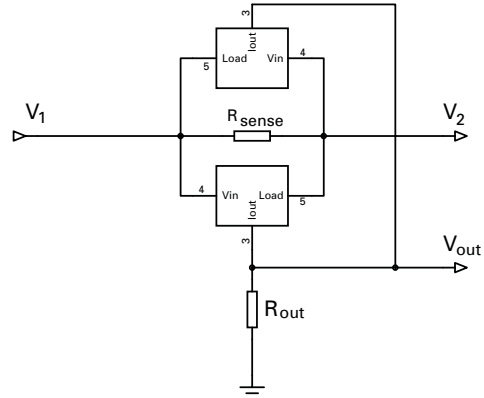

If the voltage V_1 is positive with respect to the voltage V_2 the lower device will be active, delivering a proportional output current to R_{out} . Due to the polarity of the voltage across R_{sense} , the upper device will be inactive and will not contribute to the current delivered to R_{out} . When V_2 is more positive than V_1 , current will be flowing in the opposite direction, causing the upper device to be active instead.

Non-linearity will be apparent at small values of V_{sense} due to offset current contribution. Devices can use separate output resistors if the current direction is to be monitored independently.

Bi-directional Transfer Function

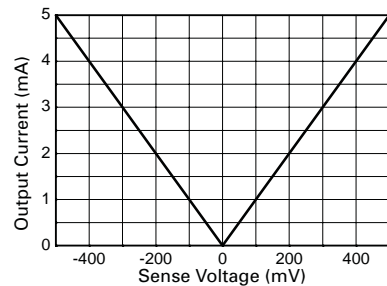

Output Current v Sense Voltage

ZXCT1010

APPLICATIONS INFORMATION (Continued)

PCB trace shunt resistor for low cost solution.

The figure below shows output characteristics of the device when using a PCB resistive trace for a low cost solution in replacement for a conventional shunt resistor. The graph shows the linear rise in voltage across the resistor due to the PTC of the material and demonstrates how this rise in resistance value over temperature compensates for the NTC of the device.

The figure opposite shows a PCB layout suggestion. The resistor section is 25mm x 0.25mm giving approximately 150mΩ using 1oz copper. The data for the normalised graph was obtained using a 1A load current and a 100Ω output resistor. An electronic version of the PCB layout is available at www.zetex.com/isense

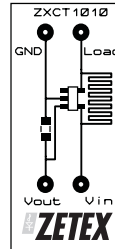

Actual Size

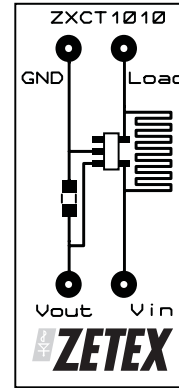

Layout shows area of shunt resistor compared to SOT23-5 package. Not actual size

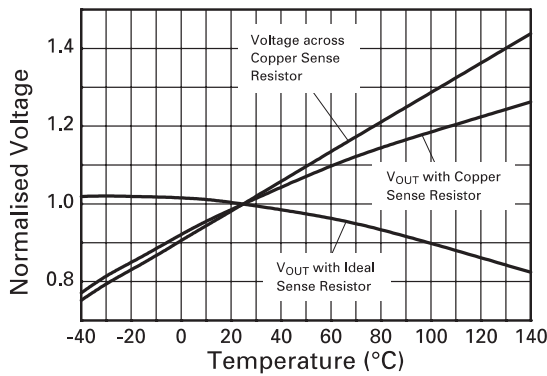

Effect of Sense Resistor Material on Temperature Performance

ZXCT1010

PACKAGE DIMENSIONS SOT23-5

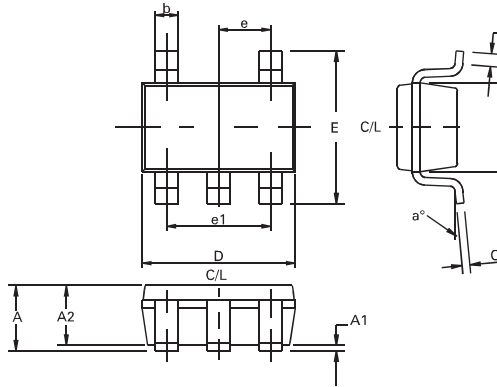

DIM	Millimetres		Inches	
	MIN	MAX	MIN	MAX
A	0.90	1.45	0.035	0.057
A1	0.00	0.15	0.00	0.006
A2	0.90	1.3	0.035	0.051
b	0.35	0.50	0.014	0.020
C	0.09	0.20	0.0035	0.008
D	2.80	3.00	0.110	0.118
E	2.60	3.00	0.102	0.118
E1	1.50	1.75	0.059	0.069
e	0.95 REF		0.037 REF	
e1	1.90 REF		0.075 REF	
L	0.10	0.60	0.004	0.024
a°	0	10	0	10

© Zetex plc 2003

Europe

Zetex plc
Fields New Road
Chadderton
Oldham, OL9 8NP
United Kingdom
Telephone (44) 161 622 4444
Fax: (44) 161 622 4446
hq@zetex.com

Zetex GmbH
Streitfeldstraße 19
D-81673 München
Germany
Telephone: (49) 89 45 49 49 0
Fax: (49) 89 45 49 49 49
europe.sales@zetex.com

Americas

Zetex Inc
700 Veterans Memorial Hwy
Hauppauge, NY 11788
USA
Telephone: (1) 631 360 2222
Fax: (1) 631 360 8222
usa.sales@zetex.com

Asia Pacific

Zetex (Asia) Ltd
3701-04 Metroplaza Tower 1
Hing Fong Road
Kwai Fong
Hong Kong
Telephone: (852) 26100 611
Fax: (852) 24250 494
asia.sales@zetex.com

These offices are supported by agents and distributors in major countries world-wide.

This publication is issued to provide outline information only which (unless agreed by the Company in writing) may not be used, applied or reproduced for any purpose or form part of any order or contract or be regarded as a representation relating to the products or services concerned. The Company reserves the right to alter without notice the specification, design, price or conditions of supply of any product or service.

For the latest product information, log on to www.zetex.com



ISSUE 6 - AUGUST 2003