

Actual Size



Product Description

The crystals are miniature AT or BT cut strip resonators housed in low profile packages for surface mounting. The parts present a proven metal package technology with a precision molded base and universal contact configuration.

Product Features

- 49SNC is interchangeable with popular molded crystal configurations.
- Lead (Pb)-free RoHS Compliant Version Available

Typical Applications

- Set-Top Box
- Clock/VCXO Multiplier
- Fibre Channel
- Ethernet
- Modems
- ADSL
- ISDN
- Microcontrollers
- Remote control devices
- Network processors
- Audio/Video

Frequency Range:

- 3.2 to 29.999 MHz, AT Fundamental
- 26.8 to 50.000 MHz, BT Fundamental
- 30.0 to 80.000 MHz, AT 3rd OT

Temperature Range:

- Operating: -20 to +70°C Standard (see options below)
- Storage: -55 to +125°C

Temperature Stability Tolerance:

- ±30ppm, -20 to +70°C
- ±50ppm, -40 to +85°C, or
- ±100ppm, -40 to +85°C
- 0 to -100ppm for BT
- Others available

Characteristics at 25°C ±2°C:

- Frequency Calibration Tolerance: ±30ppm, ±50ppm (others avail)
- Load Capacitance: 16 to 32pF or Series Resonance
- Effective Series Resistance: 30 to 200-ohm (frequency dependent)
- Drive Level: 100µW correlation, 500µW Max operating
- Shunt Capacitance: 7pF Max.

Mechanical:

- Shock: MIL-STD-883, Method 2002, Condition B
- Solderability: MIL-STD-883, Method 2003
- Solderability: JESD22-B102-D Method 2 (Preconditioning E)
- Terminal Strength: MIL-STD-202, Method 211, Conditions A and C
- Vibration: MIL-STD-883, Method 2007, Condition A
- Solvent Resistance: MIL-STD-202, Method 215
- Resistance to Soldering Heat: MIL-STD-202, Method 210, Condition I or J
- Resistance to Soldering Heat: J-STD-020C Table 5-2 Pb-free devices (3 cycles max)

Environmental:

- Gross Test Leak: MIL-STD-883, Method 1014, Condition C
- Fine Test Leak: MIL-STD-883, Method 1014, Condition A
- Thermal Shock: MIL-STD-883, Method 1011, Condition A
- Moisture Resistance: MIL-STD-883, Method 1004

Reflow Temperature:

- Standard: 240°C Max
- Lead-free: 260°C Max, 10 sec max

Packaging Information: HC-49

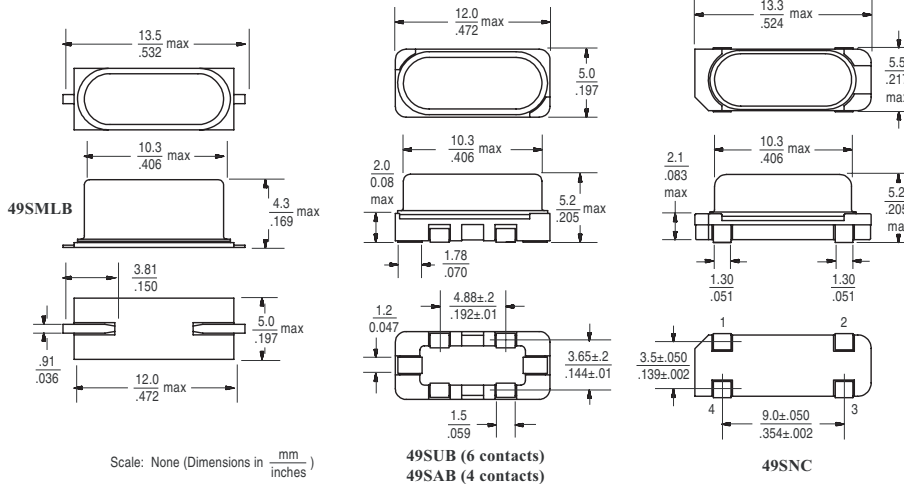

Package Marking Information

Line 1: S = SaRonix
xxx = Calib/Stability/Temp Code
YYWWX = Date Code
Line 2: Frequency (up to 7 digits, including decimal point)
BT-cut = B or
AT-cut Parallel = -(dash) or
AT-cut Series = leave Blank
xx = Load Capacitance (leave Blank if Series)

SxxxYYWWX
24.5760-xx

Land Pattern

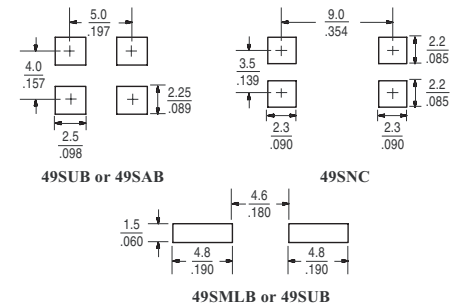

Ordering Information

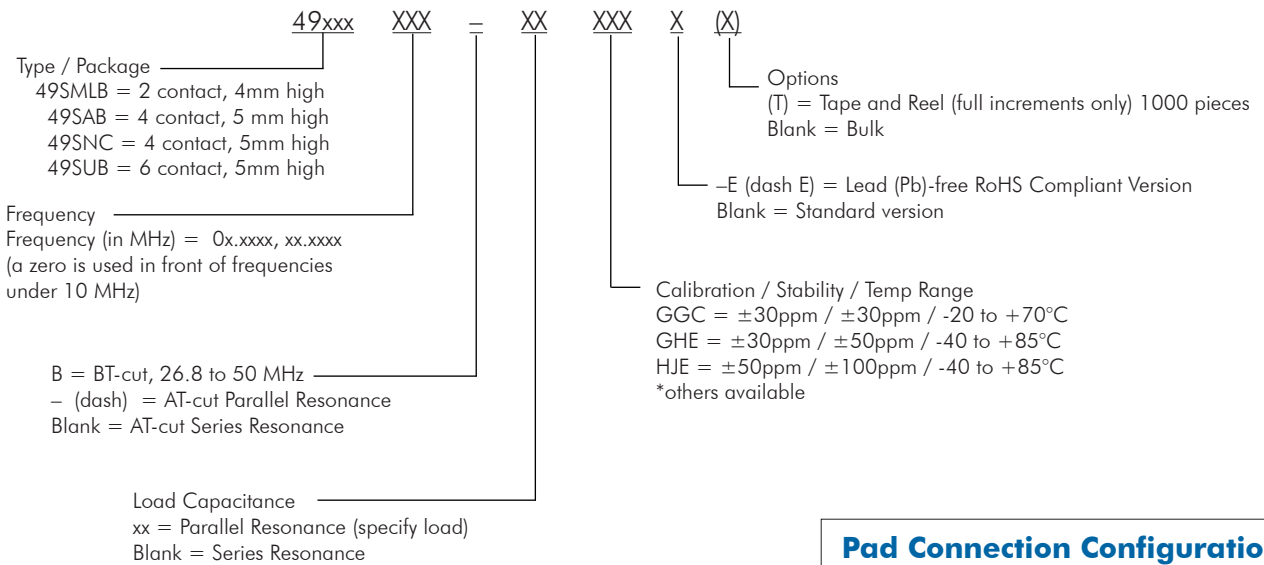

Part Number Examples: Freq 5.1234MHz, ±30ppm calib, ±30ppm stability, -20 to +70°C, 16pF
= 49SMLB05.1234-16GGC
= 49SMLB05.1234-16GGC-E (for lead-free)

Pad Connection Configurations

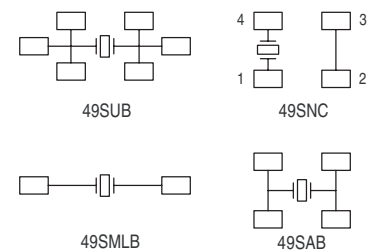

THIS PAGE NOT RECOMMENDED FOR NEW DESIGNS, SEE PAGES 1-2

Packaging Information: HC-49

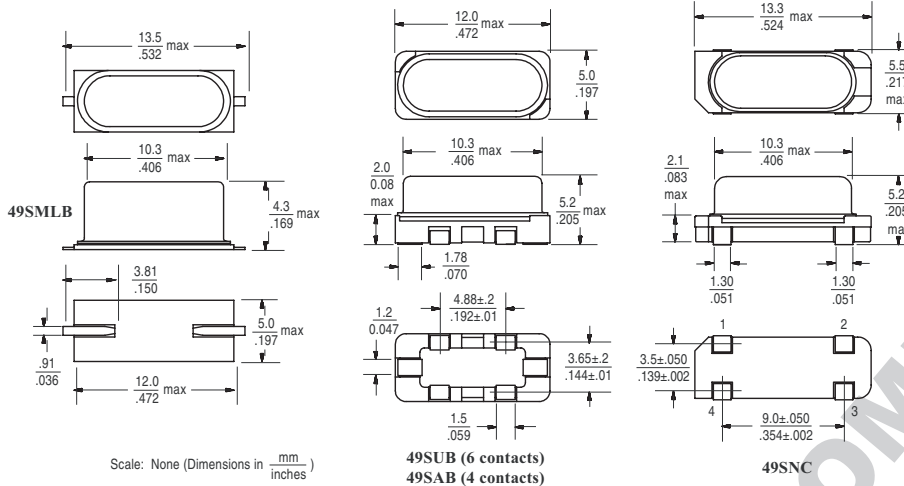

Package Marking Information

Products with custom frequency, calibration, stability, temp:

Line 1: S = SaRonix
-(dash) = separator
xxx = Calib/Stability/Temp Code
Line 2: Frequency (up to 7 digits, including decimal point)
BT-cut = B or
AT-cut Parallel = -(dash) or
AT-cut Series = leave Blank
xx = Load Capacitance (leave Blank if Series)

S-xxxYYWW
24.5760-xx

Products with custom frequency and standard specifications:

Line 1: S = SaRonix
YYWW = Date Code
Line 2: Frequency (up to 7 digits, including decimal point)
BT-cut = B or
AT-cut Parallel = -(dash) or
AT-cut Series = leave Blank
xx = Load Capacitance (leave Blank if Series)

SYWW
24.5760-xx

Ordering Information

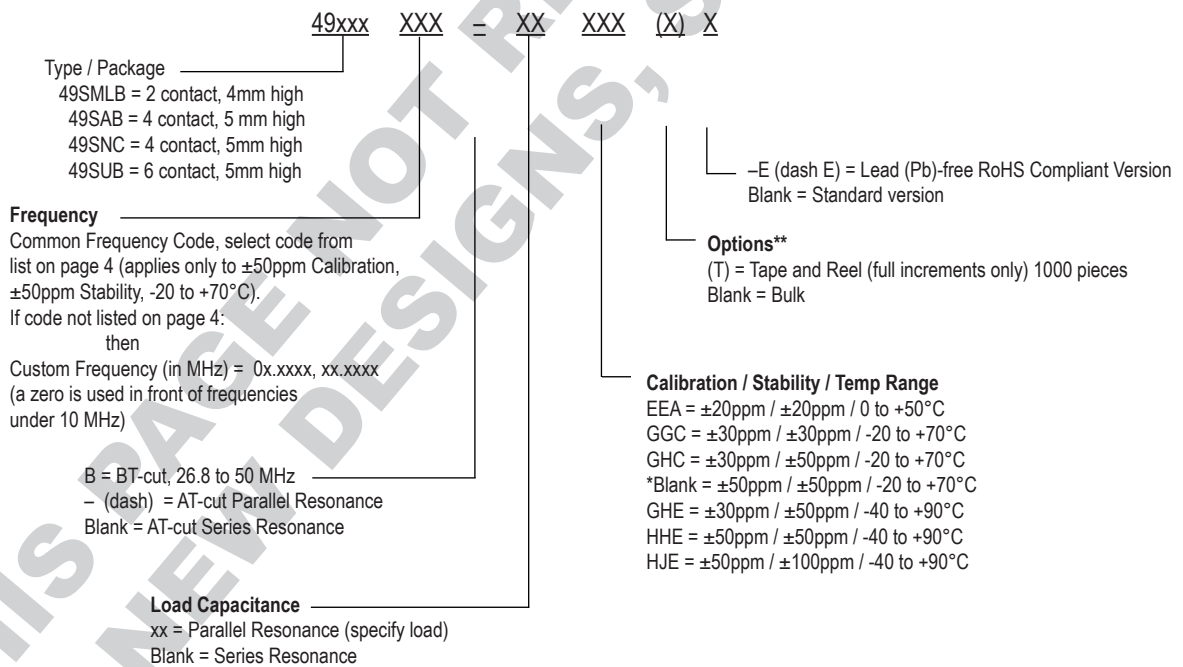

*no code used, as these specs designate standard configuration for this series

Part Number Examples:

Common Freq 20MHz, ± 50 ppm calib, ± 50 ppm stability, -20 to +70°C, 12pF = 49SMLB200-12-E (lead free)
Common Freq 20MHz, ± 50 ppm calib, ± 50 ppm stability, -20 to +70°C, Series = 49SMLB200
Custom Freq 5.1234MHz, ± 30 ppm calib, ± 30 ppm stability, -20 to +70°C, 16pF = 49SMLB05.1234-16GGC

THIS PAGE NOT RECOMMENDED FOR NEW DESIGNS, SEE PAGES 1-2

Legacy Part Number Format

Common frequency codes:

to be used only with ± 50 ppm calibration, ± 50 ppm stability over -20 to +70°C

Solder Reflow Guide

Freq. MHz	Freq. Code	Maximum ESR (Fundamental)	Maximum ESR (3rd OT)
3.579545	035	200	
3.686400	037	160	
4.000000	040	150	
4.915200	049	150	
5.068800	051	120	
6.000000	060	100	
7.372800	073	80	
8.000000	080	80	
10.000000	100	60	
11.059200	111	60	
12.000000	120	60	
12.288000	122	60	
14.318180	143	30	
15.000000	150	30	
16.000000	160	30	
18.000000	180	30	
18.432000	184	30	
19.660800	196	30	
20.000000	200	30	
24.000000	240	30	
24.576000	245	30	
25.000000	250	30	
26.800000	268	30	
28.000000	280	30	
29.491200	294	30	
30.000000	300	30	80
32.000000	320	30	80
32.256000	322	30	80
33.000000	330	30	
33.333000	333	30	
33.868000	338	30	
35.251200	352	30	80
36.000000	360	30	80
40.000000	400	30	80
40.320000	403	30	80
40.960000	409	30	80
42.000000	420	30	80
42.500000	425	30	80
45.000000	450	30	80
46.000000	460	30	80
48.000000	480	30	80
50.000000	500	30	80
52.416000	524	30	80
56.448000	564	30	80
60.000000	600	30	80
66.666667	666	30	80

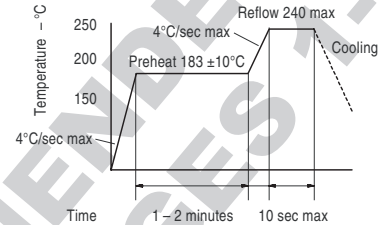

THIS PAGE NOT RECOMMENDED FOR NEW DESIGNS, SEE PAGES 1-2