

FEATURES

- Available in 80/100/120 ns (Max.)
- Automatic power-down when chip disabled
- Lower power consumption:
 - MS621000
 - 5.5mW (Max.) Power Down
 - MS621000L
 - 1.1mW (Max.) Power Down
- TTL compatible interface levels
- Single 5V power supply
- Fully static operation
- Three state outputs
- Two chip enable (\bar{E}_1 and E_2) for simple memory expansion
- Data retention as low as 2V

DESCRIPTION

The MOSEL MS621000 is a high performance, low power CMOS static RAM organized as 131,072 words by 8 bits. The device supports easy memory expansion with both an active LOW chip enable (\bar{E}_1) and an active High chip enable (E_2), as well as an active LOW output enable (\bar{G}) and three state outputs. An automatic power-down feature is included which reduces the chip power by 80% in TTL standby mode, and by over 95% in full power-down mode.

The device is manufactured in MOSEL's high performance CMOS process and operates from a single 5V power supply. All inputs and outputs are TTL compatible. Data is retained to as low as $V_{CC} = 2V$.

The MOSEL MS621000 is packaged in the JEDEC standard 32 pin 600 mil wide DIP and 525 mil wide SOP.

PIN CONFIGURATIONS

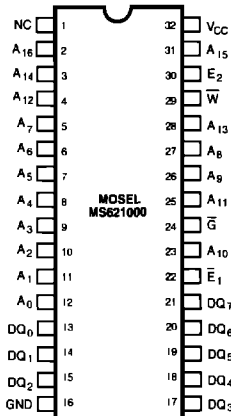

FUNCTIONAL BLOCK DIAGRAM

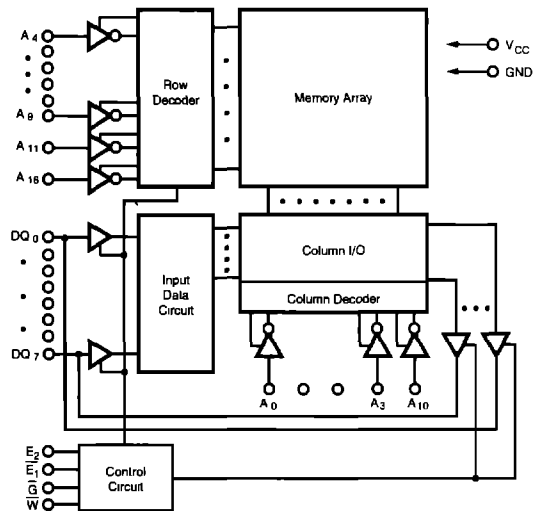

MS621000

PIN DESCRIPTIONS

$A_0 - A_{16}$ Address Inputs

These 17 address inputs select one of the 131,072 x 8-bit words in the RAM.

\bar{E}_1 Chip Enable 1 Input

E_2 Chip Enable 2 Input

\bar{E}_1 is active LOW and E_2 is active HIGH. Both chip enables must be active to read from or write to the device. If either chip enable is not active, the device is deselected and is in a standby power mode. The DQ pins will be in the high-impedance state when the device is deselected.

\bar{G} Output Enable Input

The output enable input is active LOW. If the output enable is active while the chip is selected and the write enable is inactive, data will be present on the DQ pins and they will be enabled. The DQ pins will be in the high impedance state when \bar{G} is inactive.

\bar{W} Write Enable Input

The write enable input is active LOW and controls read and write operations. With the chip selected, when \bar{W} is HIGH and \bar{G} is LOW, output data will be present at the DQ pins; when \bar{W} is LOW, the data present on the DQ pins will be written into the selected memory location.

DQ₀ - DQ₇ Data Input/Output Ports

These 8 bidirectional ports are used to read data from or write data into the RAM

V_{CC} Power Supply

GND Ground

TRUTH TABLE

MODE	\bar{W}	\bar{E}_1	E_2	\bar{G}	I/O OPERATION	V_{CC} CURRENT
Not Selected (Power Down)	X	H	X	X	High Z	I_{CCSB}, I_{CCSB1}
	X	X	L	X	High Z	I_{CCSB}, I_{CCSB1}
Output Disabled	H	L	H	H	High Z	I_{CC}
Read	H	L	H	L	D_{OUT}	I_{CC}
Write	L	L	H	X	D_{IN}	I_{CC}

ABSOLUTE MAXIMUM RATINGS ⁽¹⁾

SYMBOL	PARAMETER	RATING	UNITS
V_{TERM}	Terminal Voltage with Respect to GND	-0.5 to +7.0	V
T_{BIAS}	Temperature Under Bias	-10 to +85	°C
T_{STG}	Storage Temperature	-45 to +125	°C

- ¹ Stresses greater than those listed under ABSOLUTE MAXIMUM RATINGS may cause permanent damage to the device. This is a stress rating only and functional operation of the device at these or any other conditions above those indicated in the operational sections of this specification is not implied. Exposure to absolute maximum rating conditions for extended periods may affect reliability.

OPERATING RANGE

RANGE	TEMPERATURE	V_{CC}
Commercial	0°C to +70°C	5V ± 10%

CAPACITANCE ⁽¹⁾ ($T_A = 25^\circ\text{C}$, $f = 1.0\text{MHz}$)

SYMBOL	PARAMETER	CONDITIONS	MAX.	UNIT
C_{IN}	Input Capacitance	$V_{IN} = 0V$	8	pF
C_{DQ}	Input/Output Capacitance	$V_{IO} = 0V$	10	pF

- ¹ This parameter is guaranteed and not tested

DC ELECTRICAL CHARACTERISTICS (over the operating range)

PARAMETER NAME	PARAMETER	TEST CONDITIONS	MS621000			MS621000L			UNITS
			MIN.	TYP. ⁽¹⁾	MAX.	MIN.	TYP. ⁽¹⁾	MAX.	
V_{IL}	Guaranteed Input Low Voltage ⁽²⁾		-0.3	-	+0.8	-0.3	-	+0.8	V
V_{IH}	Guaranteed Input High Voltage ⁽²⁾		2.2	-	$V_{CC} + 0.3$	2.2	-	$V_{CC} + 0.3$	V
I_{IL}	Input Leakage Current	$V_{CC} = \text{Max}, V_{IN} = 0V \text{ to } V_{CC}$	-1	-	1	-1	-	1	μA
I_{OL}	Output Leakage Current	$V_{CC} = \text{Max}, \bar{E}_1 = V_{IH}, \text{ or } E_2 = V_{IL}, \text{ or } \bar{G} = V_{IH}, V_{IN} = 0V \text{ to } V_{CC}$	-2	-	2	-2	-	2	μA
V_{OL}	Output Low Voltage	$V_{CC} = \text{Min}, I_{OL} = 4\text{mA}$	-	-	0.4	-	-	0.4	V
V_{OH}	Output High Voltage	$V_{CC} = \text{Min}, I_{OH} = -1\text{mA}$	2.4	-	-	2.4	-	-	V
I_{CC}	Operating Power Supply Current	$V_{CC} = \text{Max}, E_1 = V_{IL}, E_2 = V_{IH}, I_{DQ} = 0\text{mA}, F = F_{\text{max}}^{(3)}$	-	-	80	-	-	80	mA
I_{CCSB}	Standby Power Supply Current	$V_{CC} = \text{Max}, E_1 = V_{IH}, \text{ or } E_2 = V_{IL}, I_{DQ} = 0\text{mA}$	-	-	3	-	-	3	mA
I_{CCSB1}	Power Down Power Supply Current	$V_{CC} = \text{Max}, \bar{E}_1 \geq V_{CC} - 0.2V, E_2 \leq 0.2V, V_{IN} \geq V_{CC} - 0.2V \text{ or } V_{IN} \leq 0.2V$	-	-	1	-	-	0.2	mA

1. Typical characteristics are at $V_{CC} = 5V, T_A = 25^\circ\text{C}$
2. These are absolute values with respect to device ground and all overshoots due to system or tester noise are included
3. $F_{\text{max}} = 1/t_{RC}$

DATA RETENTION CHARACTERISTICS ($T_A = 0 \text{ to } +70^\circ\text{C}$)

SYMBOL	PARAMETER	TEST CONDITIONS	MIN.	TYP. ⁽¹⁾	MAX.	UNITS	
V_{DR}	V_{CC} for Data Retention	$E_1 \geq V_{CC} - 0.2V, E_2 \leq 0.2V, V_{IN} \geq V_{CC} - 0.2V \text{ or } V_{IN} \leq 0.2V$	2.0	-	5.5	V	
$I_{CCDR}^{(1)}$	Data Retention Current	MS621000	Standard	-	-	0.5	mA
		MS621000L	L-Version	-	-	0.1	mA
t_{CDR}	Chip Deselect to Data Retention Time	See Retention Waveform	0	-	-	ns	
t_R	Operation Recovery Time		$t_{RC}^{(2)}$	-	-	ns	

1. $V_{CC} = V_{DR} = 3V$
 $\bar{E}_1 \geq V_{DR} = 0.2V, E_2 \geq V_{DR} - 0.2V \text{ or } E_2 \leq 0.2V$ (at E_1 controlled)
2. t_{RC} Read Cycle Time

LOW V_{CC} DATA RETENTION WAVEFORM (1) (\bar{E}_1 Controlled)

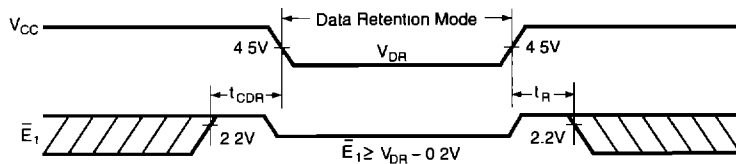

LOW V_{CC} DATA RETENTION WAVEFORM (2) (E_2 Controlled)

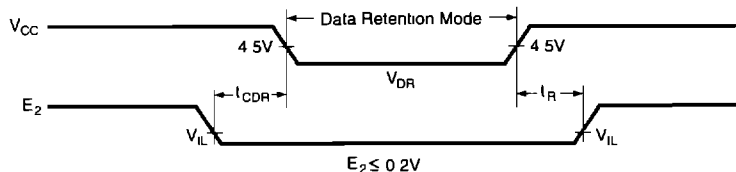

MS621000

AC TEST CONDITIONS

Input Pulse Levels	0.6V to 2.4V
Input Rise and Fall Times	5ns
Input and Output	Input $V_{IL} = 0.8V$, $V_{IH} = 2.2V$
Timing Reference Level	Output: $V_{OL} = 0.8V$, $V_{OH} = 2.0V$

KEY TO SWITCHING WAVEFORMS

WAVEFORM	INPUTS	OUTPUTS
	MUST BE STEADY	WILL BE STEADY
	MAY CHANGE FROM H TO L	WILL BE CHANGING FROM H TO L
	MAY CHANGE FROM L TO H	WILL BE CHANGING FROM L TO H
	DON'T CARE ANY CHANGE PERMITTED	CHANGING STATE UNKNOWN
	DOES NOT APPLY	CENTER LINE IS HIGH IMPEDANCE *OFF* STATE

AC TEST LOADS AND WAVEFORMS

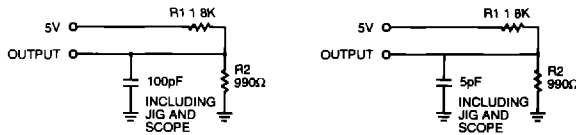
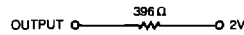

Figure 1a

Figure 1b

Equivalent to

THEVENIN EQUIVALENT



ALL INPUT PULSES

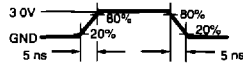

Figure 2

AC ELECTRICAL CHARACTERISTICS (over the operating range)

READ CYCLE

JEDEC PARAMETER NAME	PARAMETER NAME	PARAMETER	MS621000/L -80			MS621000/L -10			MS621000/L -12			UNIT	
			MIN.	TYP.	MAX.	MIN.	TYP.	MAX.	MIN.	TYP.	MAX.		
t_{AVAX}	t_{RC}	Read Cycle Time	80	-	-	100	-	-	120	-	-	ns	
t_{AVQV}	t_{AA}	Address Access Time	-	-	80	-	-	100	-	-	120	ns	
t_{E1LQV}	t_{ACS1}	Chip Select Access Time	E_1	-	80	-	-	100	-	-	120	ns	
t_{E2HQV}	t_{ACS2}	Chip Select Access Time	E_2	-	80	-	-	100	-	-	120	ns	
t_{GLQV}	t_{OE}	Output Enable to Output Valid	-	-	35	-	-	40	-	-	50	ns	
t_{E1LQX}	t_{CLZ1}	Chip Select to Output Low Z	\bar{E}_1	10	-	-	10	-	-	10	-	ns	
t_{E2HQX}	t_{CLZ2}	Chip Select to Output Low Z	E_2	10	-	-	10	-	-	10	-	ns	
t_{GLQX}	t_{OLZ}	Output Enable to Output in Low Z	-	5	-	-	5	-	-	5	-	ns	
t_{E1HQZ}	t_{CHZ1}	Chip Deselect to Output in High Z	\bar{E}_1	-	-	30	-	-	35	-	-	40	ns
t_{E2HQZ}	t_{CHZ2}	Chip Deselect to Output in High Z	E_2	-	-	30	-	-	35	-	-	40	ns
t_{GHQZ}	t_{OHZ}	Output Disable to Output in High Z	-	-	30	-	-	30	-	-	40	ns	
t_{AXQX}	t_{OH}	Output Hold from Address Change	-	10	-	-	10	-	-	10	-	ns	

SWITCHING WAVEFORMS (READ CYCLE)

READ CYCLE 1^(1,2,4)

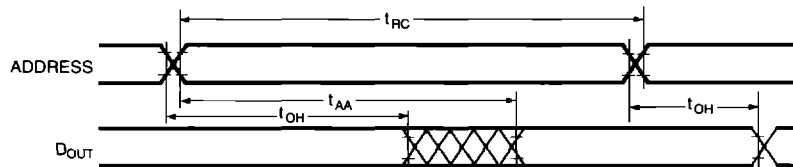

READ CYCLE 2^(1,3,4)

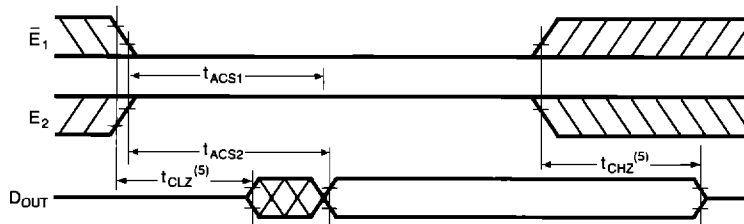

READ CYCLE 3^(1,4)

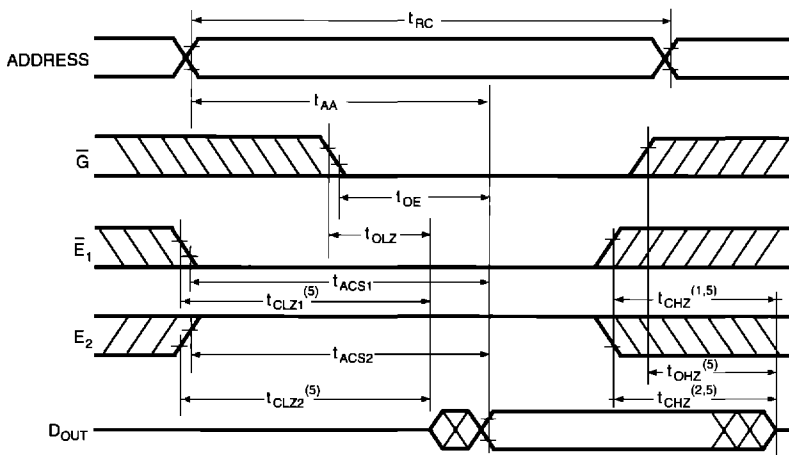

NOTES:

- 1 \bar{W} is high for READ Cycle.
- 2 Device is continuously selected $\bar{E}_1 = V_{IL}$ and $E_2 = V_{IH}$.
- 3 Address valid prior to or coincident with \bar{E}_1 transition low and/or E_2 transition high.
- 4 $\bar{G} = V_{IL}$.
- 5 Transition is measured $\pm 500mV$ from steady state with $C_L = 5pF$ as shown in Figure 1b. This parameter is guaranteed but not 100% tested.

MS621000

AC ELECTRICAL CHARACTERISTICS (over the operating range)

WRITE CYCLE

JEDEC PARAMETER NAME	PARAMETER NAME	PARAMETER	MS621000L -80			MS621000L -10			MS621000L -12			UNIT
			MIN.	TYP.	MAX.	MIN.	TYP.	MAX.	MIN.	TYP.	MAX.	
t_{AVAX}	t_{WC}	Write Cycle Time	80	-	-	100	-	-	120	-	-	ns
t_{E1LWH}	t_{CW}	Chip Select to End of Write	60	-	-	80	-	-	85	-	-	ns
t_{AVWL}	t_{AS}	Address Set up Time	0	-	-	0	-	-	0	-	-	ns
t_{AVWH}	t_{AW}	Address Valid to End of Write	60	-	-	80	-	-	85	-	-	ns
t_{WLWH}	t_{WP}	Write Pulse Width	50	-	-	60	-	-	70	-	-	ns
t_{WHAX}	t_{WR1}	Write Recovery Time \bar{E}_1, \bar{W}	5	-	-	5	-	-	5	-	-	ns
t_{E2LAX}	t_{WR2}	Write Recovery Time E_2	5	-	-	5	-	-	5	-	-	ns
t_{WLQZ}	t_{WHZ}	Write to Output in High Z	-	-	30	-	-	35	-	-	40	ns
t_{DVWH}	t_{DW}	Data to Write Time Overlap	30	-	-	40	-	-	45	-	-	ns
t_{WHDX}	t_{DH}	Data Hold from Write Time	0	-	-	0	-	-	0	-	-	ns
t_{GHQZ}	t_{OHZ}	Output Disable to Output in High Z	-	-	30	-	-	35	-	-	40	ns
t_{WHQX}	t_{OW}	End of Write to Output Active	5	-	-	5	-	-	5	-	-	ns

SWITCHING WAVEFORMS (WRITE CYCLE)

WRITE CYCLE 1⁽¹⁾

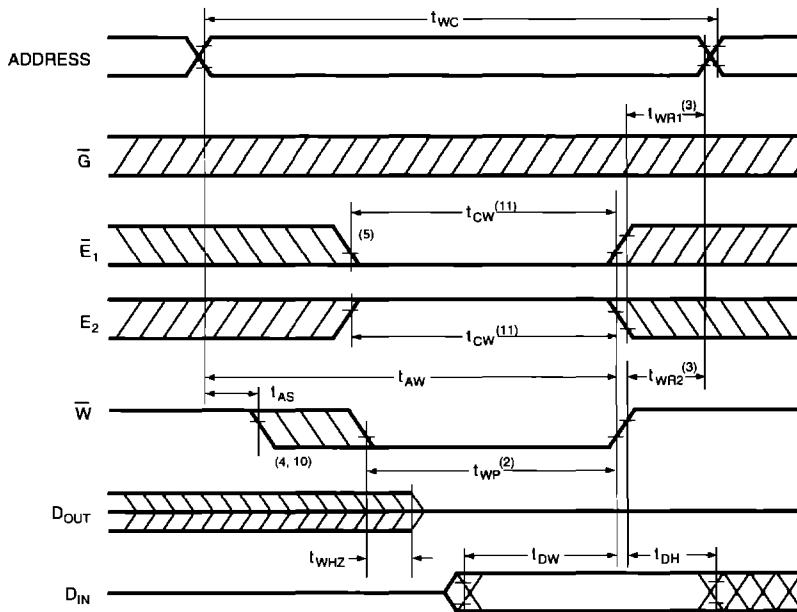

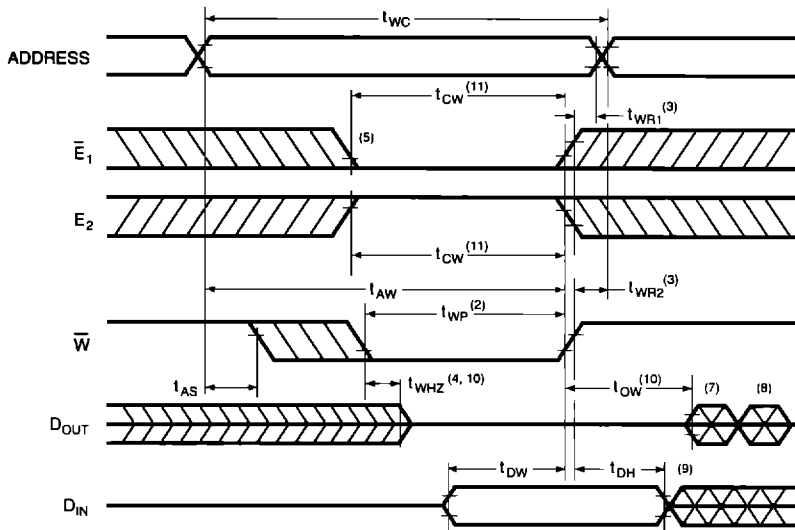
WRITE CYCLE 2^(1,8)

3

NOTES

- \bar{W} must be high during address transitions
- The internal write time of the memory is defined by the overlap of \bar{E}_1 and E_2 active and \bar{W} low. All signals must be active to initiate a write and any one signal can terminate a write by going inactive. The data input setup and hold timing should be referenced to the second transition edge of the signal that terminates the write.
- t_{WR} is measured from the earlier of \bar{E}_1 or \bar{W} going high or E_2 going low at the end of write cycle.
- During this period, DQ pins are in the output state so that the input signals of opposite phase to the outputs must not be applied.
- If the \bar{E}_1 low transition or the E_2 high transition occurs simultaneously with the \bar{W} low transitions or after the \bar{W} transition, outputs remain in a high impedance state.
- \bar{G} is continuously low ($\bar{G} = V_L$)
- D_{OUT} is the same phase of write data of this write cycle.
- D_{OUT} is the read data of next address.
- If \bar{E}_1 is low and E_2 is high during this period, DQ pins are in the output state. Then the data input signals of opposite phase to the outputs must not be applied to them.
- Transition is measured $\pm 500mV$ from steady state with $C_L = 5pF$ as shown in Figure 1b. This parameter is guaranteed but not 100% tested.
- t_{CW} is measured from the later of \bar{E}_1 going low or E_2 going high to the end of write.

MS621000

ORDERING INFORMATION

SPEED (ns)	ORDERING PART NUMBER	PACKAGE REFERENCE NO.	TEMPERATURE RANGE
80	MS621000-80PC	P32-2	0°C to +70°C
80	MS621000-80FC	S32-1	0°C to +70°C
80	MS621000L-80PC	P32-2	0°C to +70°C
80	MS621000L-80FC	S32-1	0°C to +70°C
100	MS621000-10PC	P32-2	0°C to +70°C
100	MS621000-10FC	S32-1	0°C to +70°C
100	MS621000L-10PC	P32-2	0°C to +70°C
100	MS621000L-10FC	S32-1	0°C to +70°C
120	MS621000-12PC	P32-2	0°C to +70°C
120	MS621000-12FC	S32-1	0°C to +70°C
120	MS621000L-12PC	P32-2	0°C to +70°C
120	MS621000L-12FC	S32-1	0°C to +70°C