

January 1989

Features

- This Circuit is Processed in Accordance to Mil-Std-883 and is Fully Conformant Under the Provisions of Paragraph 1.2.1.
- Digital Programmability
- High Slew Rate (U_{in} uncompensated) 20V/ μ s Min
(Compensated) 6V/ μ s Min
- Wide Gain Bandwidth
(Uncompensated) 20MHz Min
(Compensated) 4MHz Min
- High Gain 50kV/V Min
- Low Offset Current 50nA Max
- Single Capacitor Compensation For Unity Gain
- DTL/TTL Compatible Inputs

Applications

- Single Selection/Multiplexing
- Op Amp Gain Stage
- Frequency Oscillator
- Filter Characteristics
- Add-Subtract Functions
- Integrator Characteristics
- Comparator Levels

Description

The HA-2400/883 is a four channel programmable amplifier providing a level of versatility unsurpassed by any other monolithic operational amplifier. Versatility is achieved by employing four input amplifier channels, any one (or none) of which may be electronically selected and connected to a single output stage through DTL/TTL compatible address inputs. The device formed by the output and the selected pair of inputs is an op amp which delivers excellent slew rate, gain bandwidth and power bandwidth performance. Other advantages features for these dielectrically isolated amplifiers include high voltage gain and input impedance coupled with low input offset voltage and offset current. External compensation is not required on this device at closed loop gains greater than 10.

Each channel of the HA-2400/883 can be controlled and operated with suitable feedback networks in any of the standard op amp configurations. This specialization makes these amplifiers excellent components for multiplexing, signal selection, and mathematical function designs. With 20V/ μ s slew rate, 20MHz gain bandwidth, and low input bias currents makes these devices ideal building blocks for signal generators, active filters, and data acquisition designs. Programmability coupled with 9mV maximum offset voltage and 50nA offset current makes these amplifiers outstanding components for the signal conditioning circuits.

The HA-2400/883 is available in the 16 pin Dual-in-Line Ceramic package and a 20 pin LCC package. The HA-2400/883 is specified from -55°C to +125°C.

Pinouts

HA1-2400/883 (CERAMIC DIP)
TOP VIEW

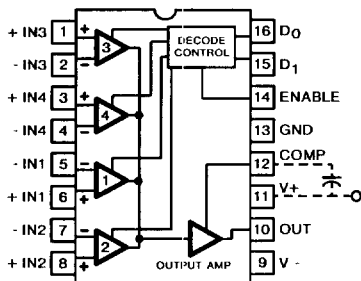

HA4-2400/883 (CERAMIC LCC)
TOP VIEW

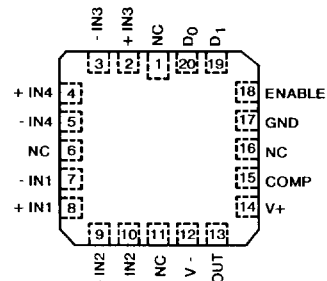

TRUTH TABLE

D ₁	D ₀	EN	SELECTED CHANNEL
L	L	H	1
L	H	H	2
H	L	H	3
H	H	H	4
X	X	L	NONE

Specifications HA-2400/883

Absolute Maximum Ratings

Voltage Between V+ and V- Terminals	45V
Differential Input Voltage	$\pm V_{SUPPLY}$
Voltage at Either Input Terminal	V+ to V-
Digital Input Voltage	-0.76V to +10V
Peak Output Current (Short Circuit Protected)	$I_{SC} < \pm 33mA$
Junction Temperature (T_J)	+175°C
Storage Temperature Range	-65°C to +150°C
ESD Rating	<2000V
Lead Temperature (Soldering 10 sec)	+275°C

CAUTION: Absolute maximum ratings are limiting values, applied individually beyond which the serviceability of the circuit may be impaired. Functional operability under any of these conditions is not necessarily implied.

Thermal Information

Thermal Resistance	θ_{ja}	θ_{jc}
Ceramic DIP Package	91°C/W	25°C/W
Ceramic LCC Package	88°C/W	28°C/W
Internal Power Dissipation	Package Power Dissipation Limit at +75°C for $T_J \leq +175^\circ C$	
Ceramic DIP Package	1.11W	
Ceramic LCC Package	1.14W	
Package Power Dissipation Derating Factor Above +75°C	Ceramic DIP Package	
Ceramic DIP Package	11.1mW/°C	
Ceramic LCC Package	11.4mW/°C	

Recommended Operating Conditions

Operating Temperature Range	-55°C to +125°C	Negative Supply Voltage	-15V
Operating Supply Voltage	+15V		

TABLE 1. D.C. ELECTRICAL PERFORMANCE CHARACTERISTICS

Device Tested at: V+ = +15V, V- = -15V, $R_S = 100\Omega$, $R_L = 500k\Omega$, $V_O = 0V$ Unless Otherwise Specified.

Digital Inputs: $V_{IL} = +0.5V$, $V_{IH} = +2.4V$, Limits Apply to Each of the Four Channels, When Addressed.

D.C. PARAMETERS	SYMBOL	CONDITIONS	GROUP A SUBGROUP	TEMPERATURE	LIMITS		UNITS
					MIN	MAX	
Offset Voltage	V_{IO}	$V_{CM} = 0V$	1	+25°C	-9	9	mV
			2,3	+125°C, -55°C	-11	11	mV
Input Bias Current	+I _B	$V_{CM} = 0V$ $+R_S = 100k\Omega$ $-R_S = 100\Omega$	1	+25°C	-200	200	nA
			2,3	+125°C, -55°C	-400	400	nA
	-I _B	$V_{CM} = 0V$ $+R_S = 100\Omega$ $-R_S = 100k\Omega$	1	+25°C	-200	200	nA
			2,3	+125°C, -55°C	-400	400	nA
Input Offset Current	I_{IO}	$V_{CM} = 0V$ $+R_S = 100k\Omega$ $-R_S = 100k\Omega$	1	+25°C	-50	50	nA
			2,3	+125°C, -55°C	-100	100	nA
Common Mode Range	+CMR	V+ = +6V V- = -24V V _{OUT} = -9V	1	+25°C	9	-	V
			2,3	+125°C, -55°C	9	-	V
	-CMR	V+ = +24V V- = -6V V _{OUT} = +9V	1	+25°C	-	-9	V
			2,3	+125°C, -55°C	-	-9	V
Large Signal Voltage Gain	A_V	V _{OUT} = -10V to +10V $R_L = 2k\Omega$	4	+25°C	50	-	kV/V
			5,6	+125°C, -55°C	25	-	kV/V
Common Mode Rejection Ratio	+CMRR	$\Delta V_{CM} = +5V$ +V = +10V -V = -20V V _{OUT} = -5V	1	+25°C	80	-	dB
			2,3	+125°C, -55°C	80	-	dB
	-CMRR	$\Delta V_{CM} = -5V$ +V = +20V -V = -10V V _{OUT} = +5V	1	+25°C	80	-	dB
			2,3	+125°C, -55°C	80	-	dB
Output Voltage Swing	+V _{OUT}	$R_L = 2k\Omega$	4	+25°C	+10	-	V
			5,6	+125°C, -55°C	+10	-	V
	-V _{OUT}	$R_L = 2k\Omega$	4	+25°C	-	-10	V
			5,6	+125°C, -55°C	-	-10	V

CAUTION: This device is sensitive to electrostatic discharge. Proper I.C. handling procedures should be followed.

Specifications HA-2400/883

TABLE 1. D.C. ELECTRICAL PERFORMANCE CHARACTERISTICS (Continued)

Device Tested at: $V_+ = +15V$, $V_- = -15V$, $R_S = 100\Omega$, $R_L = 500k\Omega$, $V_O = 0V$ Unless Otherwise Specified.
 Digital Inputs: $V_{IL} = +0.5V$, $V_{IH} = +2.4V$, Limits Apply to Each of the Four Channels, When Addressed

PARAMETER	SYMBOL	CONDITIONS	GROUP A SUBGROUP	TEMPERATURE	LIMITS		UNITS
					MIN	MAX	
Output Current	+I _{OUT}	V _{OUT} = +10V	4	+25°C	+10	-	mA
	-I _{OUT}	V _{OUT} = -10V	4	+25°C	-	-10	mA
Supply Current	+I _{CC}	V _{OUT} = 0V	1	+25°C	-	6	mA
			2,3	+125°C, -55°C	-	7	mA
	-I _{CC}	V _{OUT} = 0V	1	+25°C	-6	-	mA
			2,3	+125°C, -55°C	-7	-	mA
Power Supply Rejection Ratio	+PSRR	$\Delta V_{SUP} = \pm 5V$ $V_+ = +20V, V_- = -15V$ $V_+ = +10V, V_- = -15V$	1	+25°C	74	-	dB
			2,3	+125°C, -55°C	74	-	dB
	-PSRR	$\Delta V_{SUP} = \pm 5V$ $V_+ = +15V, V_- = -20V$ $V_+ = +15V, V_- = -10V$	1	+25°C	74	-	dB
			2,3	+125°C, -55°C	74	-	dB
Crosstalk	C _T	V _{IN} = ±10V	1	+25°C	-80	-	dB
Digital Logic Current	I _{IL}	V _{IL} = 0V	1	+25°C	-	1.5	mA
			2,3	+125°C, -55°C	-	1.5	mA
	I _{IH}	V _{IH} = 5.0V	1	+25°C	-	1	μA
			2,3	+125°C, -55°C	-	1	μA

TABLE 2. A.C. ELECTRICAL PERFORMANCE CHARACTERISTICS

Device Tested at: $V_+ = +15V$, $V_- = -15V$, $R_L = 2k\Omega$, $C_{LOAD} = 50pF$, Unless Otherwise Specified.
 Subscript 1 Refers to A_y = +1, C_{COMP} = 15pF
 Digital Inputs: $V_{IL} = +0.5V$, $V_{IH} = +2.4V$, Limits Apply to Each of the Four Channels, When Addressed.

PARAMETERS	SYMBOL	CONDITIONS	GROUP A SUBGROUP	TEMPERATURE	LIMITS		UNITS
					MIN	MAX	
Slew Rate ₁	+SR ₁	V _{OUT} = -5V to +5V	7	+25°C	6	-	V/μs
	-SR ₁	V _{OUT} = +5V to -5V	7	+25°C	6	-	V/μs
Rise & Fall Time	TR ₁	V _{OUT} = 0 to +200mV	7	+25°C	-	45	ns
	TF ₁	V _{OUT} = 0 to -200mV	7	+25°C	-	45	ns
Overshoot	+OS ₁	V _{OUT} = 0 to +200mV	7	+25°C	-	40	%
	-OS ₁	V _{OUT} = 0 to -200mV	7	+25°C	-	40	%

CAUTION: This device is sensitive to electrostatic discharge. Proper I.C. handling procedures should be followed.

Specifications HA-2400/883

TABLE 3. ELECTRICAL PERFORMANCE CHARACTERISTICS

Device Characterized at: $V_+ = +15V$, $V_- = -15V$, Unless Otherwise Specified.
Subscript 2 Refers to $A_V = +10$, $C_{COMP} = 0pF$

PARAMETERS	SYMBOL	CONDITIONS	NOTES	TEMPERATURE	LIMITS		UNITS
					MIN	MAX	
Unity Gain Bandwidth	UGBW ₁	$A_V = +1$, $C_{COMP} = 15pF$ $R_L = 2k\Omega$, $C_L = 50pF$	1	+25°C	4	-	MHz
Gain Bandwidth Product	GBWP ₂	$A_V = +10$, $C_{COMP} = 0pF$ $R_L = 2k\Omega$, $C_L = 50pF$	1	+25°C	20	-	MHz
Full Power Bandwidth ₁	FPBW ₁	$R_L = 2k\Omega$, $A_V = +1V$, $V_O = \pm 10V$, $C_L = 50pF$, $C_{COMP} = 15pF$	1, 2	+25°C	95	-	kHz
Full Power Bandwidth ₂	FPBW ₂	$R_L = 2k\Omega$, $A_V = +10V$, $V_O = \pm 10V$, $C_L = 50pF$, $C_{COMP} = 0pF$	1, 2	+25°C	300	-	kHz
Settling Time	TSET ₁	$A_V = +1$, $C_{COMP} = 15pF$ $R_L = 2k\Omega$, $C_L = 50pF$, $V_O = 10V_{p-p}$ to 0.1% F.V. Logic Control = +5.0V	1	+25°C	-	2.5	μs
Slew Rate ₂	+SR ₂	$V_{OUT} = -5V$ to $+5V$ $R_L = 2k\Omega$, $C_L = 50pF$, $A_V = +10$, $C_{COMP} = 0pF$	1	+25°C	20	-	V/ μs
	-SR ₂	$V_{OUT} = +5V$ to $-5V$ $R_L = 2k\Omega$, $C_L = 50pF$, $A_V = +10$, $C_{COMP} = 0pF$	1	+25°C	20	-	V/ μs
Output Delay	TDEL	$R_L = 2k\Omega$, $C_L = 50pF$, $C_{COMP} = 15pF$, $V_{IN} = +5V$	1	+25°C	-	250	ns
Minimum Closed Loop Stability	CLS ₁	$R_L = 2k\Omega$, $C_L = 50pF$, $C_{COMP} = 15pF$	1	+25°C	1	-	V/V
	CLS ₂	$R_L = 2k\Omega$, $C_L = 50pF$, $C_{COMP} = 0pF$	1	+25°C	10	-	V/V

NOTES: 1. The parameters listed in this table are controlled via design or process parameters and are not directly tested at final production. These parameters are lab characterized upon initial design release, or upon design changes. These parameters are guaranteed by characterization based upon data from multiple production runs which reflect lot to lot and within lot variation.

2. $FPBW = \frac{S.R.}{2\pi V_{peak}}$

TABLE 4. ELECTRICAL TEST REQUIREMENTS

MIL-STD-883 TEST REQUIREMENTS	SUBGROUPS (SEE TABLES 1 & 2)
Interim Electrical Parameters (Pre Burn-In)	1
Final Electrical Test Parameters	1*, 2, 3, 4, 5, 6, 7
Group A Test Requirements	1, 2, 3, 4, 5, 6, 7
Groups C & D Endpoints	1

* PDA applies to Subgroup 1 only.

The subgroup assignments of the parameters in these tables were patterned after DESC SMD #5962-87783.

CAUTION: This device is sensitive to electrostatic discharge. Proper I.C. handling procedures should be followed.

Test Circuit

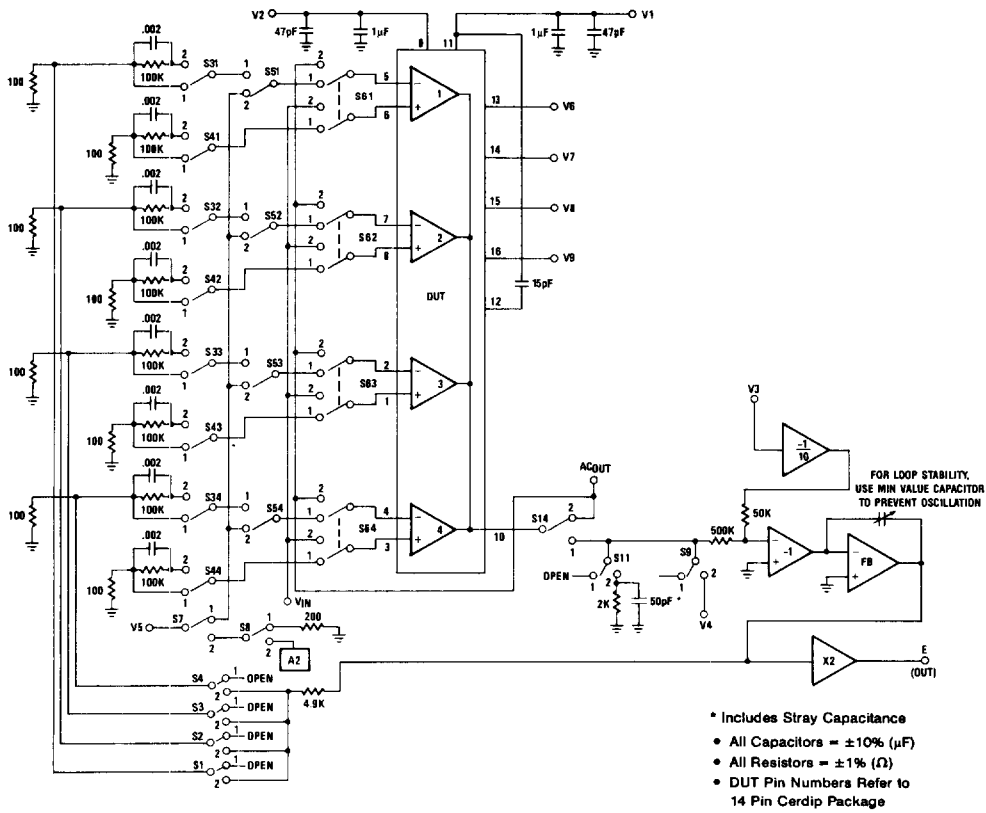

For Detailed Information, Refer to HA-2400/883 Test Tech Brief

Test Waveforms

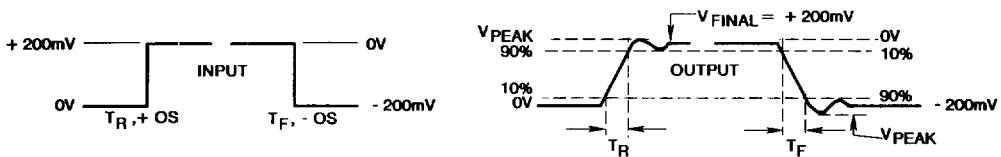
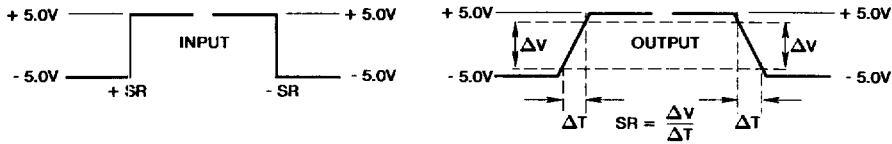

3
 OP AMPS &
 COMPARATORS

HA-2400/883

Burn-In Circuits

HA-2400/883 CERAMIC DIP

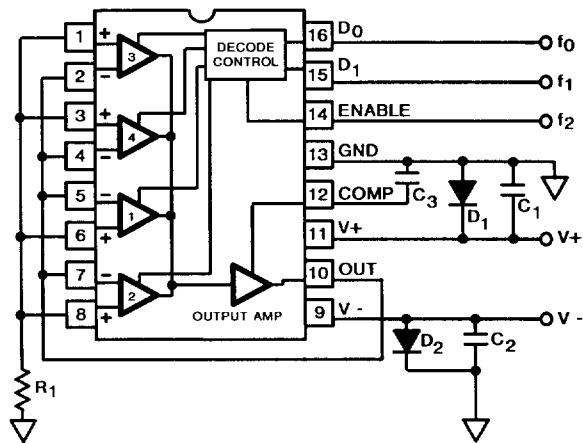

HA-2400/883 CERAMIC LCC

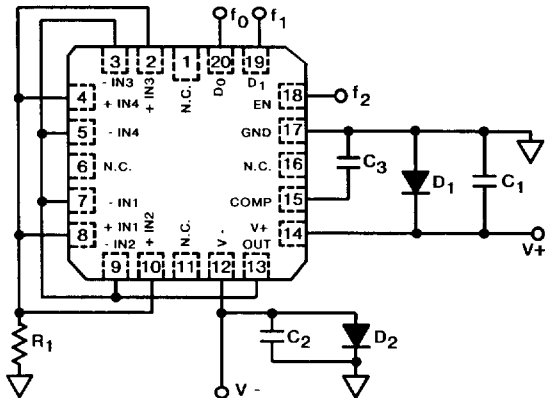

NOTES:

- R₁ = 100kΩ/Socket, 5%, 1/4W (Min)
- C₁ = C₂ = 0.01μF/Socket (Min) or 0.1μF/Row (Min)
- C₃ = 0.001μF/Socket, 10%
- D₁ = D₂ = 1N4002 or Equivalent/Board
- |V₊ - V₋| = 30V

- f₀ = 100kHz
- f₁ = 50kHz
- f₂ = 25kHz

50% Duty Cycle

Schematic Diagram

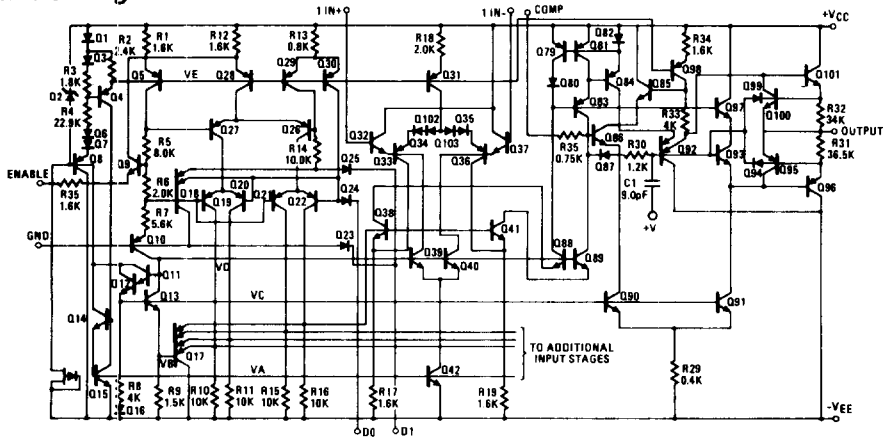

Die Characteristics

DIE DIMENSIONS:

88 x 67 x 19 mils
(2240 x 1710 x 483µm)

METALLIZATION:

Type: Aluminum
Thickness: 16kÅ ± 2kÅ

GLASSIVATION:

Type: Nitride
Thickness: 7kÅ ± 0.7kÅ

SUBSTRATE POTENTIAL (POWERED UP): Unbiased

DIE ATTACH:

Material: Gold/Silicon Eutectic Alloy
Temperature: Ceramic DIP — 460°C (Max)
Ceramic LCC — 420°C (Max)

WORST CASE CURRENT DENSITY:

0.7 x 10⁵A/cm²

ACTIVE DEVICE COUNT: 251

Metallization Mask Layout

HA-2400/883

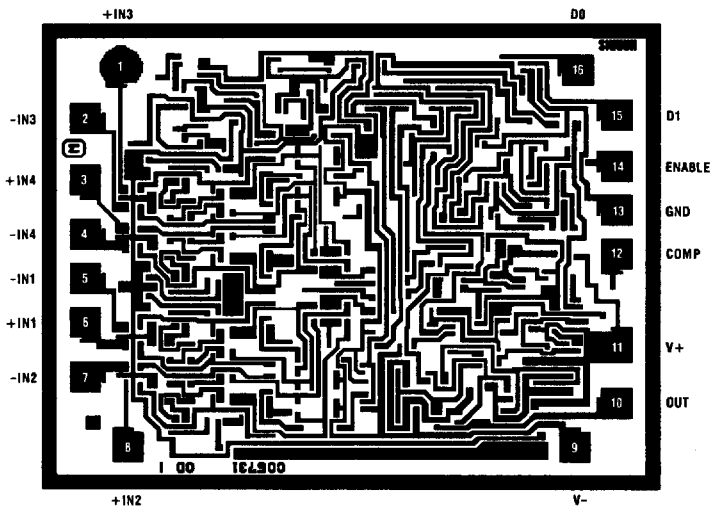

NOTE: Pin Numbers Correspond to DIP Package Only.

Packaging†

16 PIN CERAMIC DIP

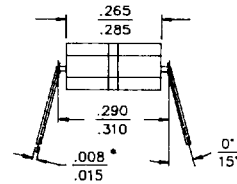
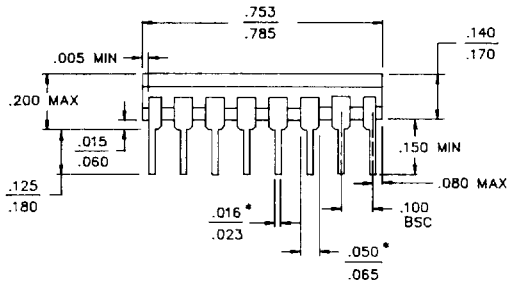

• INCREASE MAX LIMIT BY .003 INCHES MEASURED AT CENTER OF FLAT FOR SOLDER FINISH

LEAD MATERIAL: Type B
LEAD FINISH: Type A
PACKAGE MATERIAL: Ceramic, 90% Alumina
PACKAGE SEAL:
 Material: Glass Frit
 Temperature: 450°C ± 10°C
 Method: Furnace Seal

INTERNAL LEAD WIRE:
 Material: Aluminum
 Diameter: 1.25 Mil
 Bonding Method: Ultrasonic
COMPLIANT OUTLINE: 38510 D-2

20 PAD CERAMIC LCC

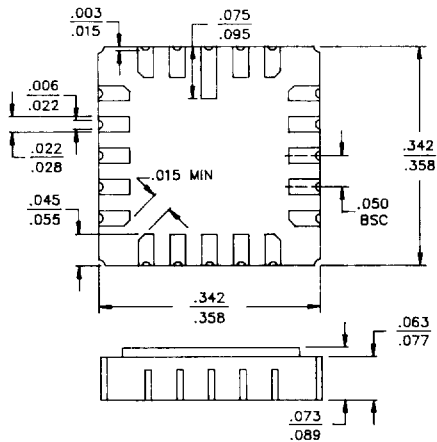

PAD MATERIAL: Type C
PAD FINISH: Type A
FINISH DIMENSION: Type A
PACKAGE MATERIAL: Multilayer Ceramic, 90% Alumina
PACKAGE SEAL:
 Material: Gold/Tin (80/20)
 Temperature: 320°C ± 10°C
 Method: Furnace Braze

INTERNAL LEAD WIRE:
 Material: Aluminum
 Diameter: 1.25 Mil
 Bonding Method: Ultrasonic
COMPLIANT OUTLINE: 38510 C-2

NOTE: All Dimensions are $\frac{\text{Min}}{\text{Max}}$, Dimensions are in inches.

† Mil-M-38510 Compliant Materials, Finishes, and Dimensions.

DESIGN INFORMATION
**PRAM Four Channel
Programmable Operational Amplifier**

The information contained in this section has been developed through characterization by Harris Semiconductor and is for use as application and design aid only. These characteristics are not 100% tested and no product guarantee is implied.

TYPICAL PERFORMANCE CHARACTERISTICS

Devices Characterized at: $V_S = \pm 15V$, $V_{IL} = +0.5V$, $V_{IH} = +2.4V$. Values Apply to Each of Four Channels When Addressed.

PARAMETERS	CONDITIONS	TEMP	TYP	UNITS
Offset Voltage	$V_{CM} = 0V$	+25°C	4	mV
Bias Current	$V_{CM} = 0V$	+25°C	50	nA
Offset Current	$V_{CM} = 0V$	+25°C	5	nA
Input Resistance		+25°C	30	MΩ
Large Signal Voltage Gain	$R_L = 2k\Omega$, $V_O = 20V_{p-p}$	+25°C	150	kV/V
Common Mode Rejection Ratio	$V_{CM} = \pm 5VDC$	Full	100	dB
Gain Bandwidth Product	$R_L = 2k\Omega$, $C_L = 50pF$, $C_{COMP} = 0pF$, $A_V = +10$	+25°C	40	MHz
Unity Gain Bandwidth	$R_L = 2k\Omega$, $C_L = 50pF$, $C_{COMP} = 15pF$, $A_V = +1$	+25°C	8	MHz
Output Voltage Swing	$R_L = 2k\Omega$	Full	± 12	V
Output Current	$V_{OUT} = \pm 10V$	+25°C	20	mA
FPBW ₁	Note 2, $V_p = 10V$	+25°C	475	kHz
FPBW ₂	Note 2, $V_p = 10V$	+25°C	125	kHz
Rise Time	$R_L = 2k\Omega$, $C_L = 50pF$, $C_{COMP} = 15pF$, $A_V = +1$	+25°C	20	ns
Overshoot	$R_L = 2k\Omega$, $C_L = 50pF$, $C_{COMP} = 15pF$, $A_V = +1$	+25°C	25	%
Slew Rate ₁	$A_V = +1V/V$	+25°C	8	V/μs
Slew Rate ₂	$A_V = +10V/V$	+25°C	30	V/μs
Settling Time ₁	$V_O = 10V_{p-p}$ to 0.1%	+25°C	1.5	μs
Digital Logic Current	$V_{IN} = +5.0V$	Full	5	nA
	$V_{IN} = 0V$	Full	1	mA
Output Delay	To 10% of Final Value	+25°C	100	ns
Crosstalk	Unselected Input to Output, $V_{IN} = \pm 10VDC$	+25°C	-110	dB
Supply Current	Not Loaded	+25°C	4.8	mA
PSRR	$\Delta V_S = \pm 10V$	Full	90	dB

DESIGN INFORMATION (Continued)

The information contained in this section has been developed through characterization by Harris Semiconductor and is for use as application and design aid only. These characteristics are not 100% tested and no product guarantee is implied.

Typical Performance Curves Unless Otherwise Specified: $V_{\pm} = \pm 15V$, $T_A = +25^{\circ}C$

INPUT BIAS CURRENT AND OFFSET CURRENT AS A FUNCTION OF TEMPERATURE

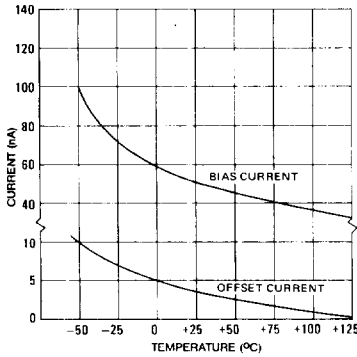

POWER SUPPLY CURRENT DRAIN AS A FUNCTION OF TEMPERATURE

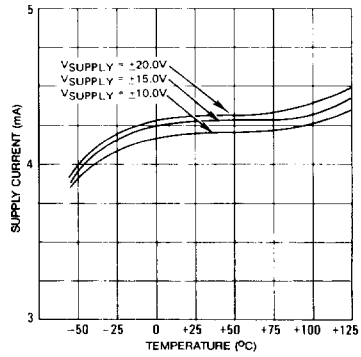

NORMALIZED A.C. PARAMETERS vs. TEMPERATURE

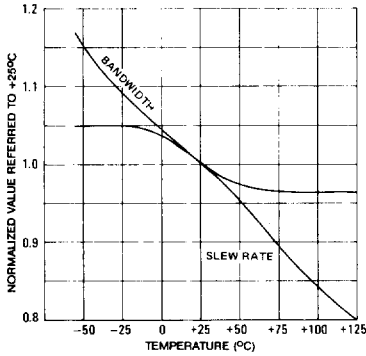

OPEN LOOP FREQUENCY AND PHASE RESPONSE

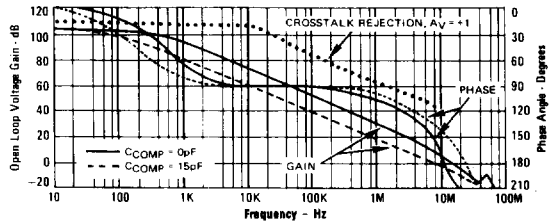

FREQUENCY RESPONSE vs. C_COMP

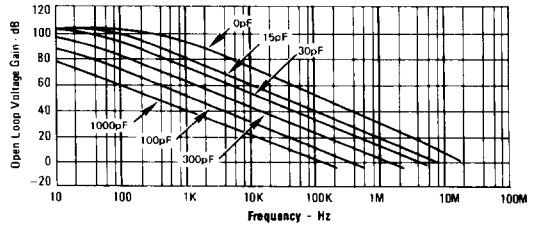

NORMALIZED A.C. PARAMETERS vs. SUPPLY VOLTAGE

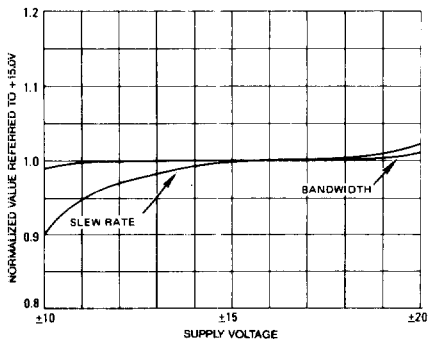

OPEN LOOP VOLTAGE GAIN vs. TEMPERATURE

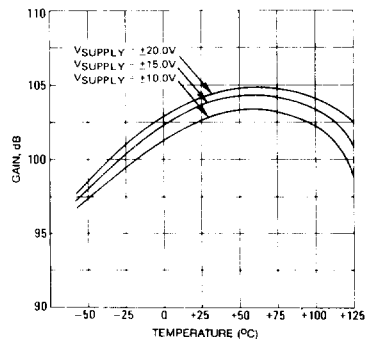

DESIGN INFORMATION (Continued)

The information contained in this section has been developed through characterization by Harris Semiconductor and is for use as application and design aid only. These characteristics are not 100% tested and no product guarantee is implied.

Typical Performance Curves Unless Otherwise Specified: $V_{\pm} = \pm 15V$, $T_A = +25^{\circ}C$

OUTPUT VOLTAGE SWING

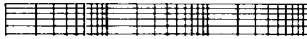

EQUIVALENT INPUT NOISE vs. BANDWIDTH

