

LOC	DIST	REVISIONS						
		P	LTR	DESCRIPTION	DATE	DWN	APVD	
A1	-		A	new drawing	11FEB2002	-	-	
			A1	ECR-06-024201	13.10.06	MD	LB	

Kontakt Contact	DGB (mm ²) Wire Range	Drahtcrimp/Wirecrimp		Isocrimp	Iso.-∅ Ins. Range	Dichtung Seal	Betriebsanl. Instr. Sheet
		Hoehe/Height	Breite/Width	Breite/Width			
183035 / 183036	0.35-0.5	1.00	2.03	4.06	1.4-1.7	281934-4	411-18228
183024 / 183025	0.75	1.29	2.29		1.8-3.3	281934-2	
	1.0	1.37					
	1.5	1.53					

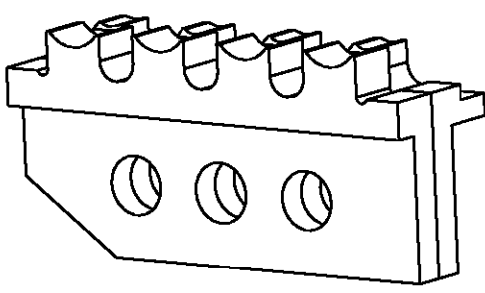
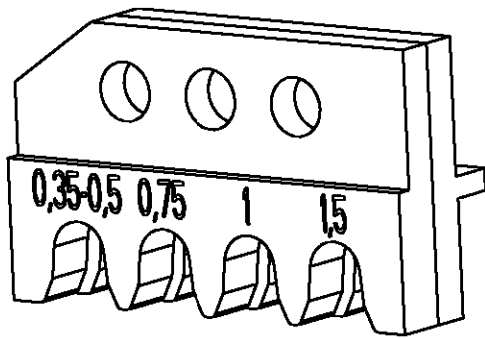

539773-2	1	2-539787-1	locator ass.	Positioniereinheit	A
	1	1-519151-3	screw M4x25	Schraube M4x25	A
	1	0-519151-9	screw M4x10	Schraube M4x10	A
	1	0-519024-2	hex nut M4	Mutter M4 DIN 985	A
	QTY Stck	PN	Description	Benennung	REV

RELEASED FOR PUBLICATION

THIS DRAWING IS UNPUBLISHED.

COPYRIGHT 19 BY TYCO ELECTRONICS CORPORATION. ALL RIGHTS RESERVED.

DIMENSIONS: mm-DIN 7168-m	DWN M. Weberndoerfer	30NOV99	MATERIAL	-	FINISH	-
	CHK U. Reuter	30NOV99	tyco Electronics AMP GmbH D - 64625 Bensheim			
TOLERANCES UNLESS OTHERWISE SPECIFIED:	APVD	-				
0 PLC ±	PRODUCT SPEC	-	SIZE			CAGE CODE
1 PLC ±	APPLICATION SPEC	-	DRAWING NO			RESTRICTED TO
2 PLC ±	WEIGHT	-	A 4	00779	©=539773-2	-
3 PLC ±	CUSTOMER DRAWING		SCALE	2:1	SHEET	1 OF 1
4 PLC ±					REV	A1
ANGLES ±						