

# LTM170E4 Information

Date : Aug. 25, 2000

Customer :

Prepared By Ji Hoon Kim

Checked By Yoo Dong Jo

**LCD Application Engineering Group**  
**AMLCD Division**

## 1. Changing Items

Item		LT170E2	LTM170E4	Note
Mounting Method		Front mounting	Front/Side mounting	*Compact & Slim *For compatibility, mounting bracket should be attached to E4 model. -> Refer to the figure 2.3
Out-Dim.	Module size (mm; H*V*D)	404x 322x 25(Max)	383.5x 306x 22.8(Max)	
	User hole	Hor.	394.0± 0.3	
		Ver. (Left/Right)	310.2/215.0± 0.3	
Bezel opening (mm; H*V)		342.0*274.4	341.52*273.936	*System housing should be designed to avoid the interference -> Refer to the figure 2.1 & 2.2
Connector	I/F Connector	JAE FI-WE31P-HF ( 31 Pin )	JAE FI-X30S-HF ( 30 Pin )	E2:TMDS, E4:LVDS(2 CH)
	Location	The connector of the E4 is located somewhat to the right lower side than E2.		->Refer to the figure 2.3
	B/L Connector	JST BHR -04VS - 1 ( 4Pin X 1 )	JST BHSR - 02VS - 1 ( 2Pin X 2 )	*Inverter should be changed.

## 1.1 Module Size

- ✓ More **Compact size** : 404 x 322 x 25(Max) => 383.5x 306x 22.8(Max)
- ✓ Mechanical compatibility with LT170E2 model : **additional bracket** is needed.

## 1.2 Optical Characteristics

- ✓ Color coordinate is approached near to **Black-body Temp.**  
0.305, 0.342 => 0.318, 0.339
- ✓ Color Gamut is improved : 50% => **60%**
- ✓ Brightness is improved : 170nits (typ.) => **200nits** (typ.)
- ✓ Response Time : 70ms (typ.) => **35ms** (typ.)
- ▶ **More suitable for multi-media application.**

## 1.3 Interface

- ✓ Changed from TMDS to **LVDS.(2 Channel)**  
.LVDS Rx is merged into Timing controller IC.
- ✓ Input connector : 31pin => **30pin**

## 1.4 Back-light Unit

- ✓ Lamp connector : 4pin x 1ea => **2pin x 2ea**
- ✓ Possible to insert feed-back circuit in design of inverter.

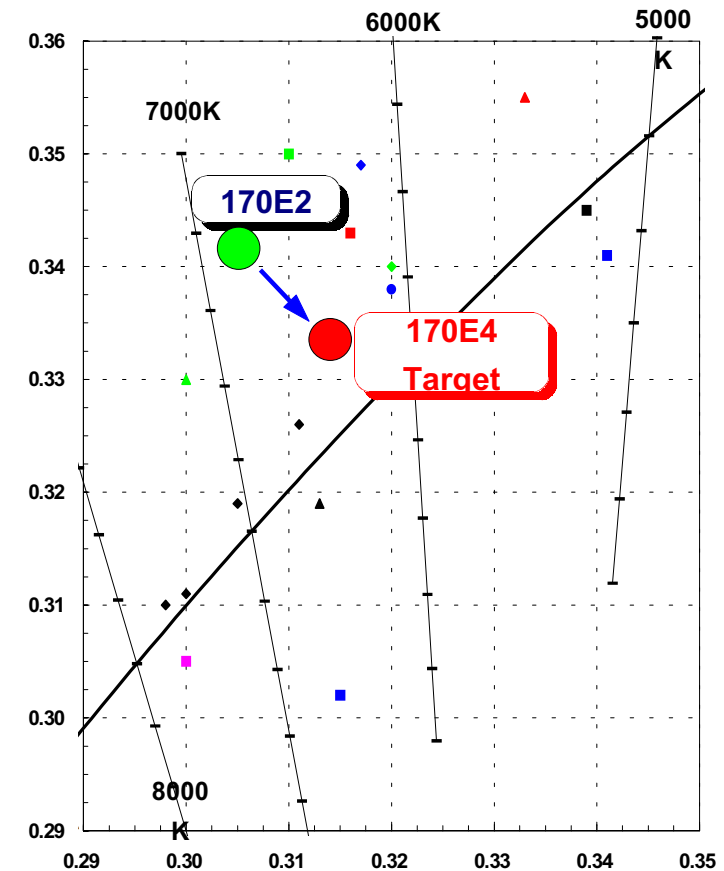

## 2. Mechanical Change

### 2.1 Bezel Opening

- Active area is same as E2, but bezel opening size is reduced.
- Therefore, Horizontal and vertical width of B/M (margin between top-chassis and active area) is reduced from 2.04mm to 1.8mm.  Refer to the Figure 2-1

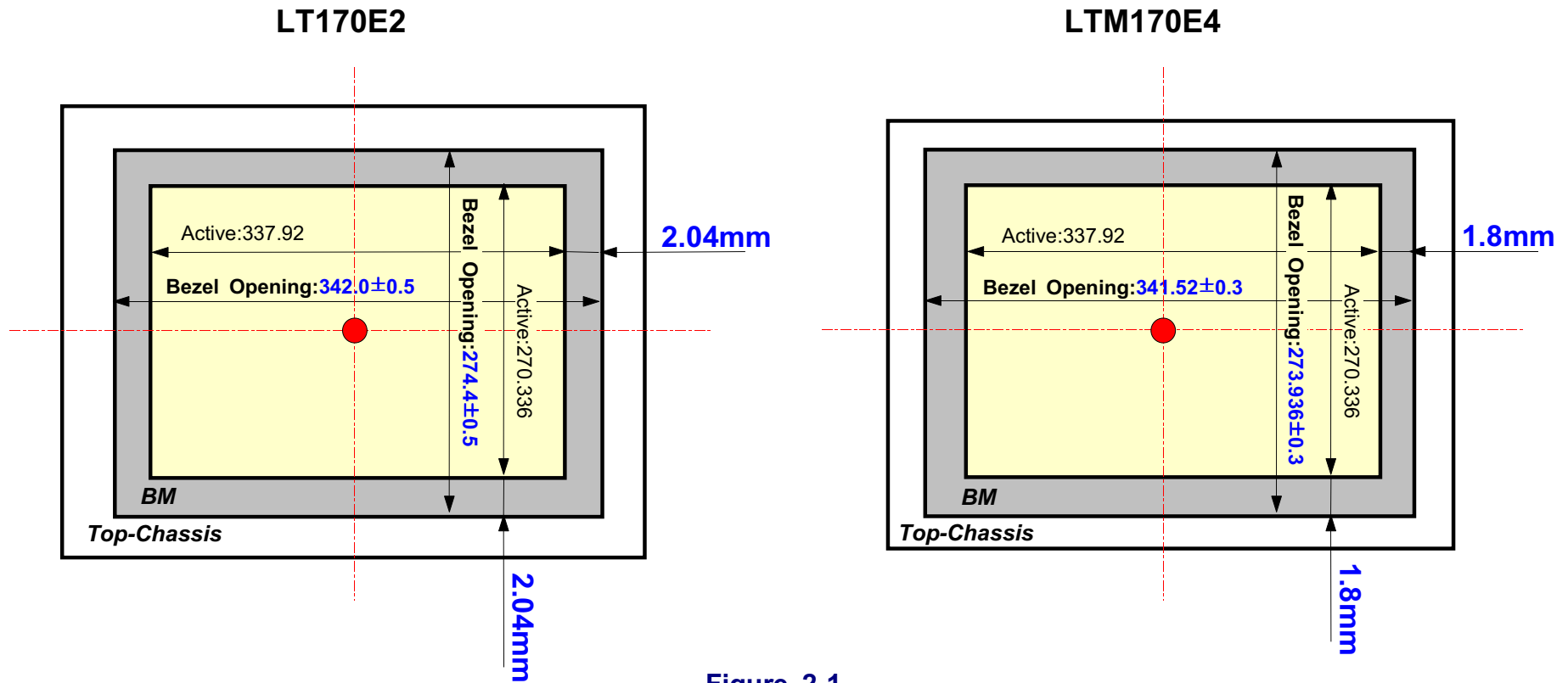



Figure 2-1

- System housing should be designed to avoid the interference.
- If you want adopt E4 model in your current system designed for E2, you should check the point as shown below.
- **Reduction may cause interference between system housing-front and top chassis of the panel.**  
 Refer to the Figure 2-2

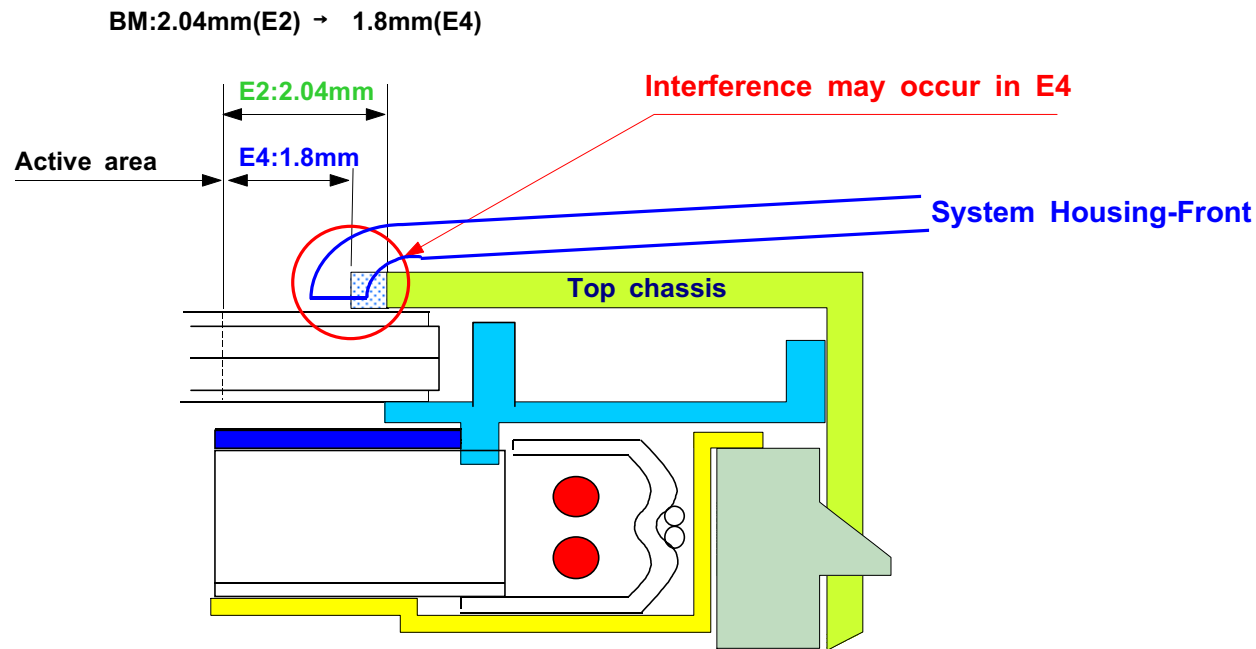



Figure 2-2

## 2.2 Location of User Hole

- Because Locations of user holes are not same as E2, mounting brackets should be attached to the 170E4 model for compatibility.  Refer to the Figure 2-3

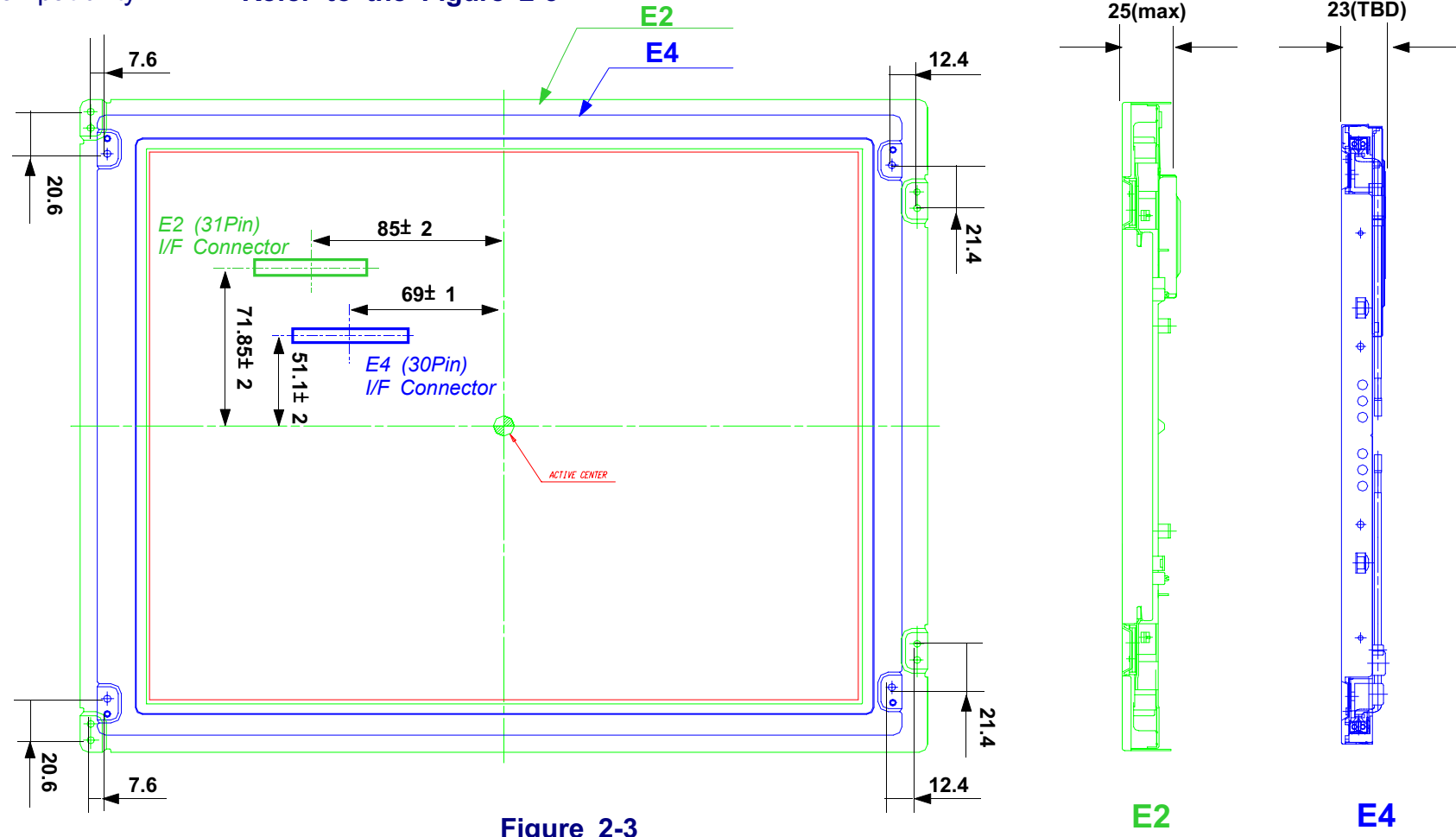
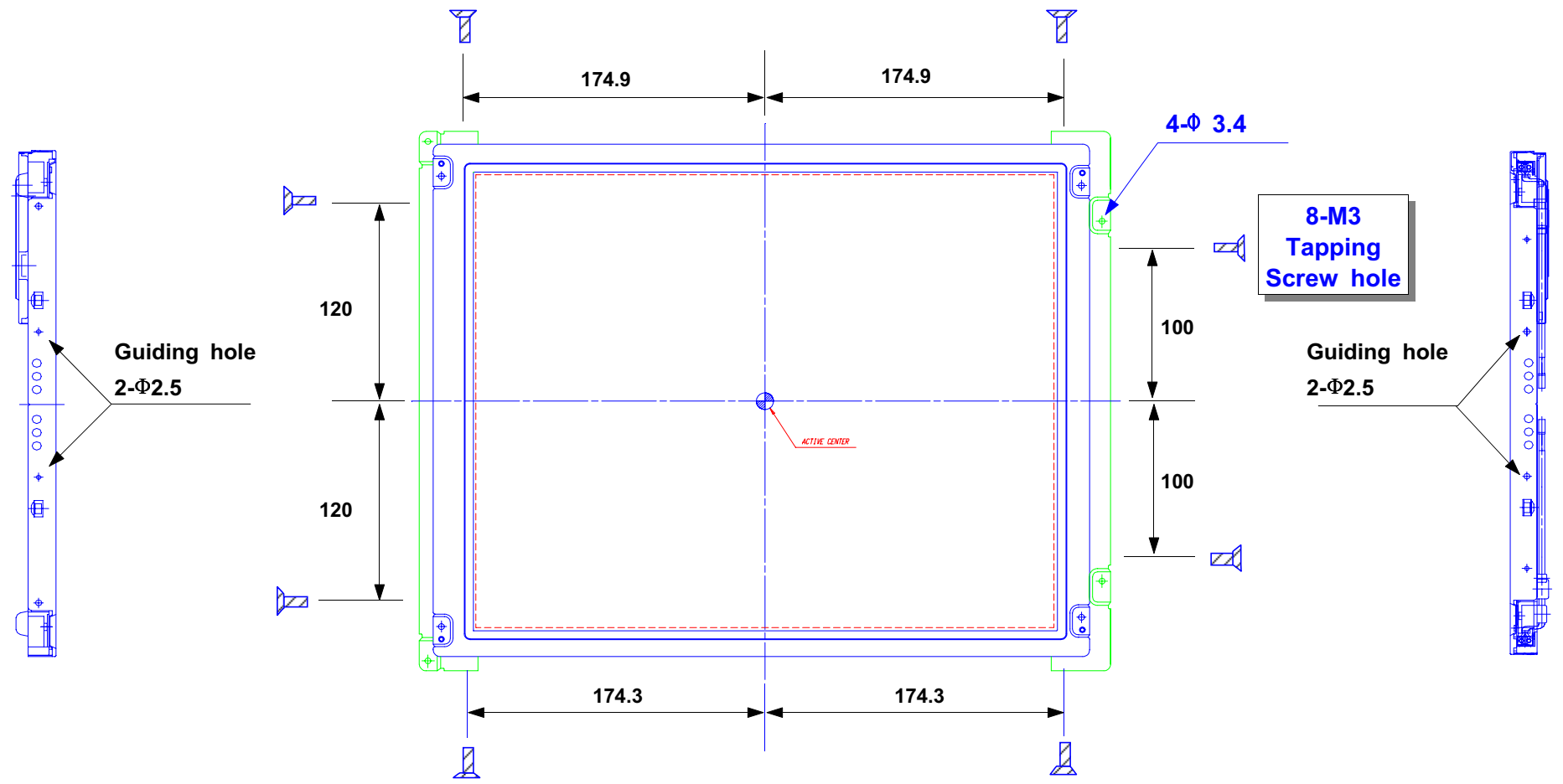

Figure 2-3

- You can fix the brackets to the module using screw holes and guiding holes.

☞ Refer to the Figure 2-4



\* For more detail informations, Please Refer to the Outline Dimensions

## 2.3 Mounting height

- The height from panel surface to the top surface of the chassis is more high than E2.
- But the height from bottom of the mounting tab to Panel surface is same.
- So you can easily design without height adjustment
  - ☞ **Height of mounting bracket's holes should be same as panel's.**

## 2.4 Location of Interface connector

- The connector of the E4 is located somewhat to the right lower side than E2. ☞ **Refer to the Figure 2-3**



### 3. Interface

#### 3.1 LVDS I/F Block Diagram

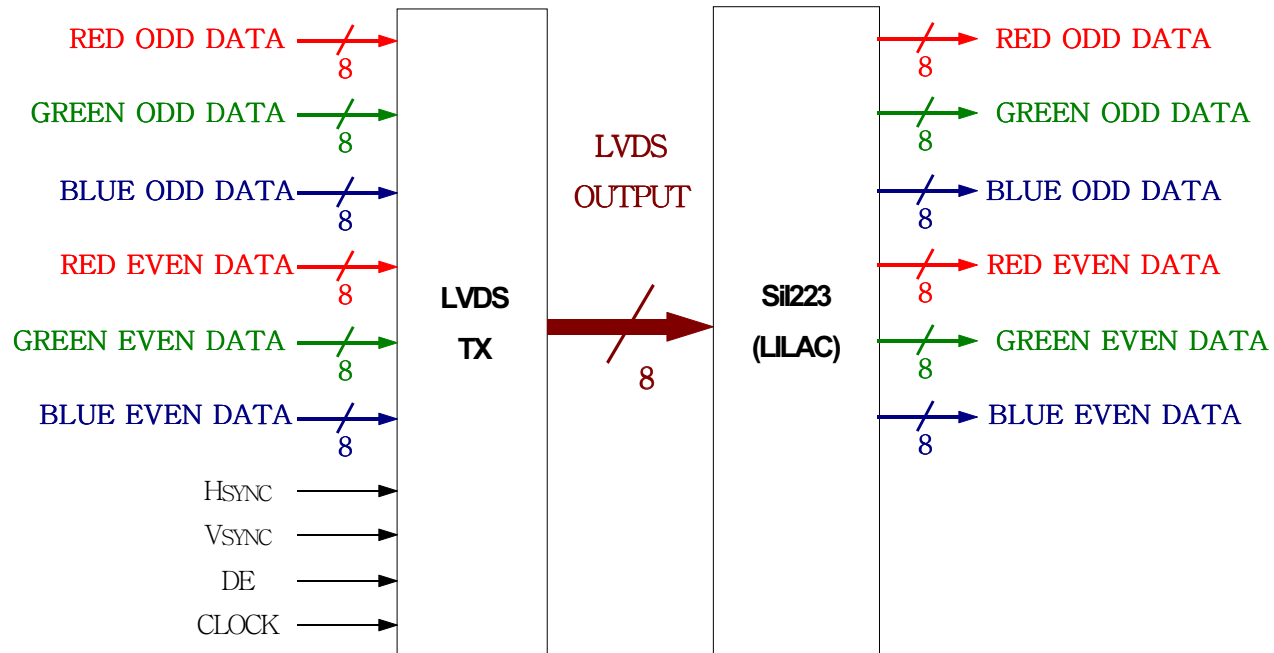

Note : There is difference between N/S spec & SiI223 spec(Silicon Image).  
 In N/S and Samsung TFT-LCD spec, Odd(Even) data is First(Second) pixel data.  
 But in SiI223 spec, Odd(Even) data is represented as Second(First) pixel data.  
 So you should be careful to interpret all data.



### 3.2 Input Terminal Pin Assignment

- Input Signal & Power ( Connector : JAE FI-X30S-HF )  
( Matching Socket : JAE FI-X30H )

O = " First Pixel Data "

E = " Second Pixel Data "

Pin #	Symbol	Function	Polarity	Output Pin # (Transmitter)	Pin #	Symbol	Function	Polarity	Output Pin # (Transmitter)
1	<b>GND</b>	Power Ground	-	Refer to Table	21	RxEC-	Low voltage swing	Negative	Refer to Table
2	RxO0-	First Pixel Data	Negative		22	RxEC+	differential input even clock	Positive	
3	RxO0+		Positive		23	RxE3-	Second Pixel Data	Negative	
4	RxO1-		Negative		24	RxE3+		Positive	
5	RxO1+		Positive		25	<b>GND</b>	Power Ground	-	
6	RxO2-		Negative		26	NC	-	-	
7	RxO2+		Positive		27	DE	Signal	-	
8	<b>GND</b>		Power Ground		-	28	NC	-	
9	RxOC-	Low voltage swing	Negative		29	POWER (5V)	Power	-	
10	RxOC+	differential input odd clock	Positive		30	POWER (5V)	Power	-	
11	RxO3-	First Pixel Data	Negative		31	POWER (5V)	Power	-	
12	RxO3+		Positive		32	<b>GND</b>	Power Ground	-	
13	RxE0-	Second Pixel Data	Negative						
14	RxE0+		Positive						
15	<b>GND</b>	Power Ground	-						
16	RxE1-	Second Pixel Data	Negative						
17	RxE1+		Positive						
18	<b>GND</b>	Power Ground	-						
19	RxE2-	Second Pixel Data	Negative						
20	RxE2+		Positive						

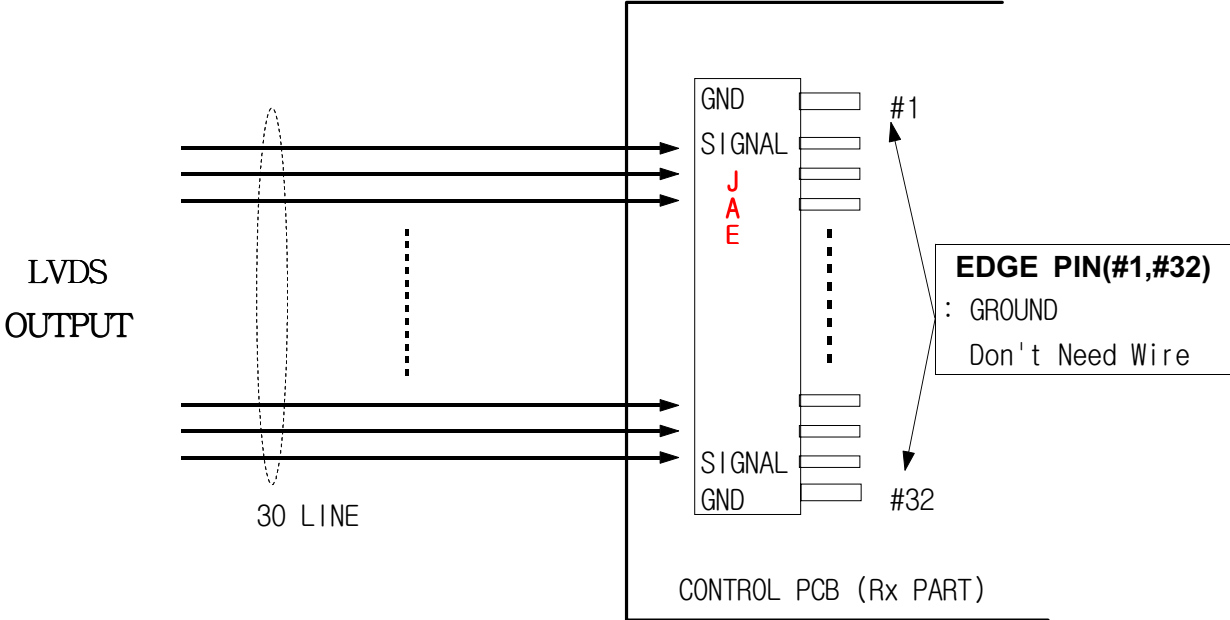

### 3.3 JAE FI-X30S-HF (30 PIN) PIN MAP

0 = " First Pixel Data " / E = " Second Pixel Data "

VGA-TFT Data		DS90C383	DS90C385	DS90C387
LSB/MSB	Color Bit	PIN NAME (PIN#)	PIN NAME (PIN#)	PIN NAME(PIN#)
<b>LSB</b>	R00 / RE0	1st TXIN0 (51) / 2nd TXIN0 (51)		R10 (10) / R20 (84)
	R01 / RE1	1st TXIN1 (52) / 2nd TXIN1 (52)		R11 (9) / R21 (81)
	R02 / RE2	1st TXIN2 (54) / 2nd TXIN2 (54)		R12 (8) / R22 (80)
	R03 / RE3	1st TXIN3 (55) / 2nd TXIN3 (55)		R13 (7) / R23 (79)
	R04 / RE4	1st TXIN4 (56) / 2nd TXIN4 (56)		R14 (6) / R24 (78)
	R05 / RE5	1st TXIN6 (3) / 2nd TXIN6 (3)		R15 (5) / R25 (77)
	R06 / RE6	1st TXIN27 (50) / 2nd TXIN27 (50)		R16 (4) / R26 (76)
<b>MSB</b>	R07 / RE7	1st TXIN5 (2) / 2nd TXIN5 (2)		R17 (3) / R27 (75)
<b>LSB</b>	G00 / GE0	1st TXIN7 (4) / 2nd TXIN7 (4)		G10 (2) / G20 (74)
	G01 / GE1	1st TXIN8 (6) / 2nd TXIN8 (6)		G11 (1) / G21 (73)
	G02 / GE2	1st TXIN9 (7) / 2nd TXIN9 (7)		G12 (100) / G22 (72)
	G03 / GE3	1st TXIN12 (11) / 2nd TXIN12 (11)		G13 (99) / G23 (71)
	G04 / GE4	1st TXIN13 (12) / 2nd TXIN13 (12)		G14 (96) / G24 (70)
	G05 / GE5	1st TXIN14 (14) / 2nd TXIN14 (14)		G15 (95) / G25 (69)
	G06 / GE6	1st TXIN10 (8) / 2nd TXIN10 (8)		G16 (94) / G26 (66)
<b>MSB</b>	G07 / GE7	1st TXIN11 (10) / 2nd TXIN11 (10)		G17 (93) / G27 (65)
<b>LSB</b>	B00 / BE0	1st TXIN15 (15) / 2nd TXIN15 (15)		B10 (92) / B20 (64)
	B01 / BE1	1st TXIN18 (19) / 2nd TXIN18 (19)		B11 (91) / B21 (63)
	B02 / BE2	1st TXIN19 (20) / 2nd TXIN19 (20)		B12 (90) / B22 (62)
	B03 / BE3	1st TXIN20 (22) / 2nd TXIN20 (22)		B13 (89) / B23 (61)
	B04 / BE4	1st TXIN21 (23) / 2nd TXIN21 (23)		B14 (88) / B24 (60)
	B05 / BE5	1st TXIN22 (24) / 2nd TXIN22 (24)		B15 (87) / B25 (59)
	B06 / BE6	1st TXIN16 (16) / 2nd TXIN16 (16)		B16 (86) / B26 (58)
<b>MSB</b>	B07 / BE7	1st TXIN17 (18) / 2nd TXIN17 (18)		B17 (85) / B27 (57)

☞ DS90C387 : BAL pin(pin#24) → "LOW" Fix,  
DUAL pin(pin# 23) → "HIGH" Fix.

### 3.4 Interface Timing

Signal	Item	Symbol	Min.	Typ.	Max.	Unit	Note
Clock	Frequency	1/TC	40	-	54	MHz	
	Hgh Time	TCH	4	-	-	nsec	
	Low Time	TCL	4	-	-	nsec	
Data	Setup Time	TDS	4	-	-	nsec	
	Hold Time	TDH	4	-	-	nsec	
Data Enable	Setup Time	TES	4	-	-	nsec	(1)
Frame Frequency	Cycle	TV	-	16.7	16.7	msec	
			1032	1066	1066	lines	
Vertical Active Disply Term	Display Period	TVD	1024	1024	1024	lines	
	Verticle Blank Period	TVB	8	-	-	lines	
One Line Scanning Time	Cycle	TH	672	-	844	clocks	
Horizontal Active Display Term	Display Period	THD	640	640	640	clocks	

Note (1) When LTM170E4-L01 model is operated by DE only mode, Hsync and Vsync input signals should be fixed to low for stable operation. Otherwise, the module could operate abnormally.



### 3.5 LVDS OUTPUT TIMING

#### 1) DS90C383, DS90C385 LVDS OUTPUT TIMING IN TRANSMISSION

O = " First Pixel Data "  
 E = " Second Pixel Data "

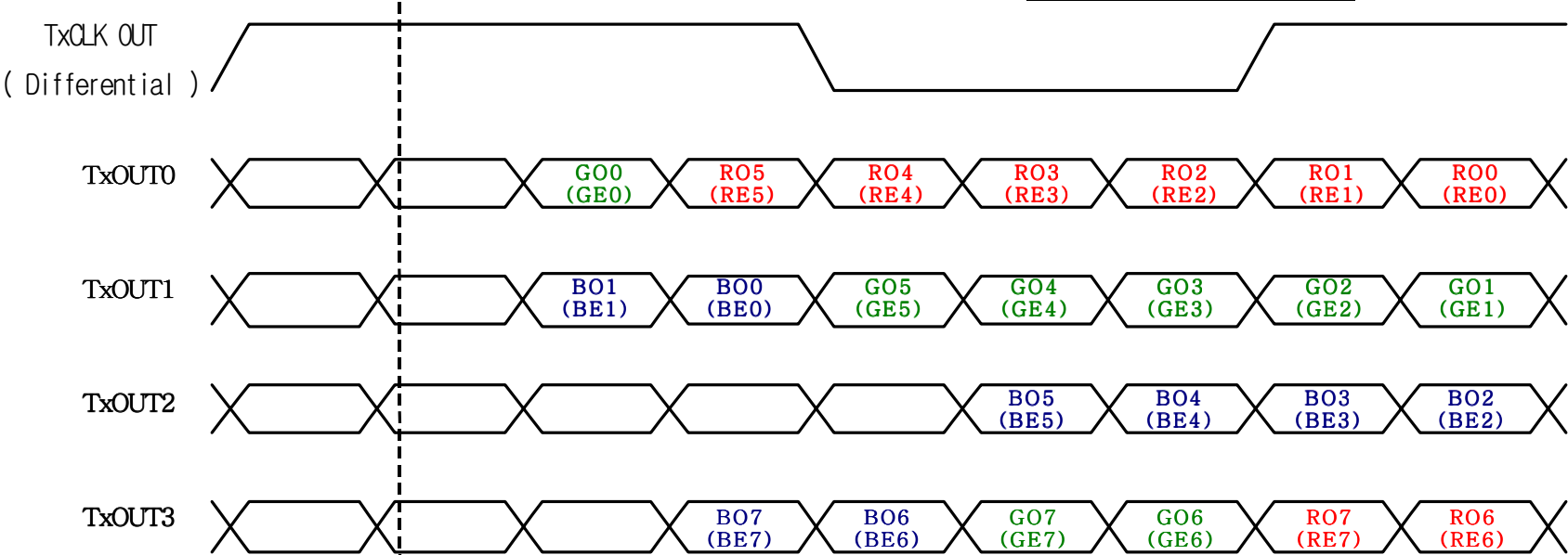

☞ GO0 : LSB Green data of 1st LVDS Tx Output  
 GE0 : LSB Green data of 2nd LVDS Tx Output



### 3.5 LVDS OUTPUT TIMING

#### 2) DS90C387 LVDS OUTPUT TIMING IN TRANSMISSION (BAL= LOW)

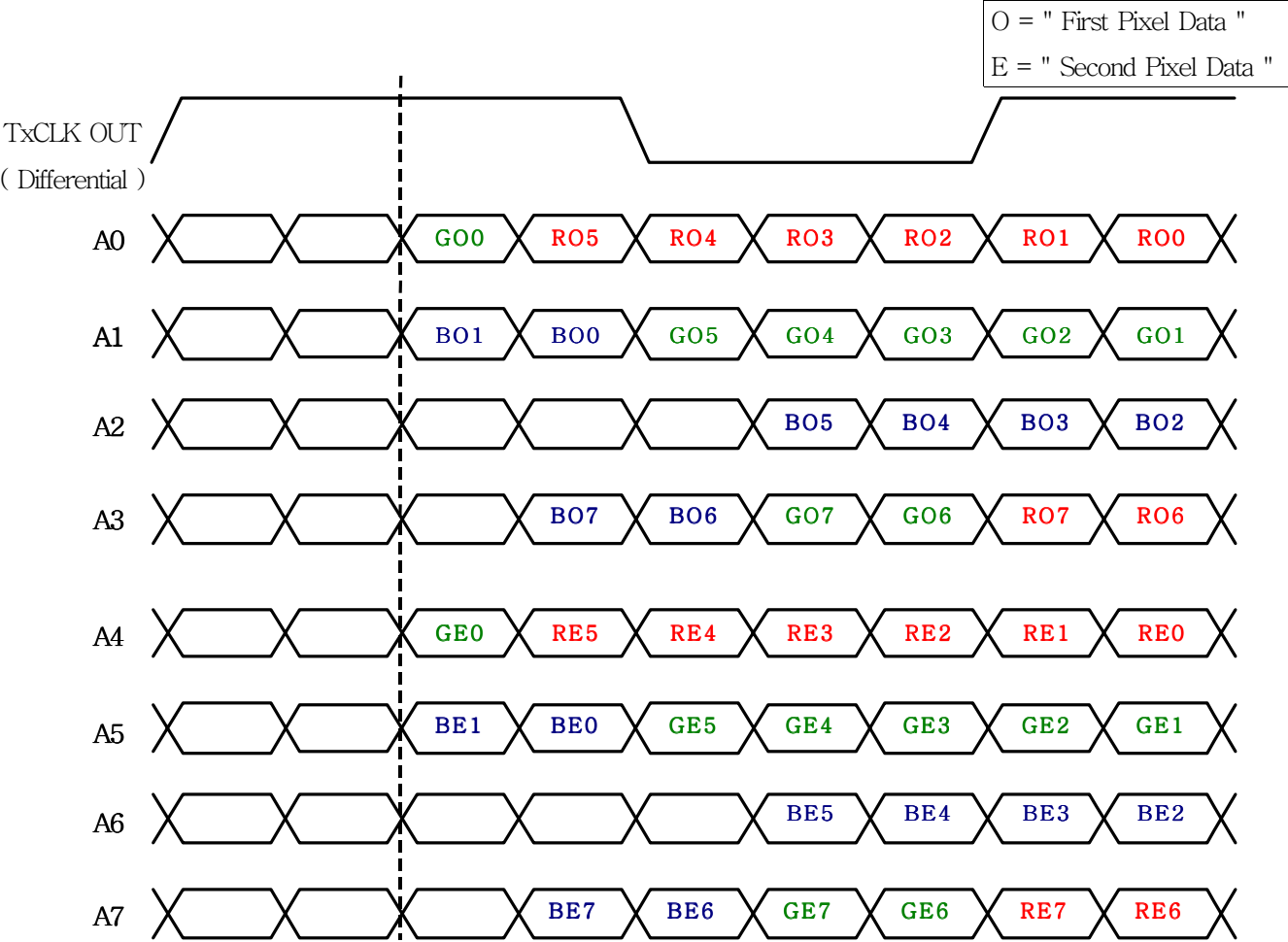

## 4. Back-Light

### 4.1 Back-Light Unit Connector

Pin No.	Input [Ch1][Ch2], [Ch3][Ch4]	Color	Function
1	Hot	PINK	High Voltage
2	Cold	WHITE	Ground
3	Hot	BLUE	High Voltage
4	Cold	BLACK	Ground
Connector Part No.	JST BHSR - 02VS - 1		
Matching Connector	SM02B - BHSS -1-TB		

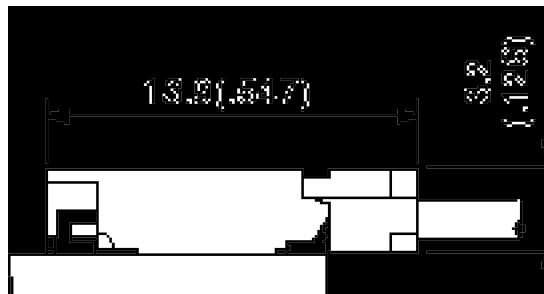
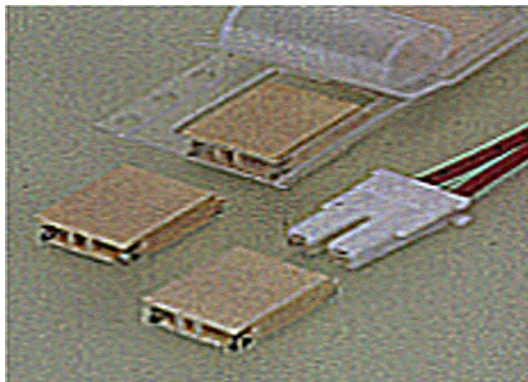



## 4.2 Block Diagram

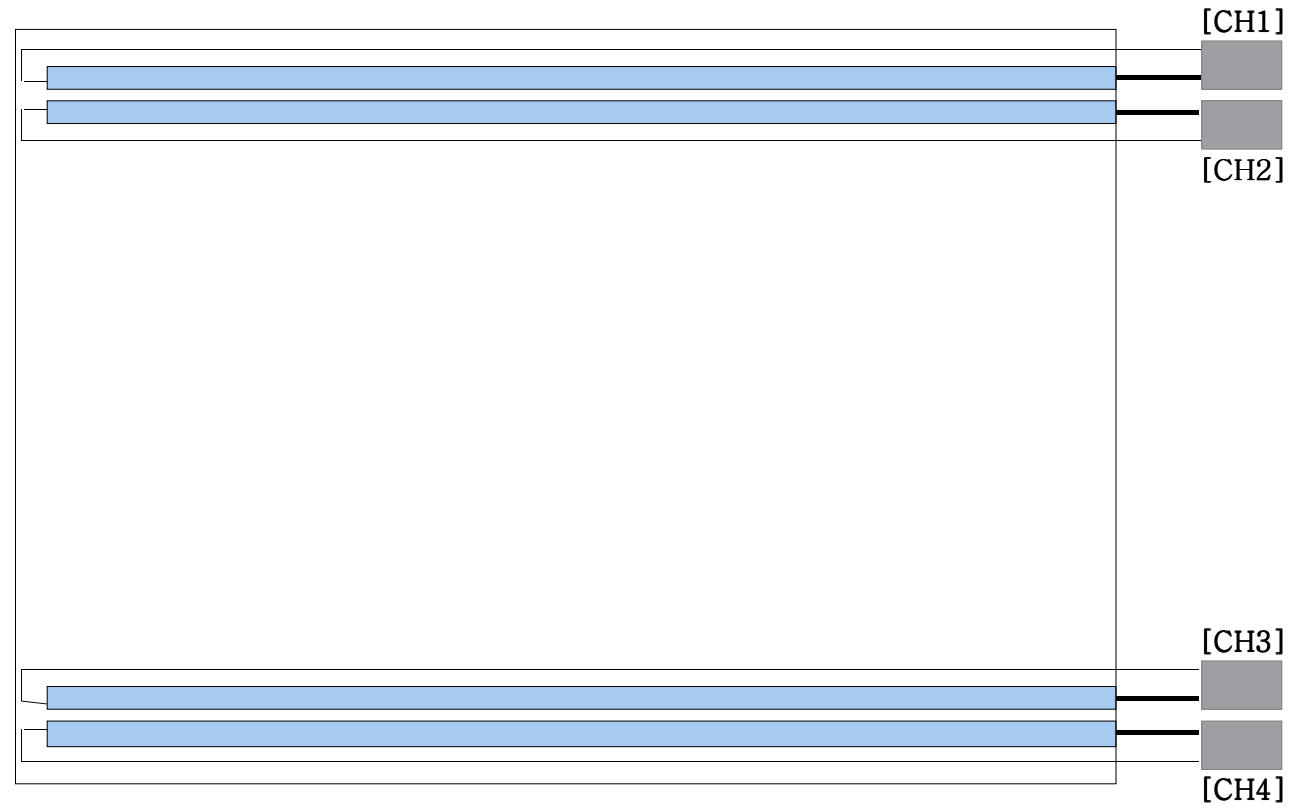

# ◆ Out-dimension of LTM170E4-L01

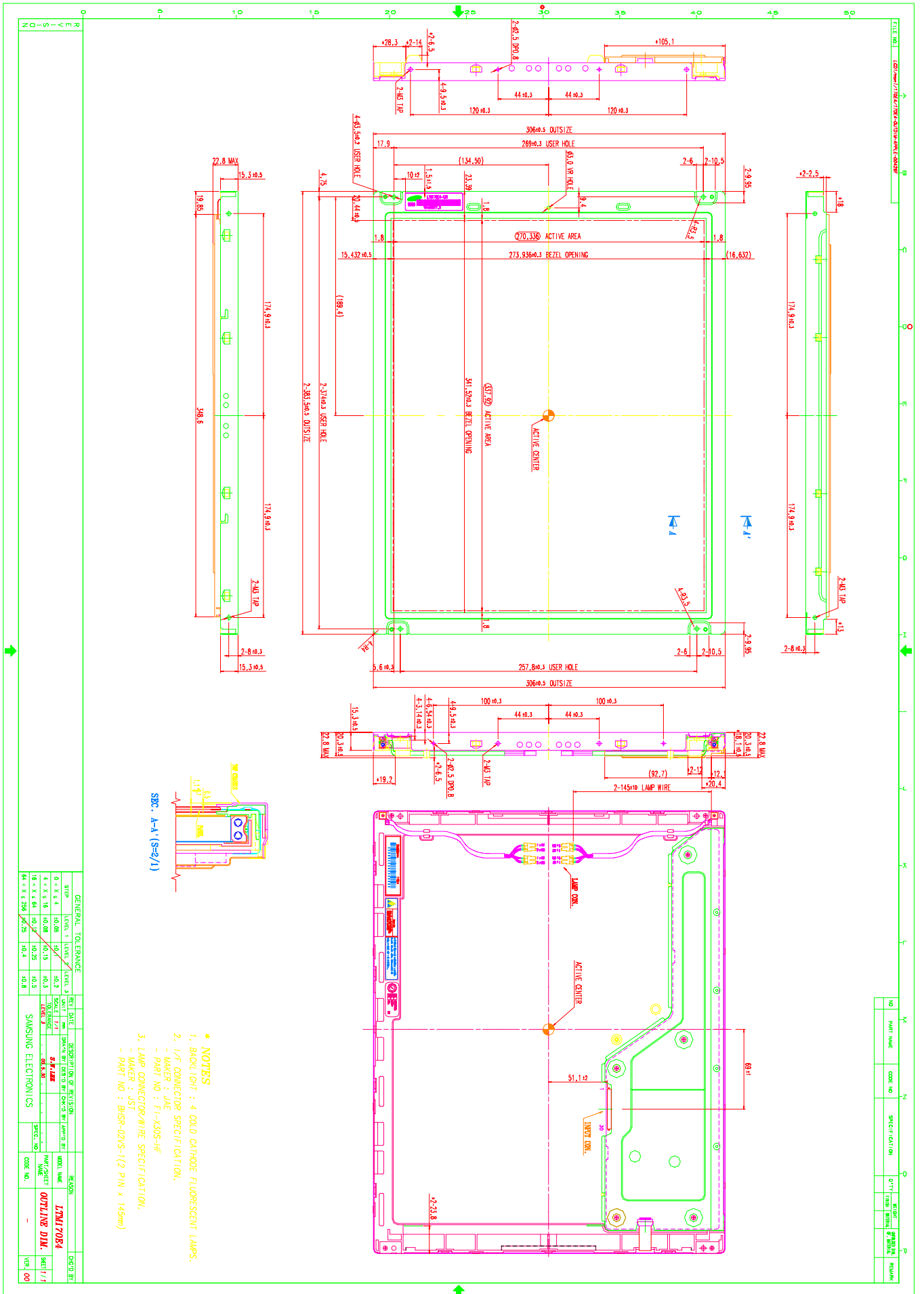

# Bracket information for LTM170E4-L01

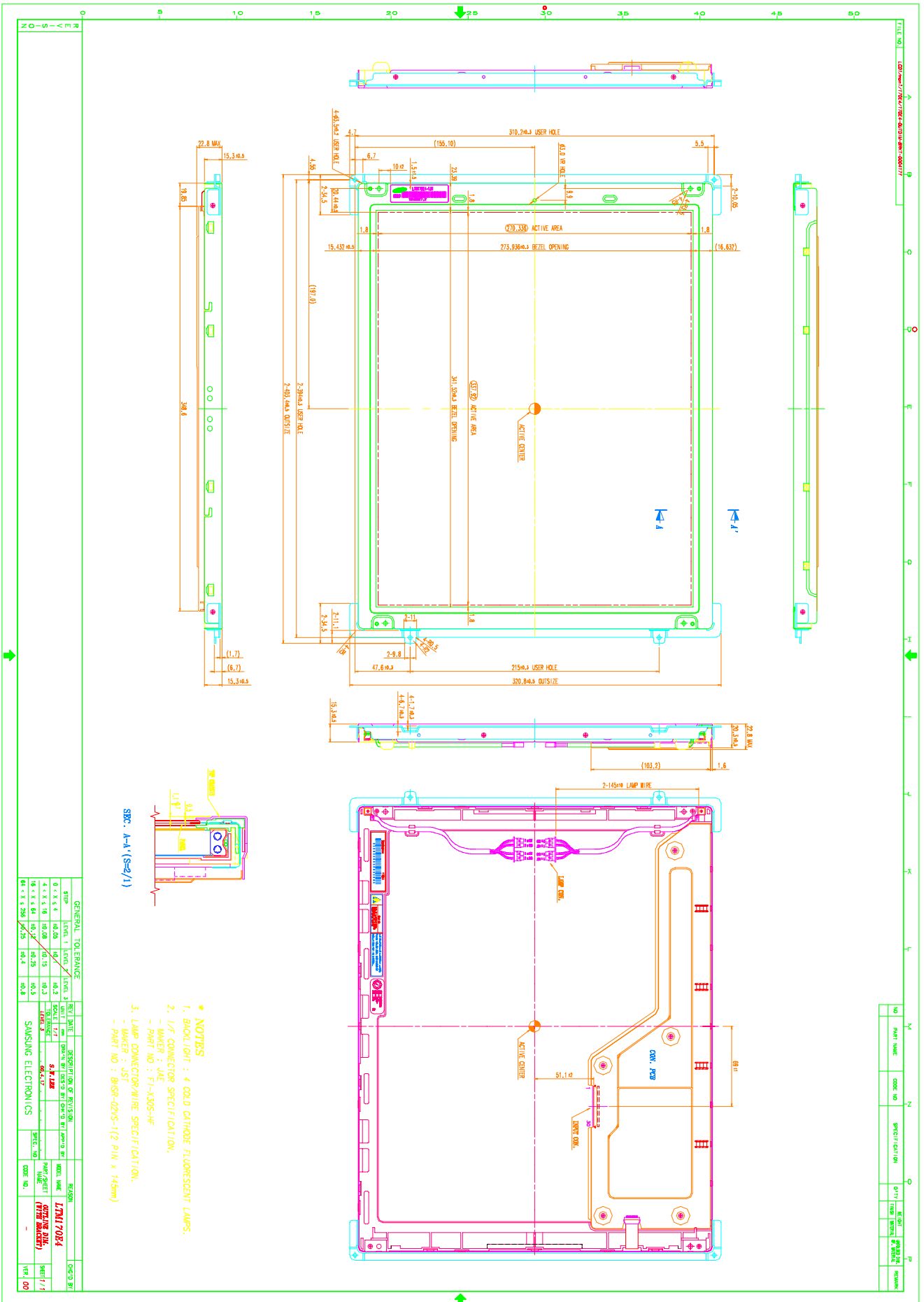

SEC. A-A (See/1)

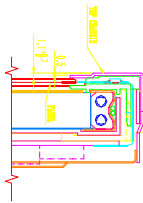

- \* NOTES**
1. BACKLIGHT : 4 COLD CATHODE FLUORESCENT LAMPS.
  2. I/F CONNECTOR SPECIFICATION.  
- MAKER : JAE  
- PART NO : EI-X305-HF
  3. LAMP CONNECTOR/WIRE SPECIFICATION.  
- PART NO : BMSF-02/S-(72 PIN x 145µm)

GENERAL TOLERANCE				SPEC. DATE				OPERATION OF REVISION				DRAWING			
STEP	LEVEL 1	LEVEL 2	LEVEL 3	DATE	NO.	DESCRIPTION	DATE	NO.	DESCRIPTION	DATE	NO.	DESCRIPTION	DATE	NO.	DESCRIPTION
0, 2, 3, 4	±0.05	±0.1	±0.2												
1	±0.15	±0.25	±0.3												
10, 2, 3, 4, 6, 8, 10, 12	±0.2	±0.3	±0.4												
14, 2, 3, 20	±0.4	±0.5	±0.6												

SAMSUNG ELECTRONICS				DRAWING			
DATE	NO.	DESCRIPTION	DATE	NO.	DESCRIPTION	DATE	NO.

DRAWING	
DATE	NO.
2011.07.04	01

NO.	DATE	NO.	DESCRIPTION	DATE	NO.	DESCRIPTION

NO	PART NAME	CODE NO	SPECIFICATION	QTY	WEIGHT	REMARK
1	BROCH-COMMUTABLE(I)	L67-00754	SEC. 11.2, I/1/2/4	1 EA		

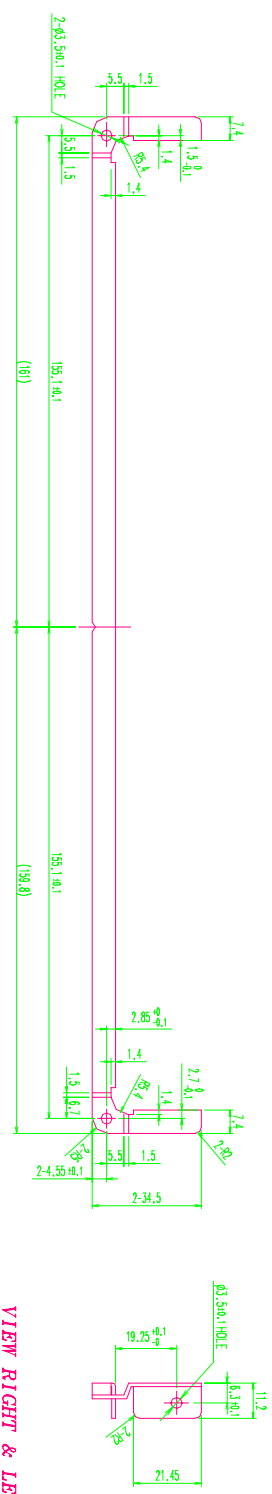

VIEW RIGHT & LEFT

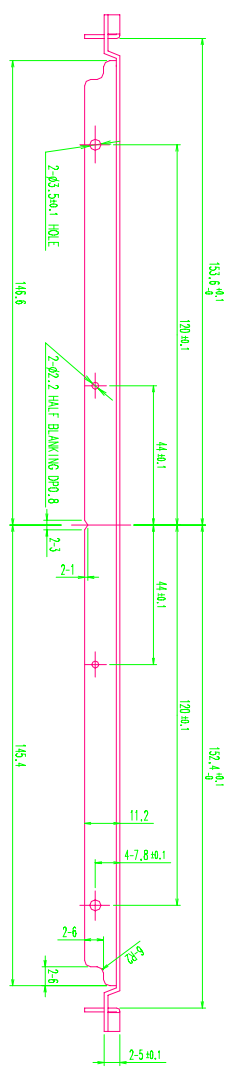

- \* NOTES**
1. PART TO FREE FROM RUST AND SCRATCH
  2. MATERIAL : SECC T1.2
  3. BURR HEIGHT : 0.08mm MAX
  4. UNLESS SPECIFIED, ALL CORNERS AND EDGES ARE R0.3

GENERAL TOLERANCE		REV	DATE	DESCRIPTION OF REVISION	MODEL NAME	CHG'D BY
STEP	LEVEL	LEVEL 2	LEVEL 3	UNIT	SCALE	
0 < X ≤ 4	±0.05	±0.1	±0.2	mm	5:1 L&E	L7M170E4
4 < X ≤ 16	±0.08	±0.15	±0.3			BROCH-COMMUTABLE(I)
16 < X ≤ 64	±0.12	±0.25	±0.5			SPEE. NO
64 < X ≤ 256	±0.25	±0.4	±0.8			CODE NO.
		SAMSUNG ELECTRONICS		SP		L67-003754
						VER. 00



# ◆ Out-dimension of LT170E2-131

