

TOSHIBA CCD IMAGE SENSOR CCD (Charge Coupled Device)

TCD2901D

The TCD2901D is a high sensitive and low dark current 10550 elements×3 line CCD color image sensor which includes CCD drive circuit and clamp circuit. The sensor is designed for scanner. The device contains a row of 10550 elements×3 line photodiodes which provide a 48 lines / mm (1200DPI) across a A4 size paper. The device is operated by 5 V pulse, and 12 V power supply.

FEATURES

- Number of Image Sensing Elements : 10550 elements×3 line
- Image Sensing Element Size : 4μm by 4μm on 4μm centers
- Photo Sensing Region : High sensitive and low dark current PN photodiode
- Distance Between Photodiode Array : 48μm (12 lines)
- Clock : 2 phase (5 V)
- Power Supply : 12 V Power Supply Voltage
- Internal Circuit : Clamp circuit
- Package : 22 pin CERDIP package
- Color Filter : Red, Green, Blue

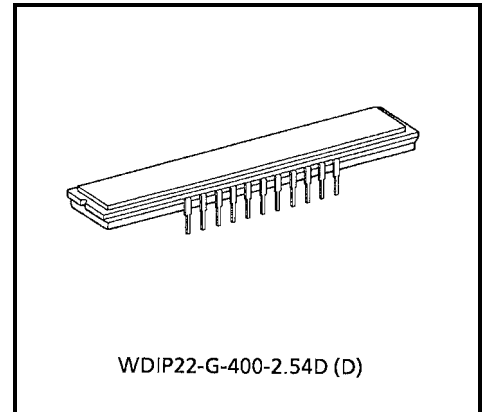

Weight: 5.2g (Typ.)

MAXIMUM RATINGS (Note 1)

CHARACTERISTIC	SYMBOL	RATING	UNIT
Clock Pulse Voltage	$V_{\phi A}$	-0.3~8	V
Shift Pulse Voltage	V_{SH}		
Reset Pulse Voltage	V_{RS}		
Clamp Pulse Voltage	V_{CP}		
Power Supply Voltage	V_{OD}	-0.3~15	V
Operating Temperature	T_{opr}	0~60	°C
Storage Temperature	T_{stg}	-25~85	°C

Note 1: All voltage are with respect to SS terminals (Ground).

PIN CONNECTION

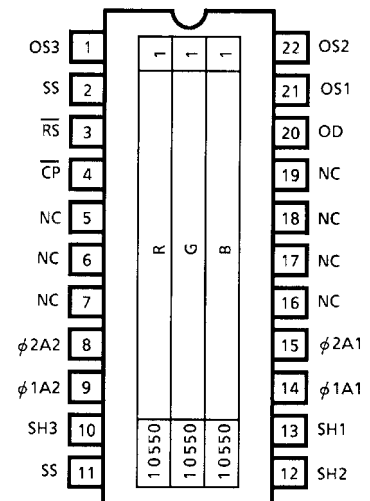

(TOP VIEW)

CIRCUIT DIAGRAM

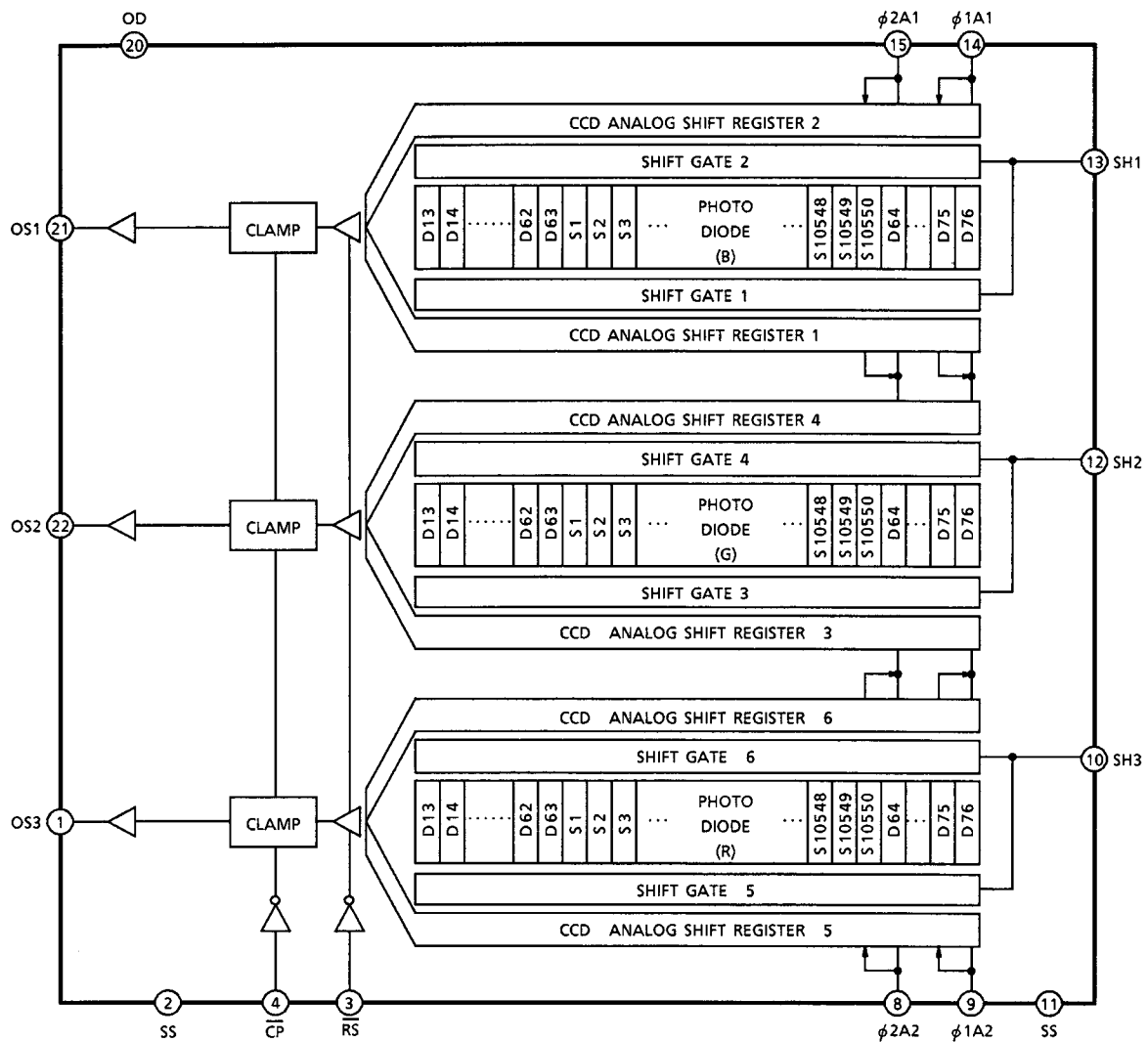

PIN NAMES

PIN No.	SYMBOL	NAME	PIN No.	SYMBOL	NAME
1	OS3	Signal Output 3 (Red)	22	OS2	Signal Output 2 (Green)
2	SS	Ground	21	OS1	Signal Output 1 (Blue)
3	RS	Reset Gate	20	OD	Power
4	CP	Clamp Gate	19	NC	Non Connection
5	NC	Non Connection	18	NC	Non Connection
6	NC	Non Connection	17	NC	Non Connection
7	NC	Non Connection	16	NC	Non Connection
8	$\phi 2A2$	Clock 2 (Phase 2)	15	$\phi 2A1$	Clock 1 (phase 2)
9	$\phi 1A2$	Clock 2 (Phase 1)	14	$\phi 1A1$	Clock 1 (phase 1)
10	SH3	Shift Gate 3	13	SH1	Shift Gate 1
11	SS	Ground	12	SH2	Shift Gate 2

OPTICAL / ELECTRICAL CHARACTERISTICS

(Ta = 25°C, V_{OD} = 12 V, V_φ = V_{SH} = V_{RS} = V_{CP} = 5 V (PULSE), f_φ = 0.5MHz, f_{RS} = 1 MHz, t_{INT} = 11 ms, LIGHT SOURCE = A LIGHT SOURCE+CM500S FILTER (t = 1 mm), LOAD RESISTANCE = 100 kΩ)

CHARACTERISTIC		SYMBOL	MIN	TYP.	MAX	UNIT	NOTE
Sensitivity	Red	R _(R)	1.7	2.5	3.3	V / (lx·s)	(Note 2)
	Green	R _(G)	1.6	2.4	3.2		
	Blue	R _(B)	0.9	1.4	1.9		
Photo Response Non Uniformity		PRNU (1)	—	15	20	%	(Note 3)
		PRNU (3)	—	3	12	mV	(Note 4)
Register Imbalance		RI	—	1	—	%	(Note 5)
Saturation Output Voltage		V _{SAT}	2.9	3.5	—	V	(Note 6)
Saturation Exposure		SE	0.91	1.46	—	lx·s	(Note 7)
Dark Signal Voltage		V _{DRK}	—	0.5	2.0	mV	(Note 8)
Dark Signal Non Uniformity		DSNU	—	2.0	7.0	mV	(Note 8)
DC Power Dissipation		P _D	—	260	450	mW	
Total Transfer Efficiency		TTE	92	98	—	%	
Output Impedance		Z _O	—	0.3	1.0	kΩ	
DC Compensation Output Voltage		V _{OS}	4.0	5.0	6.0	V	(Note 9)
Random Noise		N _{Dσ}	—	0.8	—	mV	(Note 10)
Reset Noise		V _{RSN}	—	0.3	1.0	V	(Note 9)
Masking Noise		V _{MS}	—	0.2	1.0	V	(Note 9)

Note 2: Sensitivity is defined for each color of signal outputs average when the photosensitive surface is applied with the light of uniform illumination and uniform color temperature.

Note 3: PRNU (1) is defined for each color on a single chip by the expressions below when the photosensitive surface is applied with the light of uniform illumination and uniform color temperature.

$$PRNU(1) = \frac{\Delta\bar{\chi}}{\bar{\chi}} \times 100(\%)$$

Where $\bar{\chi}$ is average of total signal output and $\Delta\bar{\chi}$ is the maximum deviation from $\bar{\chi}$. The amount of incident light is shown below.

$$\begin{aligned} \text{Red} &= 1/2 \cdot SE \\ \text{Green} &= 1/2 \cdot SE \\ \text{Blue} &= 1/4 \cdot SE \end{aligned}$$

Note 4: PRNU (3) is defined as maximum voltage with next pixels, where measured at 5% of SE (Typ.).

Note 5: Register imbalance is defined as follows.

$$RI = \frac{\sum_{n=1}^{10549} |\chi_n - \chi_{(n+1)}|}{10549 \cdot \bar{\chi}} * 100(\%)$$

Note 6: V_{SAT} is defined as minimum saturation output of all effective pixels.

Note 7: Definition of SE

$$SE = \frac{V_{SAT}}{R_G} (lx \cdot s)$$

Note 8: V_{DRK} is defined as average dark signal voltage of all effective pixels.

DSNU is defined as different voltage between V_{DRK} and V_{MDK} when V_{MDK} is maximum dark signal voltage.



Note 9: DC signal output voltage is defined as follows.

Reset Noise Voltage is defined as follows.

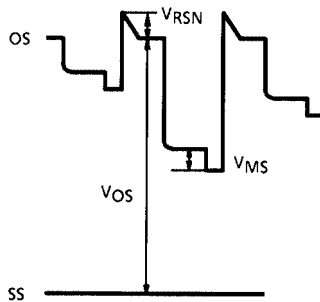

Note 10: Random noise is defined as the standard deviation (sigma) of the output level difference between two adjacent effective pixels under no illumination (i.e. dark conditions) calculated by the following procedure.

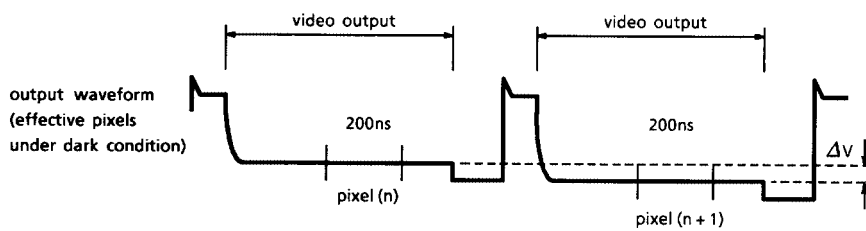

- 1) Two adjacent pixels (pixel n and n+1) in one reading are fixed as measurement points.
- 2) Each of the output level at video output periods averaged over 200ns period to get V (n) and V (n+1).
- 3) V (n+1) is subtracted from V (n) to get ΔV.

$$\Delta V = V(n) - V(n+1)$$

- 4) The standard deviation of ΔV is calculated after procedure 2) and 3) are repeated 30 times (30 readings).

$$\overline{\Delta V} = \frac{1}{30} \sum_{i=1}^{30} |\Delta V_i| \quad \sigma = \sqrt{\frac{1}{30} \sum_{i=1}^{30} (|\Delta V_i| - \overline{\Delta V})^2}$$

- 5) Procedure 2), 3) and 4) are repeated 10 times to get sigma value.
- 6) 10 sigma values are averaged.

$$\overline{\sigma} = \frac{1}{10} \sum_{j=1}^{10} \sigma_j$$

- 7) $\overline{\sigma}$ value calculated using the above procedure is observed $\sqrt{2}$ times larger than that measured relative to the ground level. So we specify random noise as follows.

$$ND\sigma = \frac{1}{\sqrt{2}} \overline{\sigma}$$

OPERATING CONDITION

CHARACTERISTIC		SYMBOL	MIN	TYP.	MAX	UNIT	NOTE
Clock Pulse Voltage	"H" Level	$V_{\phi A}$	4.75	5.0	5.5	V	
	"L" Level		0	—	0.3		
Shift Pulse Voltage	"H" Level	V_{SH}	$V_{\phi A} \text{"H"} - 0.5$	$V_{\phi A} \text{"H"}$	$V_{\phi A} \text{"H"}$	V	(Note 11)
	"L" Level		0	0	0.5		
Reset Pulse Voltage	"H" Level	$\overline{V_{RS}}$	4.5	5.0	5.5	V	
	"L" Level		0	0	0.5		
Clamp Pulse Voltage	"H" Level	$\overline{V_{CP}}$	4.5	5.0	5.5	V	
	"L" Level		0	0	0.5		
Power Supply Voltage		V_{OD}	11.4	12.0	13.0	V	

Note 11: $V_{\phi A}$ "H" means the high level voltage of $V_{\phi A}$ when SH pulse is high level.

CLOCK CHARACTERISTICS (Ta = 25°C)

CHARACTERISTIC	SYMBOL	MIN	TYP.	MAX	UNIT
Clock Pulse Frequency	$f_{\phi A}$	0.15	0.5	2.5	MHz
Reset Pulse Frequency	$\overline{f_{RS}}$	0.3	1.0	5.0	MHz
Clamp Pulse Frequency	$\overline{f_{CP}}$	0.3	1.0	5.0	MHz
Clock Capacitance (Note 12)	$C_{\phi A}$	—	350	450	pF
Shift Gate Capacitance	C_{SH}	—	50	100	pF
Reset Gate Capacitance	$\overline{C_{RS}}$	—	10	20	pF
Clamp Gate Capacitance	$\overline{C_{CP}}$	—	10	20	pF

Note 12: $V_{OD} = 12 \text{ V}$

TIMING CHART

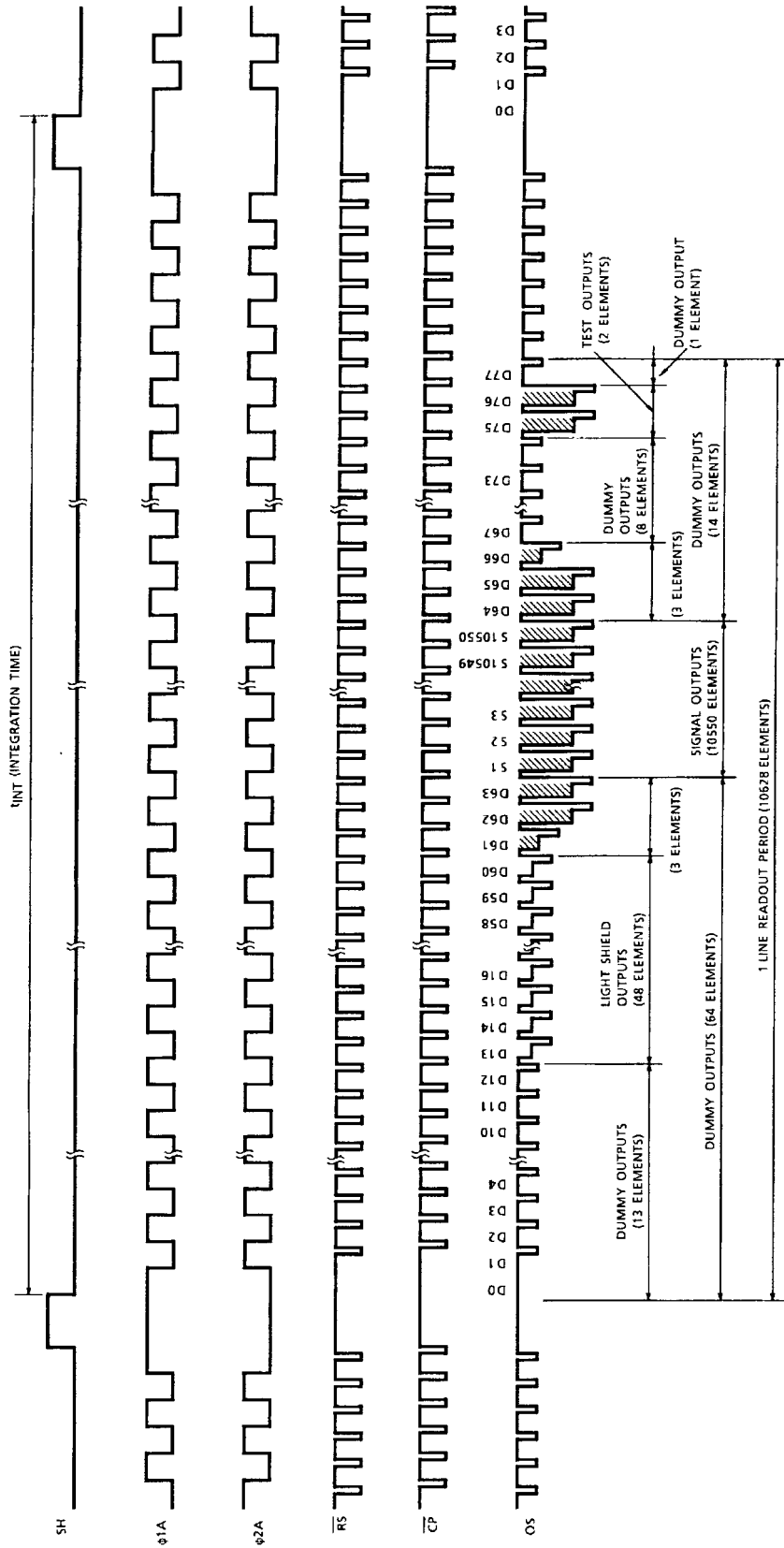

TIMING REQUIREMENTS

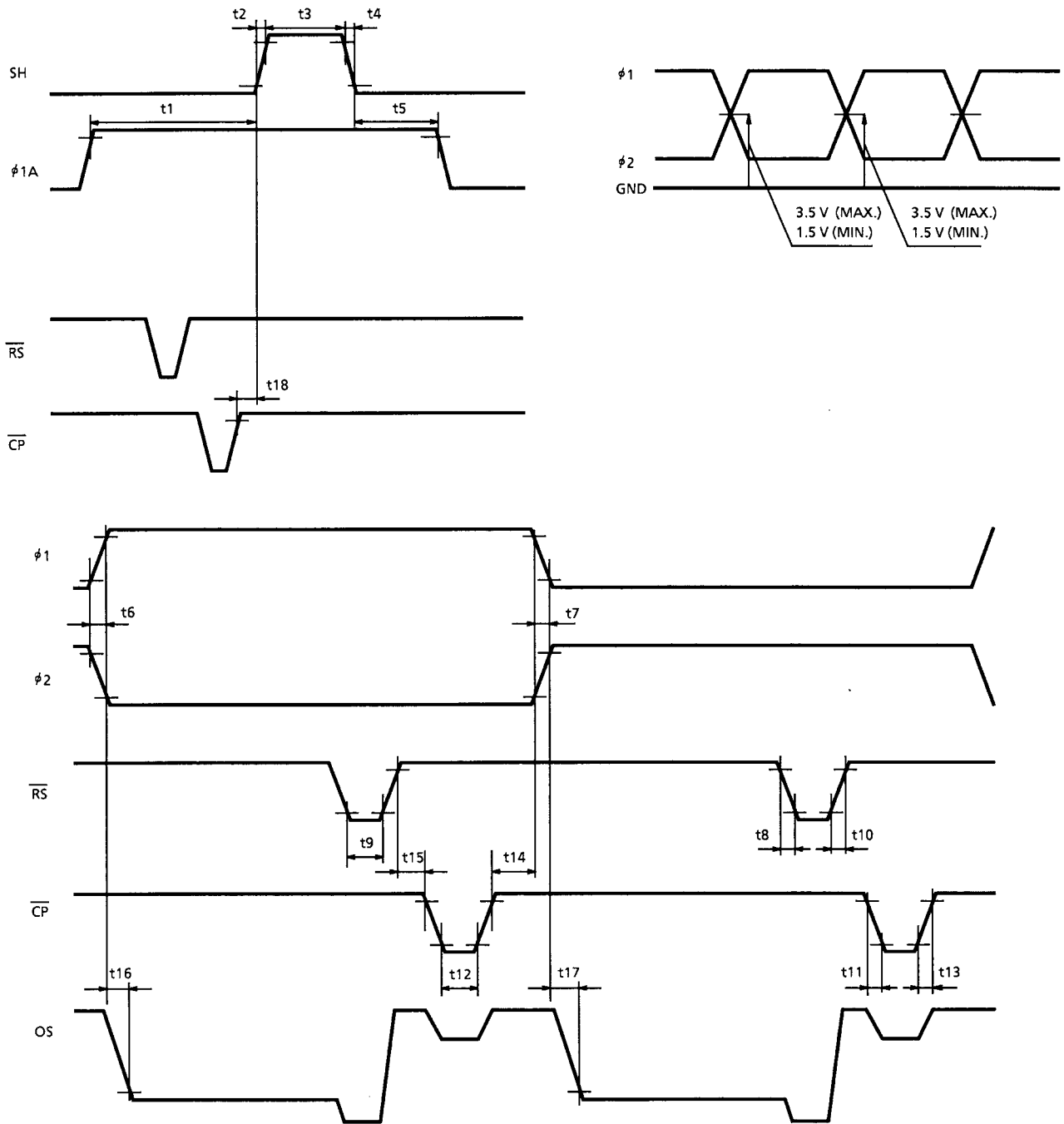

TIMING REQUIREMENTS (Cont'd)

CHARACTERISTIC	SYMBOL	MIN.	TYP. (Note 13)	MAX.	UNIT
Pulse Timing of SH and ϕ_{1A}	t1	110	1000	—	ns
	t5	200	1000	—	
SH Pulse Rise Time, Fall Time	t2, t4	0	50	—	ns
SH Pulse width	t3	1000	2000	—	ns
ϕ_1, ϕ_2 Pulse Rise Time, Fall Time	t6, t7	0	50	—	ns
\overline{RS} Pulse Rise Time, Fall Time	t8, t10	0	20	—	ns
\overline{RS} Pulse width	t9	45 (Note 15)	100	—	ns
\overline{CP} Pulse Rise Time, Fall Time	t11, t13	0	20	—	ns
\overline{CP} Pulse width	t12	40	100	—	ns
Pulse Timing of ϕ_{1A}, ϕ_{2A} and \overline{CP}	t14	20	40		ns
Pulse Timing of \overline{RS} and \overline{CP}	t15	45	100		ns
Video Data Delay Time (Note 14)	t16, t17	—	80	—	ns
Pulse Timing of SH and \overline{CP}	t18	0	500	—	ns

Note 13: TYP. is the case of $f_{\overline{RS}} = 1.0$ MHz.

Note 14: Load resistance is 100 k Ω .

Note 15: In line clamp operation, t9 is 70 ns (MIN.).

TYPICAL SPECTRAL RESPONSE

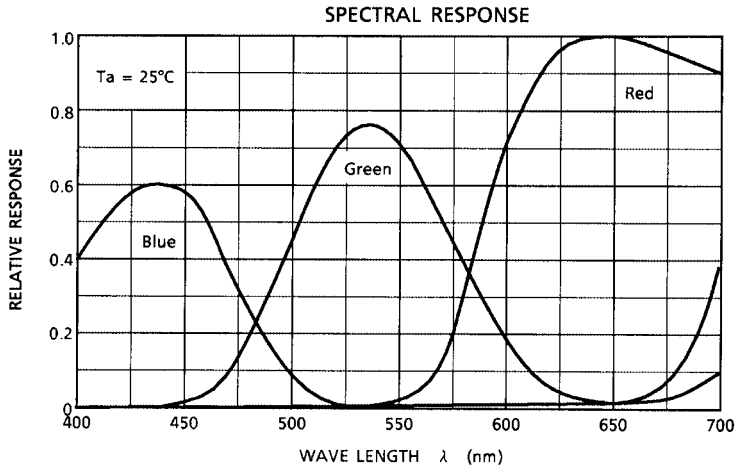

TYPICAL DRIVE CIRCUIT

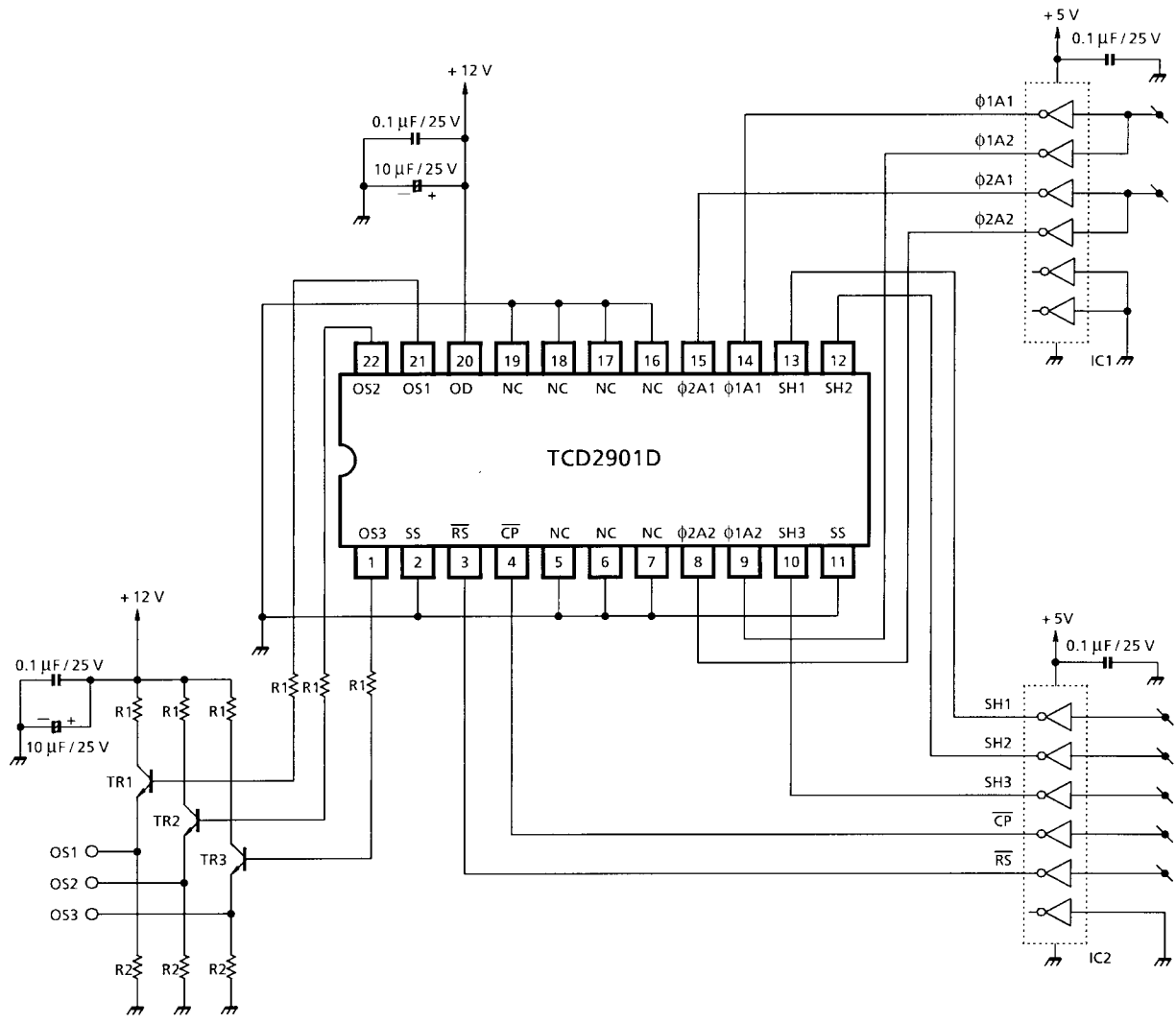

- IC1, 2 : TC74AC04AP
- TR1, 2, 3 : 2SC1815-Y
- R1 : 150 Ω
- R2 : 1500 Ω

CAUTION**1. Window Glass**

The dust and stain on the glass window of the package degrade optical performance of CCD sensor.

Keep the glass window clean by saturating a cotton swab in alcohol and lightly wiping the surface, and allow the glass to dry, by blowing with filtered dry N₂. Care should be taken to avoid mechanical or thermal shock because the glass window is easily to damage.

2. Electrostatic Breakdown

Store in shorting clip or in conductive foam to avoid electrostatic breakdown.

CCD Image Sensor is protected against static electricity, but interior puncture mode device due to static electricity is sometimes detected. In handing the device, it is necessary to execute the following static electricity preventive measures, in order to prevent the trouble rate increase of the manufacturing system due to static electricity.

- a. Prevent the generation of static electricity due to friction by making the work with bare hands or by putting on cotton gloves and non-charging working clothes.
- b. Discharge the static electricity by providing earth plate or earth wire on the floor, door or stand of the work room.
- c. Ground the tools such as soldering iron, radio cutting pliers or pincer.

It is not necessarily required to execute all precaution items for static electricity.

It is all right to mitigate the precautions by confirming that the trouble rate within the prescribed range.

3. Incident Light

CCD sensor is sensitive to infrared light. Note that infrared light component degrades resolution and PRNU of CCD sensor.

4. Lead Frame Forming

Since this package is not strong against mechanical stress, you should not reform the lead frame.

We recommend to use a IC-inserter when you assemble to PCB.

5. Soldering

Soldering by the solder flow method cannot be guaranteed because this method may have deleterious effects on prevention of window glass soiling and heat resistance.

Using a soldering iron, complete soldering within ten seconds for lead temperatures of up to 260°C, or within three seconds for lead temperatures of up to 350°C.

PACKAGE DIMENSIONS

WDIP22-G-400-2.54D (D)

Unit : mm

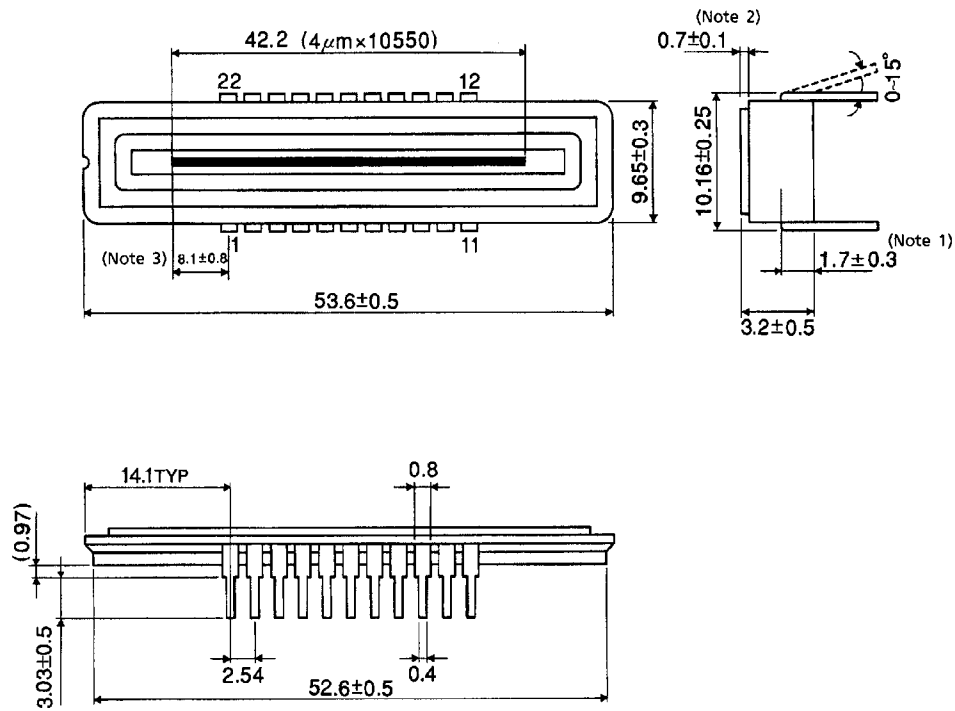

Note 1: TOP OF CHIP TO BOTTOM OF PACKAGE

Note 2: GLASS THICKNESS (n = 1.5)

Note 3: No.1 SENSOR ELEMENT (S1) TO CENTER OF No.1 PIN.

Weight: 5.2g (Typ.)

RESTRICTIONS ON PRODUCT USE

000707EBA

- TOSHIBA is continually working to improve the quality and reliability of its products. Nevertheless, semiconductor devices in general can malfunction or fail due to their inherent electrical sensitivity and vulnerability to physical stress. It is the responsibility of the buyer, when utilizing TOSHIBA products, to comply with the standards of safety in making a safe design for the entire system, and to avoid situations in which a malfunction or failure of such TOSHIBA products could cause loss of human life, bodily injury or damage to property.
In developing your designs, please ensure that TOSHIBA products are used within specified operating ranges as set forth in the most recent TOSHIBA products specifications. Also, please keep in mind the precautions and conditions set forth in the "Handling Guide for Semiconductor Devices," or "TOSHIBA Semiconductor Reliability Handbook" etc..
- The TOSHIBA products listed in this document are intended for usage in general electronics applications (computer, personal equipment, office equipment, measuring equipment, industrial robotics, domestic appliances, etc.). These TOSHIBA products are neither intended nor warranted for usage in equipment that requires extraordinarily high quality and/or reliability or a malfunction or failure of which may cause loss of human life or bodily injury ("Unintended Usage"). Unintended Usage include atomic energy control instruments, airplane or spaceship instruments, transportation instruments, traffic signal instruments, combustion control instruments, medical instruments, all types of safety devices, etc.. Unintended Usage of TOSHIBA products listed in this document shall be made at the customer's own risk.
- The products described in this document are subject to the foreign exchange and foreign trade laws.
- The information contained herein is presented only as a guide for the applications of our products. No responsibility is assumed by TOSHIBA CORPORATION for any infringements of intellectual property or other rights of the third parties which may result from its use. No license is granted by implication or otherwise under any intellectual property or other rights of TOSHIBA CORPORATION or others.
- The information contained herein is subject to change without notice.