



## **H6850 Series**

### **Novel Low Cost Green-Power PWM Controller**

### **With Low EMI Technique**

#### **Feature**

- Low Cost, PWM&PFM&CRM (Cycle Reset Mode)
  - Low Start-up Current (about 3μA)
  - Low Operating Current (about 1.2mA)
  - Current Mode Operation
  - Under Voltage Lockout (UVLO)
  - Built-in Synchronized Slope Compensation
  - Built-in Low EMI Technique
  - Programmable PWM Frequency
  - Audio Noise Free Operation
  - Leading edge Blanking on Sense input
  - Constant output power limiting for universal AC input Range
  - SOT-23-6L 、 SOP8 and DIP-8 Pb-Free
- Packaging
  - Good Protection Coverage With Auto Self-Recovery
  - Compatible with **SG6848 (6849) / SG5701/SG5848/LD7535 (7550) / OB2262 (2263)/OB2278 (2279)**
  - **Complete Protection with**
    - Soft Clamped GATE output voltage 18.0V
    - VDD over voltage protect 34.0V
    - Cycle-by-cycle current limiting
    - Output SCP (Short circuit Protection)
    - Output OLP (Over Load Protection)
    - High-Voltage CMOS Process with ESD

#### **Applications**

- Switching AC/DC Adaptor
- Battery Charger
- Open Frame Switching Power Supply
- Standby Power Supplies
- Set-Top Box Power Supplies
- 384X Replacement

#### **General Description**

The H6850 is a highly integrated low cost current mode PWM controller, which is ideal for small power current mode of offline AC-DC fly-back converter applications. Making use of external resistors, the IC changes the operating frequency and automatically enters the PFM/CRM (Cycle Reset Mode) under light-load/zero-load conditions. This can minimize standby power consumption and achieve power-saving functions. With a very low start-up current, the H6850 could use a large value start-up resistor (2MΩ).

Built-in synchronized slope compensation enhances the stability of the system and avoids sub-harmonic oscillation. Dynamic peak current limiting circuit minimizes output power change caused by delay time of the system over a universal AC input range.

Leading edge blanking circuit on current sense input could remove the signal glitch due to snubber circuit diode reverse recovery and thus greatly reduces the external component count and system cost in the design. Cycle-by-Cycle current limiting ensures safe operation even during short-circuit.

Excellent EMI performance is achieved built-in soft driver and low EMI technique.

The H6850 offers perfect protection like OVP(Over Voltage Protection)、OLP(Over Load Protection)、SCP(Short circuit protection)、OTP、Sense Fault Protection and OCP(Over current protection). The H6850's output driver is soft clamped to maximum 18.0V to protect the power MOSFET. H6850 is offered in SOT-23-6L, SOT-8 and DIP-8 packages.



## Pin Assignment

Part Number	Description
H6850NF	SOT26, Pb-free,in T/R
H6850S	SOP-8, Pb-free in T/R
H6850P	DIP-8, Pb-free in Tube

## Pin Descriptions

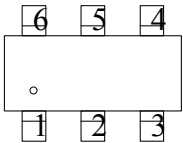
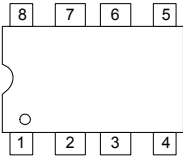
Package	Function		Description
	SOT-26	DIP-8	
 SOT-26	Pin6: GATE	Pin1: GATE	Totem-pole output to drive the external power MOSFET
	Pin5: VDD	Pin2: VDD	
		Pin3: NC	NC Pin.
	Pin4: SENSE	Pin4: SENSE	Current sense pin, a resistor connects to sense the MOSFET current.
	Pin3: RI	Pin5: RI	This pin is to program the switching frequency. By connecting a resistor to ground to set the switching frequency.
		Pin6: NC	NC Pin
 DIP -8(SOP-8)	Pin2: FB	Pin7:FB	Voltage feedback pin. Output current of this pin could controls the PWM duty cycle、OLP and SCP.
	Pin1: GND	Pin8: GND	GND Pin

## TYPICAL APPLICATION

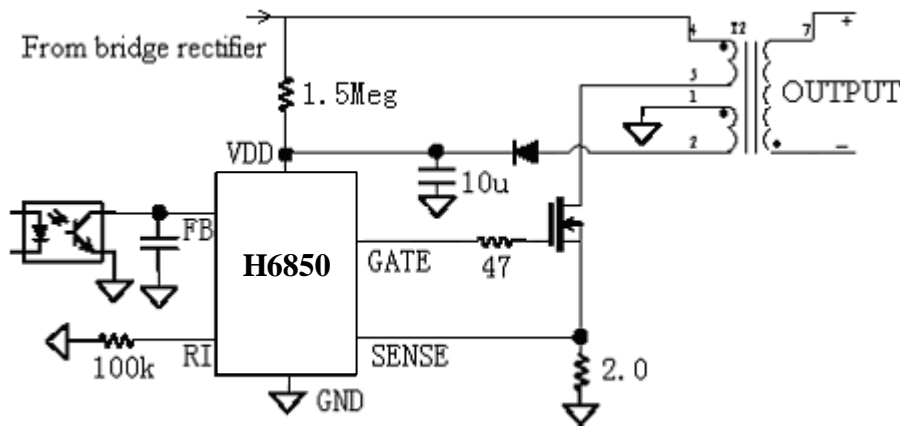



**Block Diagram**

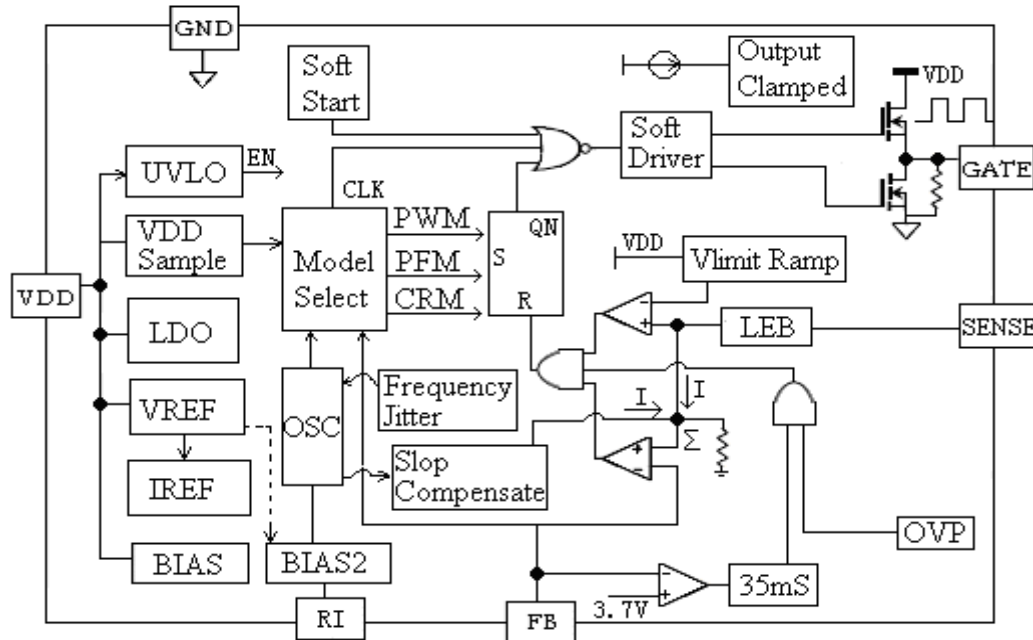

**Simplified Internal Circuit Architecture**

**Absolute Maximum Ratings**

Symbol	Parameter	Rating	Unit	
V <sub>DD</sub>	Supply voltage Pin Voltage	40	V	
I <sub>OVP</sub>	VDD OVP maximal enter current	20	mA	
V <sub>FB</sub>	Input Voltage to FB Pin	-0.3 to 6V	V	
V <sub>SEN</sub>	Input Voltage to SEN Pin	-0.3 to 6V	V	
P <sub>D</sub>	Power Dissipation	300	mW	
	ESD Capability, HBM Model	2500	V	
	ESD Capability, Machine Model	250	V	
T <sub>L</sub>	Lead Temperature (Soldering)	SOT-23-6L (20S)	220	°C
		DIP-8 (10S)	260	°C
		SOP-8 (10S)	230	°C
T <sub>STG</sub>	Storage Temperature Range	-55 to + 150	°C	

**RECOMMENDED OPERATION CONDITION**

Symbol	Parameter	Min ~ Max	Unit
V <sub>DD</sub>	VDD Supply Voltage	10~30	V
R <sub>I</sub>	R <sub>I</sub> PIN Resistor Value	100	K ohm
T <sub>OA</sub>	Operation Ambient Temperature	-20~85	°C
P <sub>OMAX</sub>	Maximal Output Power	0~80	W
F <sub>PWM</sub>	Frequency of PWM	30~150	kHz



**Electrical Characteristics** (Ta=25°C unless otherwise noted, V<sub>DD</sub> = 16V)

Symbol	Parameter	Conditions	Min.	Typ.	Max.	Unit
<b>Supply Voltage (V<sub>DD</sub> Pin)</b>						
I <sub>ST</sub>	Startup Current			3.0	20.0	μA
I <sub>SS</sub>	Operating Current	V <sub>FB</sub> =0V		3.0		mA
		V <sub>FB</sub> =3V		1.2		mA
		V <sub>FB</sub> =Open		0.8		mA
V <sub>DDON</sub>	Turn-on Threshold Voltage		13.0	14.0	15.0	V
V <sub>DDOFF</sub>	Turn-off Threshold Voltage		7.8	8.8	9.8	V
V <sub>DDCLAMP</sub>	VDD Clamp Voltage	I <sub>VDD</sub> =10mA		34.0		V
V <sub>DDAIS</sub>	Anti Intermission Surge VDD Voltage			9.4		V
<b>Voltage Feedback (FB Pin)</b>						
I <sub>FB</sub>	Short Circuit Current	V <sub>FB</sub> =0V		0.7		mA
V <sub>FB</sub>	Open Loop Voltage	V <sub>FB</sub> =Open		4.8		V
I <sub>FB_OD</sub>	Zero Duty Cycle FB current			0.59		mA
I <sub>PFM</sub>	Enter PFM FB current			0.50		mA
I <sub>CRM</sub>	Enter CRM FB current			0.55		mA
V <sub>PFM</sub>	Enter PFM Threshold V <sub>FB</sub>			1.80		V
V <sub>CRM</sub>	Enter CRM Threshold V <sub>FB</sub>			1.40		V
I <sub>OLP&amp;SCP</sub>	Enter OLP&SCP FB current			170		uA
V <sub>OLP&amp;SCP</sub>	Enter OLP&SCP FB voltage			3.7		V
T <sub>OLP&amp;SCP</sub>	OLP&SCP min. delay Time	RI=100K	33	35	50	mS
<b>Current Sensing (SEN Pin)</b>						
V <sub>TH_L</sub>	SEN Maximum Voltage Level (Dmin=0%)	RI=100K, FB=3.3V		0.80		V
V <sub>TH_H</sub>	SEN Maximum Voltage Level(Dmax=78%)	RI=100K, FB=3.3V		1.05		V
T <sub>PD</sub>	Delay to Output	FB=3.3V		75		ns



$R_{CS}$	Input Impedance			40		K $\Omega$
$T_{LEB}$	Leading edge blanking time (LEB)	RI=100K		300		nS
<b>Oscillator (RI Pin)</b>						
$F_{OSC}$	Normal Frequency	RI=100Kohm	60	65	70	KHz
$F_{PFM}$	PFM Frequency	RI=100Kohm		22		KHz
$DC_{MAX\_W}$	Maximum Duty Cycle PWM	RI=100Kohm		78		%
$DC_{MAX\_F}$	Maximum Duty Cycle PFM	RI=100Kohm		78		%
$\Delta F_{TEMP}$	Frequency Temp. Stability	-30-100°C		5		%
$T_{BLANK}$	Leading-Edge Blanking Time			300		nS
$F_{JITTER}$	Frequency jitter	RI=100Kohm	-4		4	%
<b>GATE Drive Output (GATE Pin)</b>						
$V_{OL}$	Output Low Level	$V_{DD}=16V,$ $I_O=20mA$			0.8	V
$V_{OH}$	Output High Level	$V_{DD}=16V,$ $I_O=20mA$	10			V
$T_{R1}$	Rising Time	$C_L=500pF$		123		ns
$T_{F1}$	Falling Time	$C_L=500pF$		71		ns
$T_{R2}$	Rising Time	$C_L=1000pF$		248		ns
$T_{F2}$	Falling Time	$C_L=1000pF$		116		ns
$T_{R3}$	Rising Time	$C_L=1500pF$		343		ns
$T_{F3}$	Falling Time	$C_L=1500pF$		153		ns
$T_{R4}$	Rising Time	$C_L=2000pF$		508		ns
$T_{F4}$	Falling Time	$C_L=2000pF$		209		ns
$V_{G\_CLAMP}$	Output Clamp Voltage	$V_{DD}=20V$		18.0		V
<b>Low EMI technique</b>						
$f_{EMI}$	Low EMI frequency	RI=100Kohm		65		KHz
$\Delta f_{osc}$	Frequency modulation range /Base frequency	RI=100Kohm	-3		3	%



## OPERATION DESCRIPTION

### Current Mode

Compared to voltage mode control, current mode control has a current feedback loop. When the voltage of the Sense resistor peak current of the primary winding reaches the internal setting value  $V_{TH}$ , the register resets and the power MOSFET cuts off. So, to detect and modulate the peak current cycle-by-cycle could control the output of the power supply. The current feedback has a good linear modulation rate and a fast input and output dynamic impact, and avoid the pole that the output filter inductance brings and the two-class system descends to the one-class. So it widens the frequency range and optimizes overload protection and short circuit protection.

### Startup Current and Under Voltage Lockout

The startup current of H6850 is set to be very low so that a large value startup resistor can be used to minimize the power loss. For AC to DC adaptor with universal input range design, a 2 M $\Omega$ , 1/8 W startup resistor and a 10uF/25V VDD hold capacitor could be used.

The turn-on and turn-off threshold of the H6850 is designed to 14V/8.8V. During startup, the hold-up capacitor must be charge to 14.0V through the startup resistor. The hysteresis is implemented to prevent the shutdown from the voltage dip during startup.

### Internal Bias and OSC Operation

A resistor connected between RI pin and GND pin sets the internal constant current source to charge or discharge the internal fixed capacitor. The charge time and discharge time determines the internal clock speed and the switching frequency. Increasing the resistance will reduce the value of the input current and reduce the switching frequency. The relationship between RI and PWM switching frequency follows the below equation within the RI allowed range.

$$F_{osc} = \frac{6500}{RI(K\Omega)}(kHz)$$

For example, a 100k $\Omega$  resistor RI could generate a 20uA constant current and a 65kHz PWM switching frequency. The suggested operating frequency range of H6850 is within 50KHz to 150KHz.

### Green Power Operation

The power dissipation of switching mode power supply is very important in zero load or light load condition. The major dissipation results from conduction loss, switching loss and consume of the control circuit. However, all of them relates to the switching frequency. There are many difference topologies has been implemented in different chip. The basic operation theory of all these approaches intends to reduce the switching frequency under light-load or no-load condition.

The H6850's green power function adapts PWM, PFM and CRM combining modulation. When RI resistor is 100k $\Omega$ , the PWM frequency is 65kHz in medium or heavy load operation. Through modifying the pulse width, The H6850 could control output voltage. The current of FB pin increases when the load is in light condition and the internal mode controller enters PFM&PWM when the feedback current is over 0.5mA. The operation frequency of oscillator is to descend gradually. When the feedback current is over 0.55mA, the frequency of oscillator is invariable, namely 22kHz.

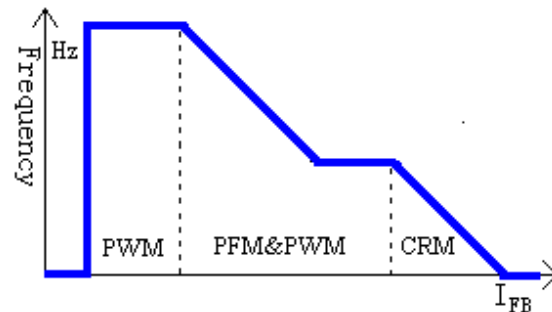

**H6850 Green-Power Function**



To decrease the standby consumption of the power supply, Chip-Rail introduces the Cycle Reset Mode technology (CRM). If the feedback current is over 0.59mA, mode controller of the H6850 would reset internal register all the time and cut off the GATE pin. While the output voltage is lower than the set value, the register would be set, the GATE pin operate again. So the frequency of the internal OSC is invariable, the register would reset some pulses so that the practical frequency is decreased at the GATE pin.

### Internal Synchronized Slop Compensation

Although there are more advantages of the current mode control than conventional voltage mode control, there are still several drawbacks of peak-sensing current-mode converter, especially the open loop instability when it operates in higher than 50% of the duty-cycle. To solve this problem, the H6850 is introduced an internal slope compensation adding voltage ramp to the current sense input voltage for PWM generation. It improves the close loop stability greatly at CCM, prevents the sub-harmonic oscillation and thus reduces the output ripple voltage.

$$V_{SLOP} = 0.33 \times \frac{DUTY}{DUTY_{MAX}} = 0.4389 \times DUTY$$

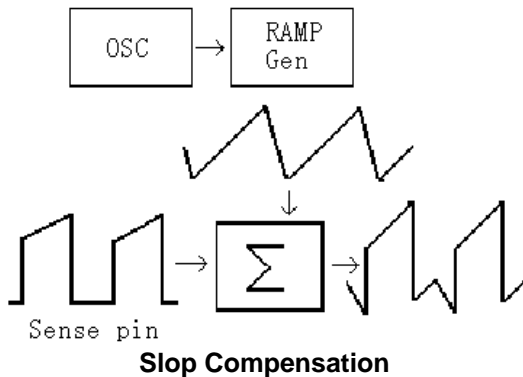

### Current Sensing & Dynamic peak limiting

The current flowing by the power

MOSFET comes into being a voltage  $V_{SENSE}$  on the Sense pin cycle-by-cycle, which compares to the internal reference voltage, and controls the reverse of the internal register, limits the peak current  $I_{MAX}$  of the primary of the transformer. The transformer

energy is  $E = \frac{1}{2} \times L \times I_{MAX}^2$ . So adjusting

the  $R_{SENSE}$  can set the maximal output power of the power supply. The current flowing by the power MOSFET has an extra

value ( $\Delta I = \frac{V_{IN}}{L_p} \times T_D$ ) due to the system

delay time that is from detecting the current through the Sense pin to power MOSFET off in the H6850 (Among these,  $V_{IN}$  is the primary winding voltage of the transformer and  $L_p$  is the primary wind inductance).  $V_{IN}$  ranges from 85VAC to 264VAC. To guarantee the output power is a constant for universal input AC voltage, there is a dynamic peak limit circuit to compensate the system delay T that the system delay brings on.

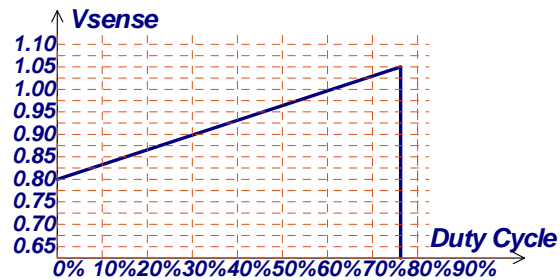

### OLP&SCP

To protect the circuit from being damaged under the over load or short circuit condition, a smart OLP&SCP function is implemented in the H6850. When short circuit or over load occurs in the output end, the feedback cycle would enhance the voltage of FB pin, while the voltage is over 3.7V or the current from FB is below 170uA, the internal detective circuit would send a signal to shut down the GATE and pull down the VDD voltage, then the circuit is restart. To avoid the wrong operation when circuit



starts, the delay time is set. When the RI resistance is 100Kohm, the delay time  $T_{OLP\&SCP}$  is between 33mS and 50mS. The relationship between RI and  $T_{OLP\&SCP}$  follows the below equation.

$$\frac{RI \times 2}{6 \times 10^3} (mS) < T_{OLP\&SCP} < \frac{RI \times 3}{6 \times 10^3} (mS)$$

### Anti Intermission Surge

When the power supplies change the heavy load to light load immediately, there could be tow phenomena caused by system delay. They are output voltage overshoot and intermission surge. To avoid it, the anti intermission surge is built in the H6850. If it occurs, the FB current is to increase rapidly, the GATE would be cut off for a while, VDD pin voltage descends gradually. When VDD reaches 9.4V, the GATE pin would operate again, which the frequency is 22KHz.

### Leading-edge Blanking (LEB)

Each time the power MOSFET is switched on, a turn-on spike will inevitably occur at the Sense pin, which would disturb the internal signal from the sampling of the  $R_{SENSE}$ . There is a 300nS leading edge blanking time built in to avoid the effect of the turn-on spike, and the power MOSFET cannot be switched off during the moment. So that the conventional external RC filtering on sense input is no longer required.

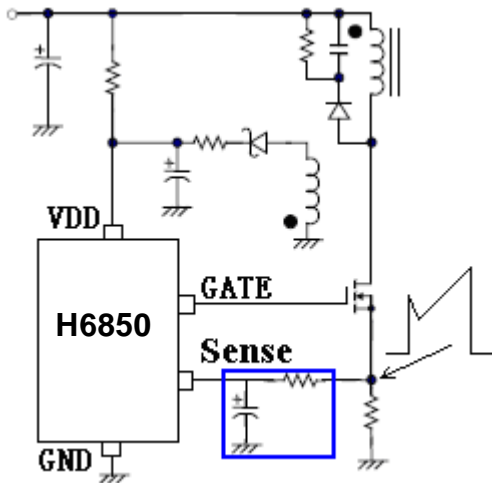

### Over Voltage Protection (OVP)

There is a 34V over-voltage protection circuit in the H6850 to improve the credibility and extend the life of the chip. When the VDD voltage is over 34V, the GATE pin is to shutdown immediately and the VDD voltage is to descend rapidly.

### GATE Driver & Soft Clamped

The H6850' output designs a totem pole to drive a periphery power MOSFET. The dead time is introduced to minimize the transfixion current during the output operating. The novel soft clamp technology is introduced to protect the periphery power MOSFET from breaking down and current saturation of the Zener.

### Low EMI technique

The frequency low EMI technique is introduced in the H6850. As following figure, the internal oscillation frequency is modulated by itself. A whole surge cycle includes 128 pulses and the jittering ranges from -4% to +4%. Thus, the function could minimize the electromagnetic interferer from the power supply module.

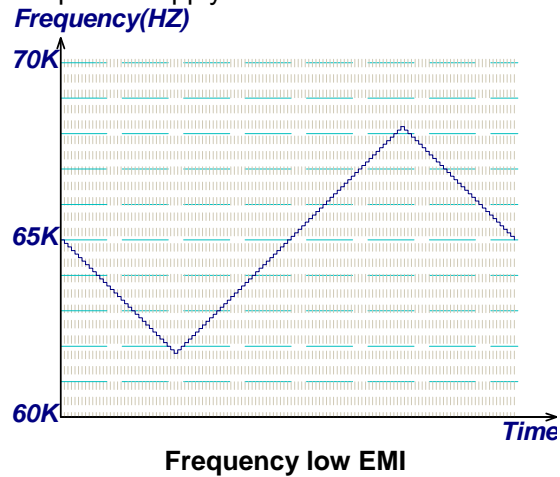





### CHARACTERIZATION PLOTS

VDD=16V,RI=100Kohm,TA=25°C condition applies if not otherwise noted.

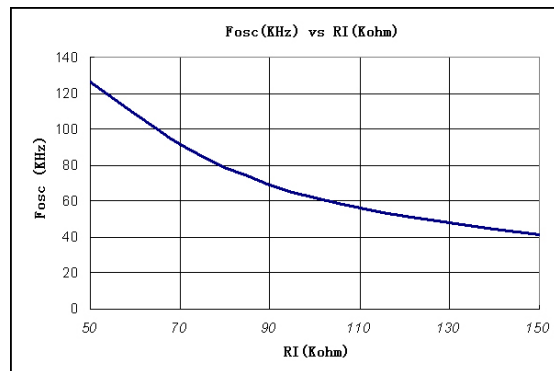
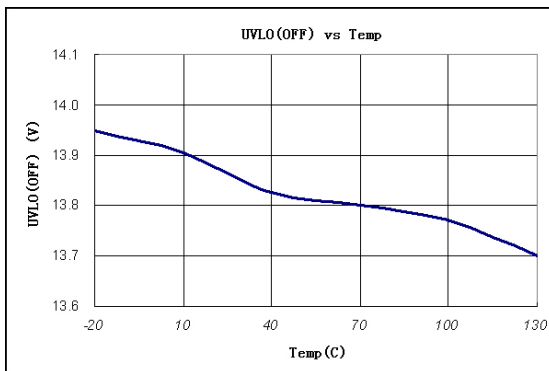
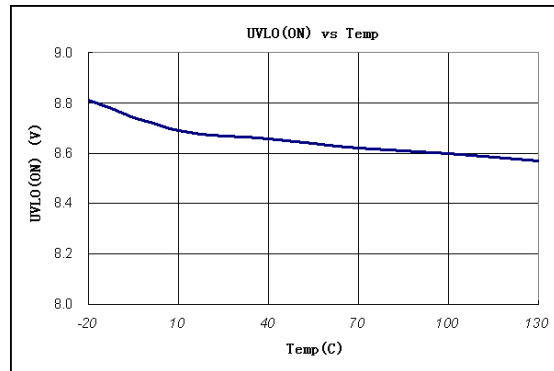
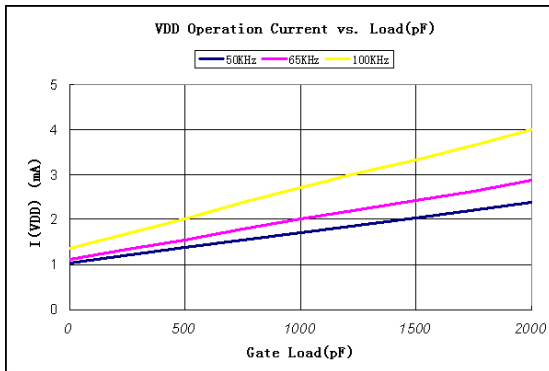
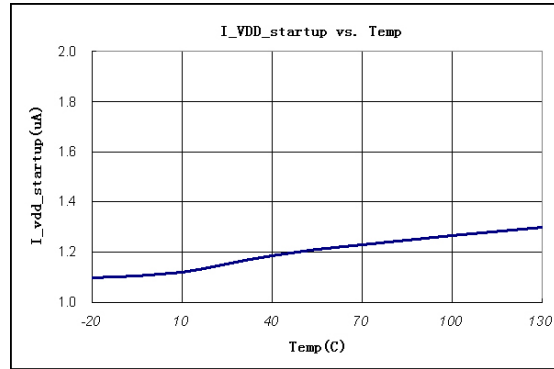
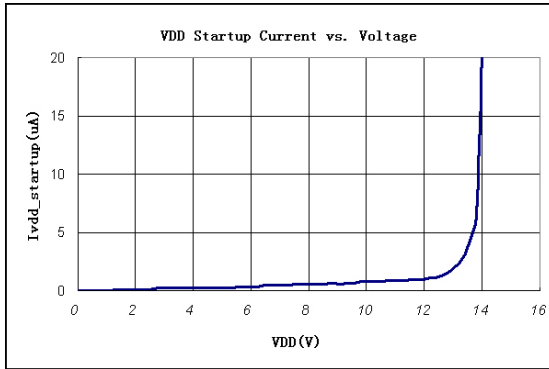

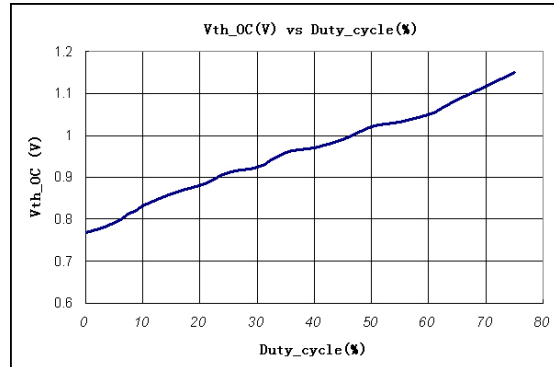
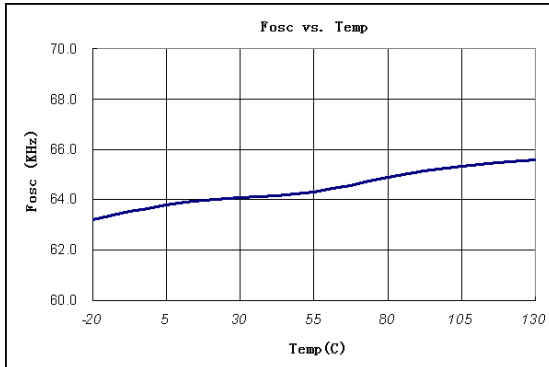



**PACKAGE DIMENSIONS**

**DIP-8L**

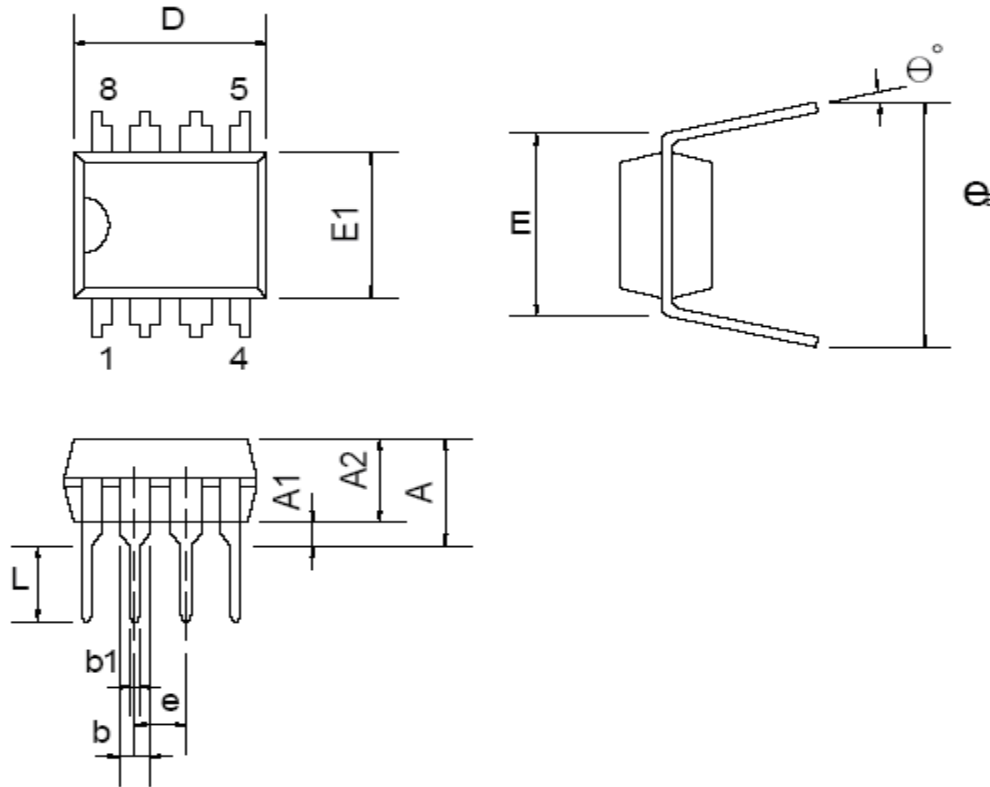

**Dimensions**

Symbol	Millimeters			Inches		
	Min.	Typ.	Max.	Min.	Typ.	Max.
A			5.334			0.210
A1	0.381			0.015		
A2	3.175	3.302	3.429	0.125	0.130	0.135
b		1.524			0.060	
b1		0.457			0.018	
D	9.017	9.271	10.160	0.355	0.365	0.400
E		7.620			0.300	
E1	6.223	6.350	6.477	0.245	0.250	0.255
e		2.540			0.100	
L	2.921	3.302	3.810	0.115	0.130	0.150
eB	8.509	9.017	9.525	0.335	0.355	0.375
θ°	0°	7°	15°	0°	7°	15°



**SOT-23-6L**

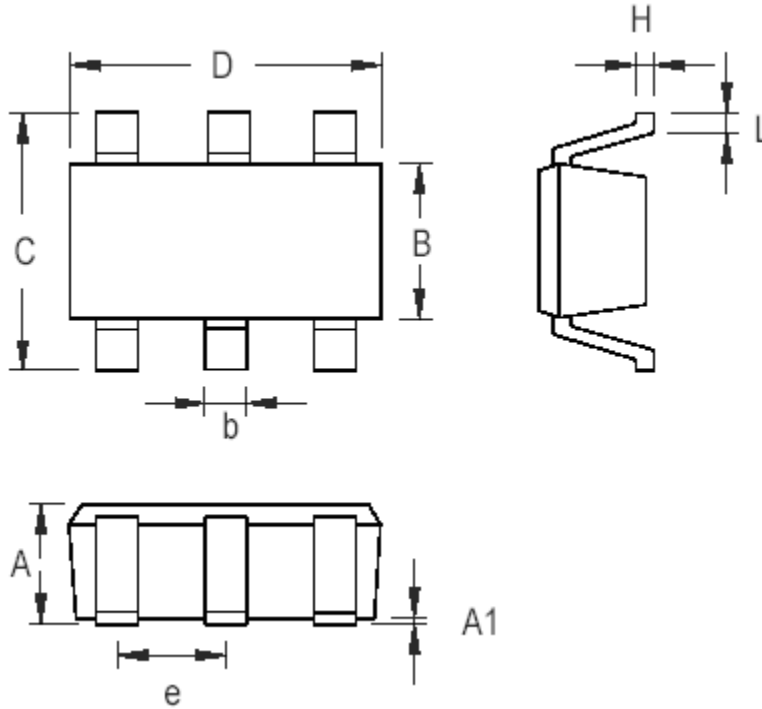

Symbol	Dimensions In Millimeters		Dimensions In Inches	
	Min	Max	Min	Max
A	0.700	1.000	0.028	0.039
A1	0.000	0.100	0.000	0.004
B	1.397	1.803	0.055	0.071
b	0.300	0.559	0.012	0.022
C	2.591	3.000	0.102	0.118
D	2.692	3.099	0.106	0.122
e	0.838	1.041	0.033	0.041
H	0.080	0.254	0.003	0.010
L	0.300	0.610	0.012	0.024



**SOP-8L**

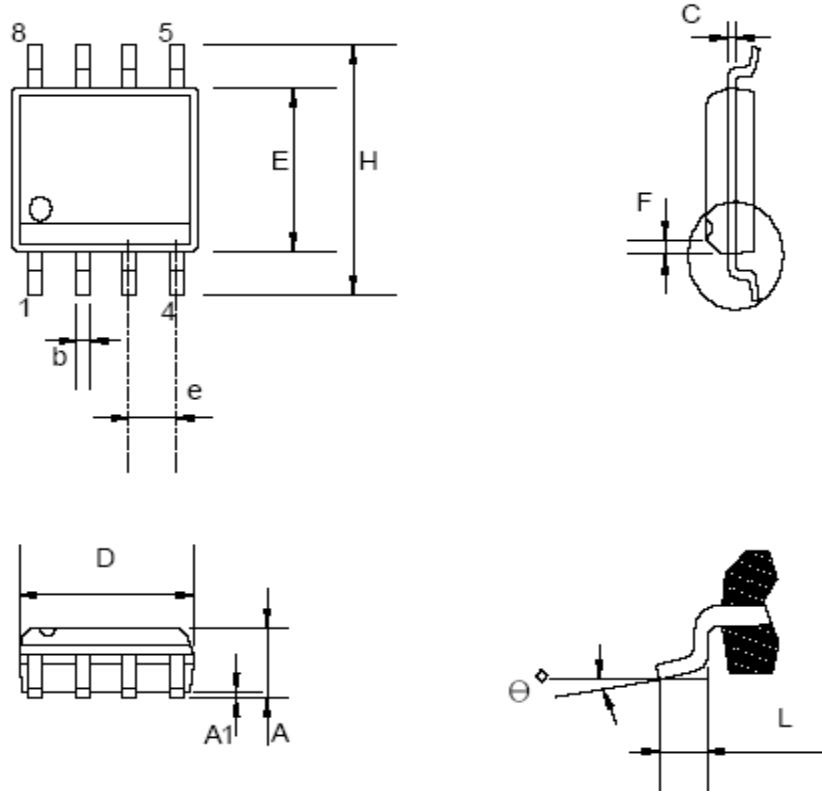

**Dimensions DISCLAIMERS**

Symbol	Millimeter			Inch		
	Min.	Typ.	Max.	Min.	Typ.	Max.
A	1.346		1.752	0.053		0.069
A1	0.101		0.254	0.004		0.010
b		0.406			0.016	
c		0.203			0.008	
D	4.648		4.978	0.183		0.196
E	3.810		3.987	0.150		0.157
e	1.016	1.270	1.524	0.040	0.050	0.060
F		0.381X45			0.015X45	
H	5.791		6.197	0.228		0.244
L	0.406		1.270	0.016		0.050
θ°	0°		8°	0°		8°