



# STB140NF55 STP140NF55

## N-CHANNEL 55V - 0.0065 Ω - 80A TO-220/D<sup>2</sup>PAK STripFET™ II POWER MOSFET

**Table 1: General Features**

TYPE	V <sub>DSS</sub>	R <sub>DS(on)</sub>	I <sub>D</sub>
STB140NF55	55 V	< 0.008 Ω	80 A
STP140NF55	55 V	< 0.008 Ω	80 A

- TYPICAL R<sub>DS(on)</sub> = 0.0065 Ω

### DESCRIPTION

This Power Mosfet is the latest development of STMicroelectronics unique "Single Feature Size™" strip-based process. The resulting transistor shows extremely high packing density for low on-resistance, rugged avalanche characteristics and less critical alignment steps therefore a remarkable manufacturing reproducibility.

### APPLICATIONS

- MOTOR CONTROL
- HIGH CURRENT, SWITCHING APPLICATIONS
- AUTOMOTIVE ENVIRONMENT

**Figure 1: Package**

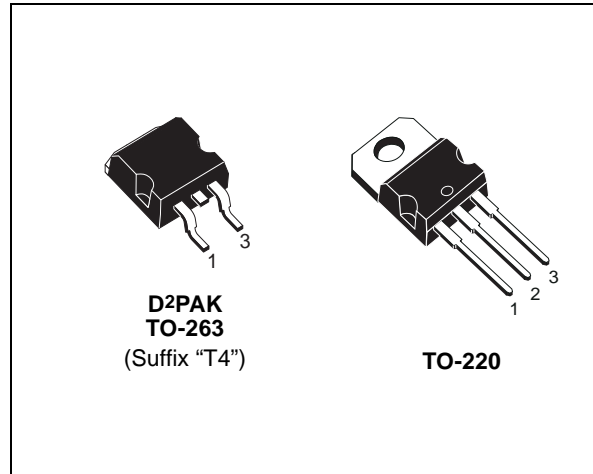

**Figure 2: Internal Schematic Diagram**

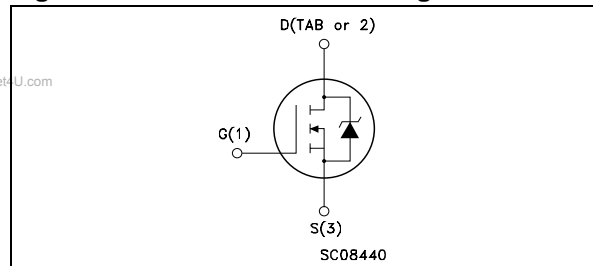

**Table 2: Order Codes**

Part Number	MARKING	PACKAGE	PACKAGING
STB140NF55T4	B140NF55	D <sup>2</sup> PAK	TAPE & REEL
STP140NF55	P140NF55	TO-220	TUBE

**Table 3: ABSOLUTE MAXIMUM RATINGS**

Symbol	Parameter	Value	Unit
V <sub>DS</sub>	Drain-source Voltage (V <sub>GS</sub> = 0)	55	V
V <sub>GS</sub>	Gate- source Voltage	± 20	V
I <sub>D</sub>	Drain Current (continuous) at T <sub>C</sub> = 25°C	80	A
I <sub>D</sub>	Drain Current (continuous) at T <sub>C</sub> = 100°C	80	A
I <sub>DM</sub> (●)	Drain Current (pulsed)	320	A
P <sub>tot</sub>	Total Dissipation at T <sub>C</sub> = 25°C	300	W
	Derating Factor	2	W/°C
dv/dt <sup>(1)</sup>	Peak Diode Recovery voltage slope	10	V/ns
E <sub>AS</sub> (2)	Single Pulse Avalanche Energy	1.3	mJ
T <sub>stg</sub>	Storage Temperature	-55 to 175	°C
T <sub>j</sub>	Operating Junction Temperature		

(●) Pulse width limited by safe operating area.

(\*\*) Current Limited by Package

(1) I<sub>SD</sub> ≤ 80A, di/dt ≤ 300A/μs, V<sub>DD</sub> ≤ V<sub>(BR)DSS</sub>, T<sub>j</sub> ≤ T<sub>JMAX</sub>

(2) Starting T<sub>j</sub> = 25 °C, I<sub>D</sub> = 40A, V<sub>DD</sub> = 30V

## STB140NF55 STP140NF55

**Table 4: THERMAL DATA**

Rthj-case	Thermal Resistance Junction-case	Max	0.5	°C/W
Rthj-amb	Thermal Resistance Junction-ambient	Max	62.5	°C/W
T <sub>l</sub>	Maximum Lead Temperature For Soldering Purpose		300	°C

### ELECTRICAL CHARACTERISTICS (T<sub>case</sub> = 25 °C unless otherwise specified)

**Table 5: OFF**

Symbol	Parameter	Test Conditions	Min.	Typ.	Max.	Unit
V <sub>(BR)DSS</sub>	Drain-source Breakdown Voltage	I <sub>D</sub> = 250 μA, V <sub>GS</sub> = 0	55			V
I <sub>DSS</sub>	Zero Gate Voltage Drain Current (V <sub>GS</sub> = 0)	V <sub>DS</sub> = Max Rating V <sub>DS</sub> = Max Rating T <sub>C</sub> = 125°C			1 10	μA μA
I <sub>GSS</sub>	Gate-body Leakage Current (V <sub>DS</sub> = 0)	V <sub>GS</sub> = ± 20 V			±100	nA

**Table 6: ON (\*)**

Symbol	Parameter	Test Conditions	Min.	Typ.	Max.	Unit
V <sub>GS(th)</sub>	Gate Threshold Voltage	V <sub>DS</sub> = V <sub>GS</sub> I <sub>D</sub> = 250 μA	2	3	4	V
R <sub>DS(on)</sub>	Static Drain-source On Resistance	V <sub>GS</sub> = 10 V I <sub>D</sub> = 40 A		0.0065	0.008	Ω

**Table 7: DYNAMIC**

Symbol	Parameter	Test Conditions	Min.	Typ.	Max.	Unit
g <sub>fs</sub> (*)	Forward Transconductance	V <sub>DS</sub> = 25 V I <sub>D</sub> = 40 A		100		S
C <sub>iss</sub>	Input Capacitance	V <sub>DS</sub> = 25V f = 1 MHz V <sub>GS</sub> = 0		5300		pF
C <sub>oss</sub>	Output Capacitance			1000		pF
C <sub>rss</sub>	Reverse Transfer Capacitance			290		pF

ELECTRICAL CHARACTERISTICS (continued)

Table 8: SWITCHING ON

Symbol	Parameter	Test Conditions	Min.	Typ.	Max.	Unit
$t_{d(on)}$ $t_r$	Turn-on Delay Time Rise Time	$V_{DD} = 27.5\text{ V}$ $I_D = 40\text{ A}$ $R_G = 4.7\ \Omega$ $V_{GS} = 10\text{ V}$ (Resistive Load, Figure 3)		30 150		ns ns
$Q_g$ $Q_{gs}$ $Q_{gd}$	Total Gate Charge Gate-Source Charge Gate-Drain Charge	$V_{DD} = 44\text{ V}$ $I_D = 80\text{ A}$ $V_{GS} = 10\text{ V}$		142 27 55		nC nC nC

Table 9: SWITCHING OFF

Symbol	Parameter	Test Conditions	Min.	Typ.	Max.	Unit
$t_{d(off)}$ $t_f$	Turn-off Delay Time Fall Time	$V_{DD} = 27.5\text{ V}$ $I_D = 40\text{ A}$ $R_G = 4.7\ \Omega$ $V_{GS} = 10\text{ V}$ (Resistive Load, Figure 3)		125 45		ns ns

Table 10: SOURCE DRAIN DIODE

Symbol	Parameter	Test Conditions	Min.	Typ.	Max.	Unit
$I_{SD}$ $I_{SDM} (\bullet)$	Source-drain Current Source-drain Current (pulsed)				80 320	A A
$V_{SD} (*)$	Forward On Voltage	$I_{SD} = 80\text{ A}$ $V_{GS} = 0$			1.5	V
$t_{rr}$ $Q_{rr}$ $I_{RRM}$	Reverse Recovery Time Reverse Recovery Charge Reverse Recovery Current	$I_{SD} = 80\text{ A}$ $di/dt = 100\text{ A}/\mu\text{s}$ $V_{DD} = 20\text{ V}$ $T_j = 150^\circ\text{C}$ (see test circuit, Figure 5)		90 275 6.5		ns $\mu\text{C}$ A

(\*)Pulsed: Pulse duration = 300  $\mu\text{s}$ , duty cycle 1.5 %.  
 (•)Pulse width limited by safe operating area.

Figure 3: Safe Operating Area

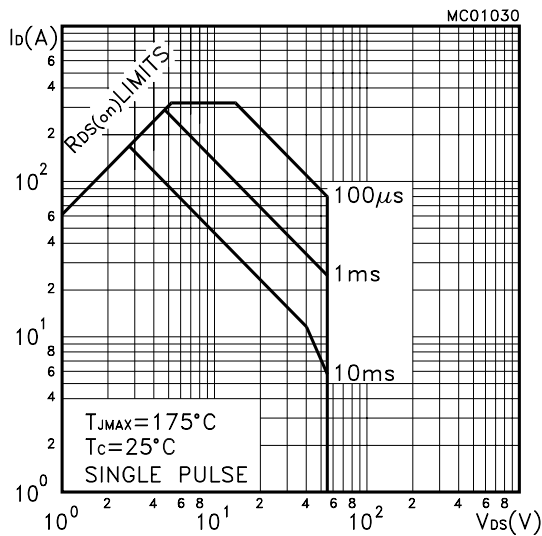

Figure 4: Thermal Impedance

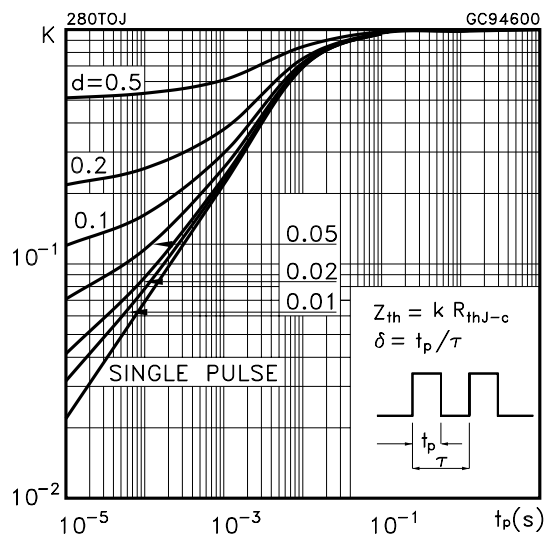

Figure 5: Output Characteristics

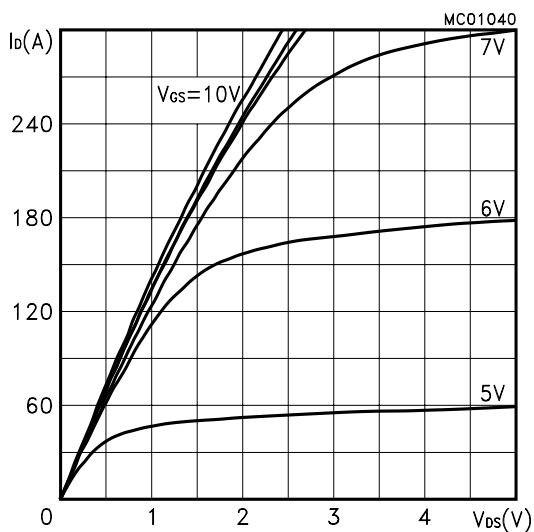

Figure 6: Transfer Characteristics

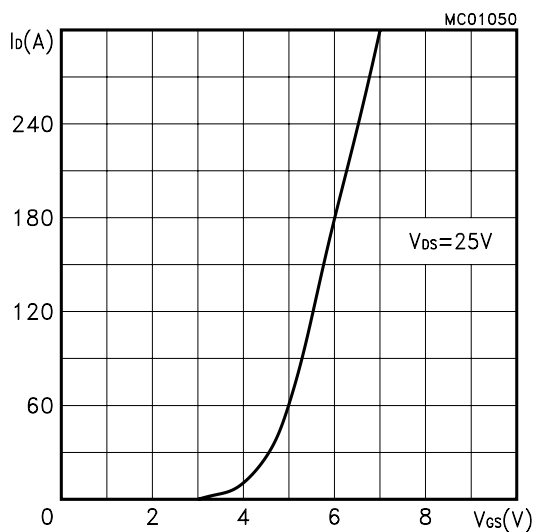

Figure 7: Transconductance

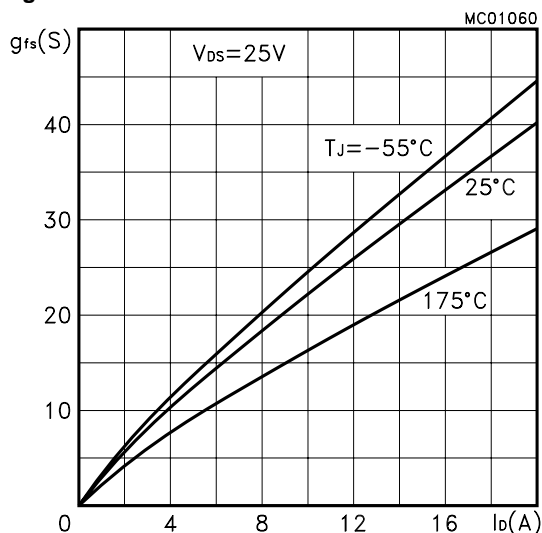

Figure 8: Static Drain-source On Resistance

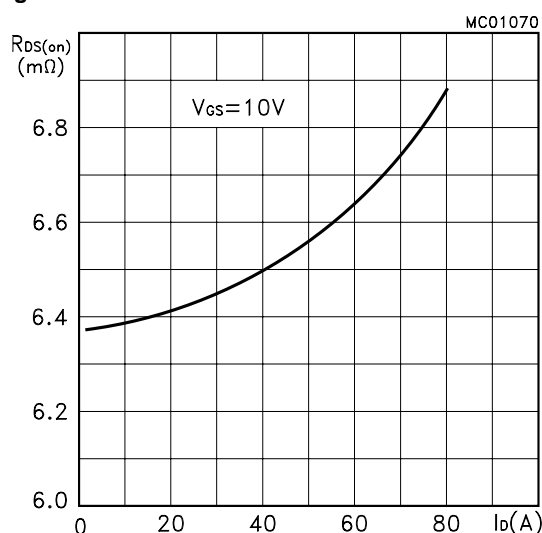

Figure 9: Gate Charge vs Gate-source Voltage

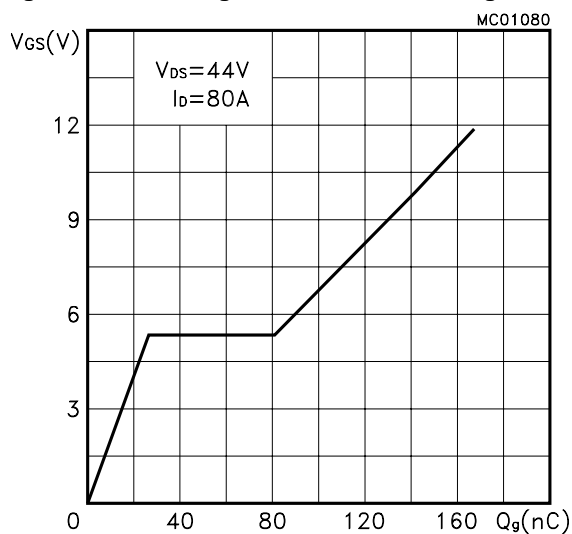

Figure 10: Capacitance Variations

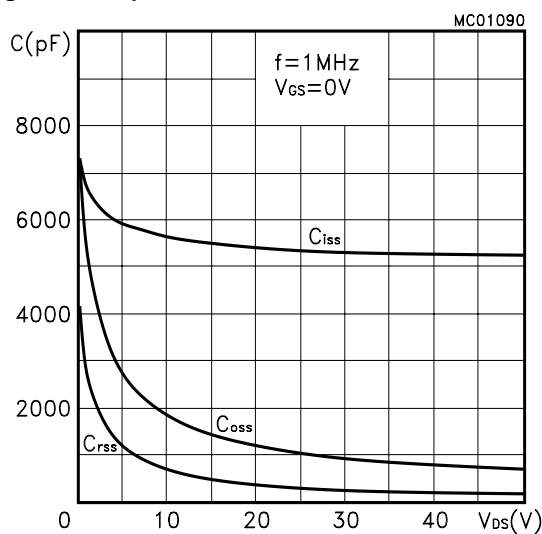

Figure 11: Normalized Gate Threshold Voltage vs Temperature

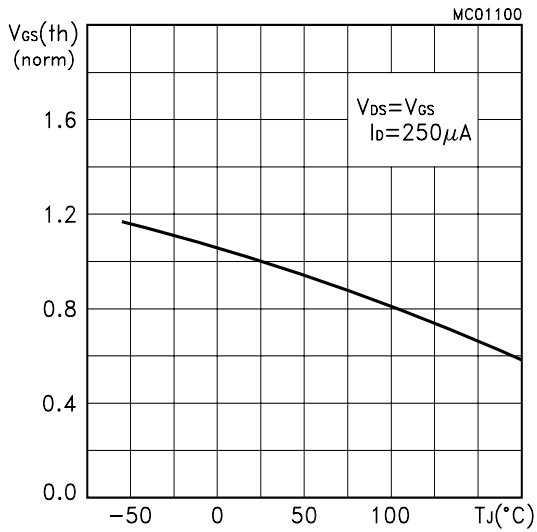

Figure 12: Normalized on Resistance vs Temperature

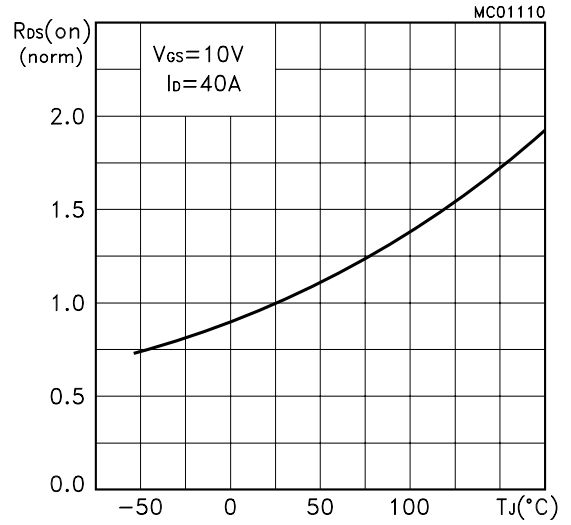

Figure 13: Source-drain Diode Forward Characteristics

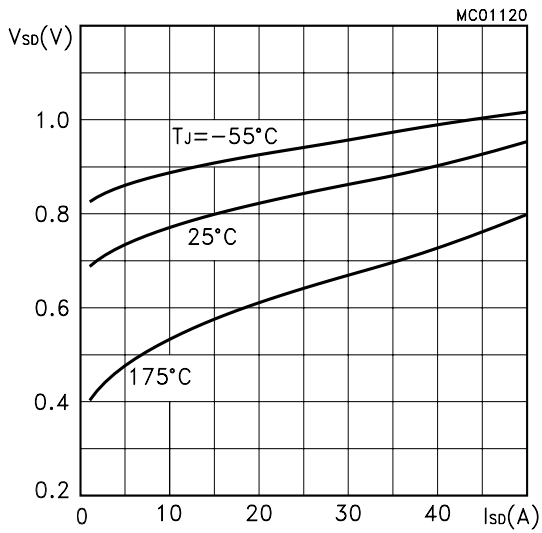

Figure 14: Normalized Breakdown Voltage vs Temperature.

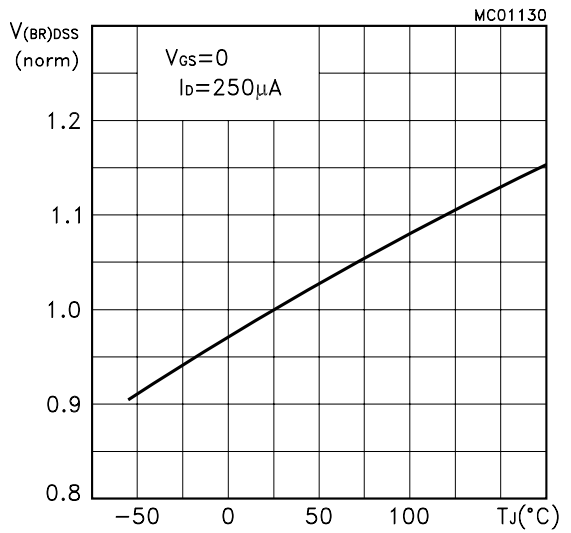

Figure 15: Unclamped Inductive Load Test Cir-

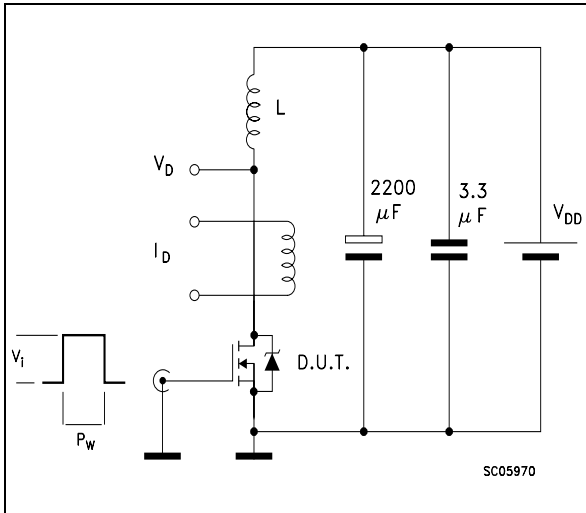

Figure 16: Unclamped Inductive Waveform

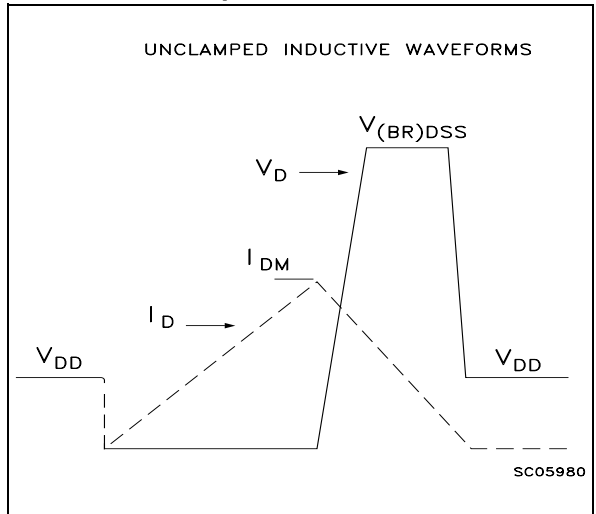

Figure 17: Switching Times Test Circuits For Resistive Load

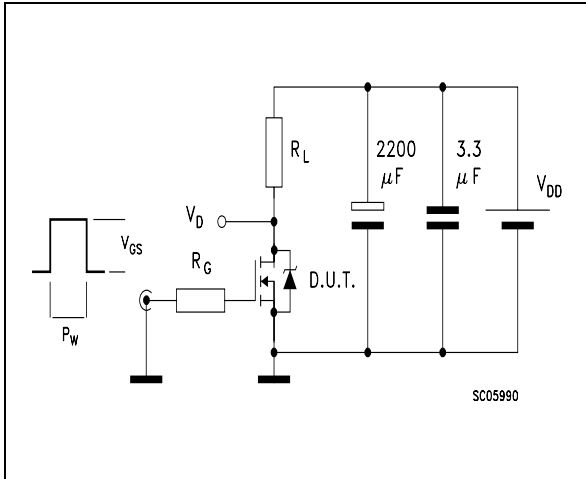

Figure 18: Gate Charge test Circuit

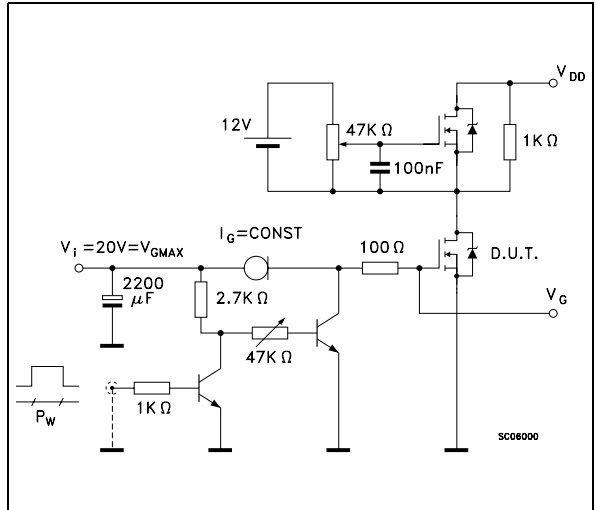
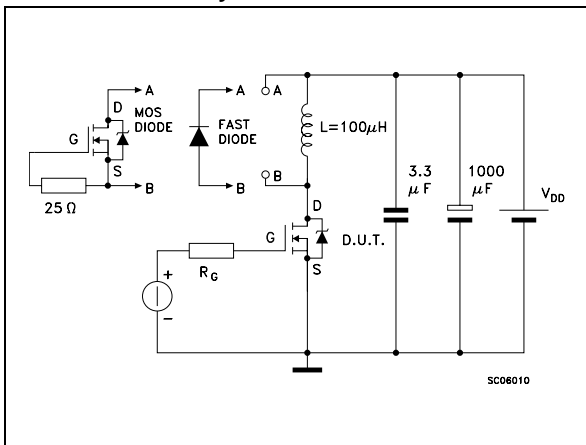
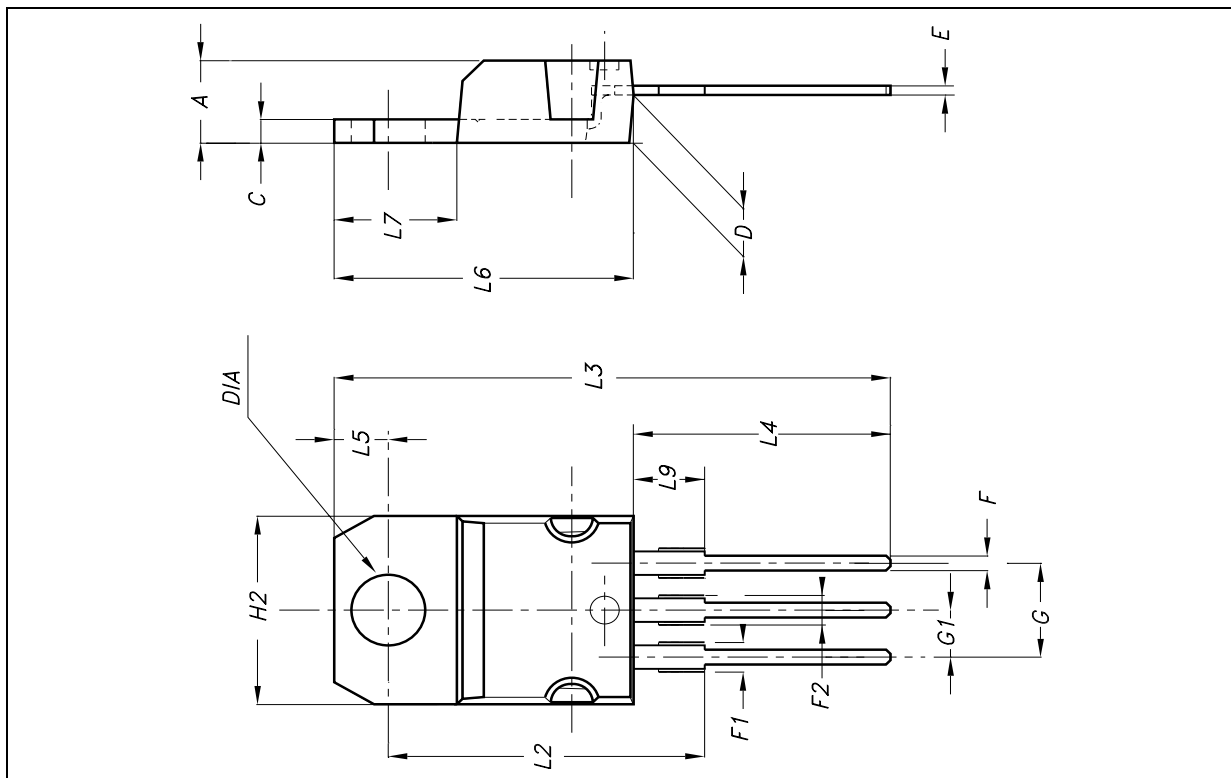

Figure 19: Test Circuit For Inductive Load Switching And Diode Recovery Times



TO-220 MECHANICAL DATA

DIM.	mm.			inch.		
	MIN.	TYP.	MAX.	MIN.	TYP.	TYP.
A	4.4		4.6	0.173		0.181
C	1.23		1.32	0.048		0.051
D	2.40		2.72	0.094		0.107
E	0.49		0.70	0.019		0.027
F	0.61		0.88	0.024		0.034
F1	1.14		1.70	0.044		0.067
F2	1.14		1.70	0.044		0.067
G	4.95		5.15	0.194		0.203
G1	2.40		2.70	0.094		0.106
H2	10		10.40	0.393		0.409
L2		16.40			0.645	
L3		28.90			1.137	
L4	13		14	0.511		0.551
L5	2.65		2.95	0.104		0.116
L6	15.25		15.75	0.600		0.620
L7	6.20		6.60	0.244		0.260
L9	3.50		3.93	0.137		0.154
DIA	3.75		3.85	0.147		0.151



**D<sup>2</sup>PAK MECHANICAL DATA**

DIM.	mm.			inch.		
	MIN.	TYP.	MAX.	MIN.	TYP.	TYP.
A	4.4		4.6	0.173		0.181
A1	2.49		2.69	0.098		0.106
A2	0.03		0.23	0.001		0.009
B	0.7		0.93	0.028		0.037
B2	1.14		1.7	0.045		0.067
C	0.45		0.6	0.018		0.024
C2	1.21		1.36	0.048		0.054
D	8.95		9.35	0.352		0.368
D1		8			0.315	
E	10		10.4	0.394		0.409
E1		8.5			0.334	
G	4.88		5.28	0.192		0.208
L	15		15.85	0.591		0.624
L2	1.27		1.4	0.050		0.055
L3	1.4		1.75	0.055		0.069
M	2.4		3.2	0.094		0.126
R		0.4			0.015	
V2	0°		8°	0°		8°

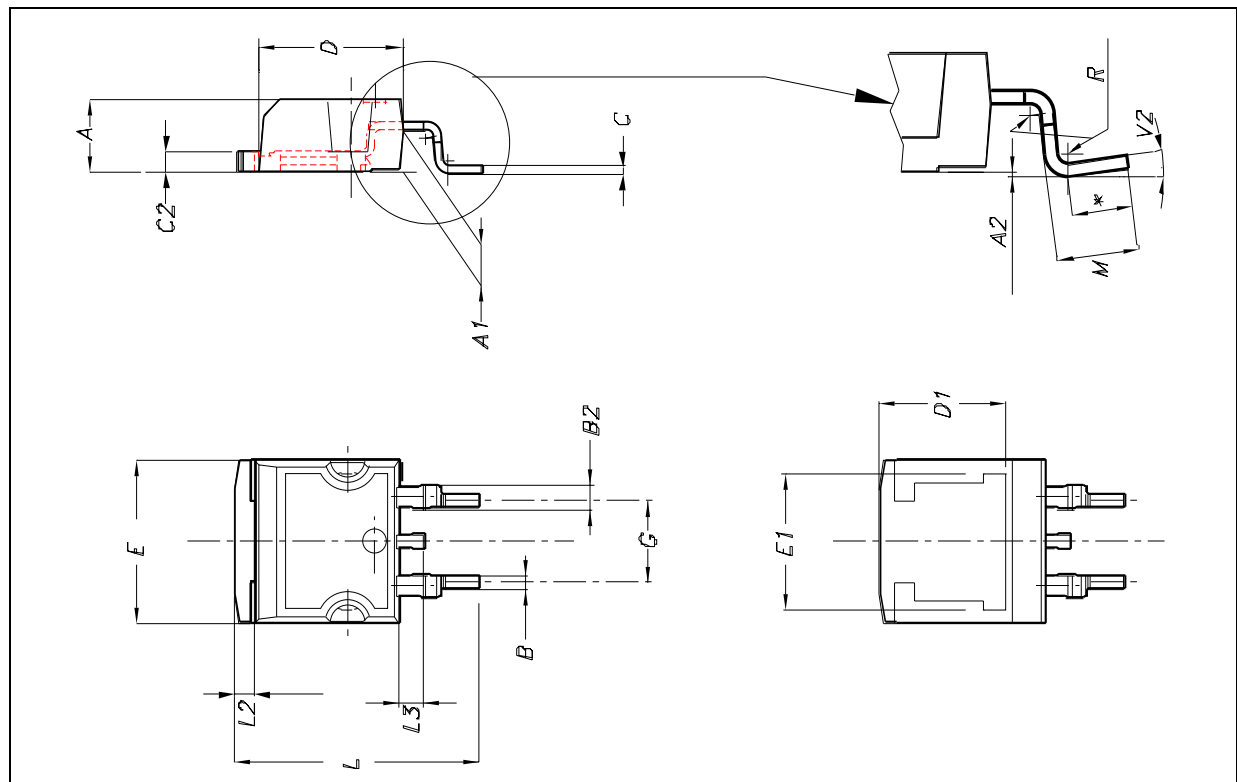



**D2PAK FOOTPRINT**

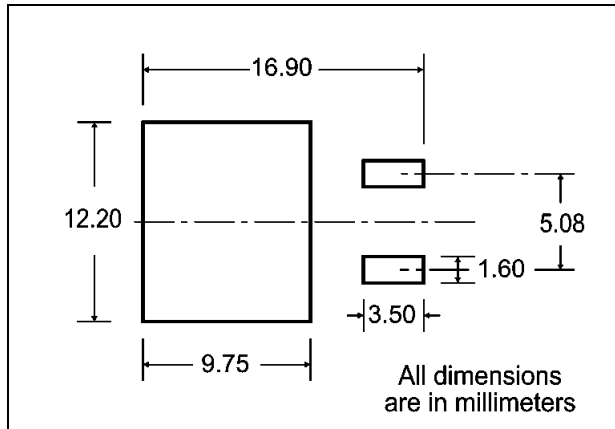

**TUBE SHIPMENT (no suffix)\***

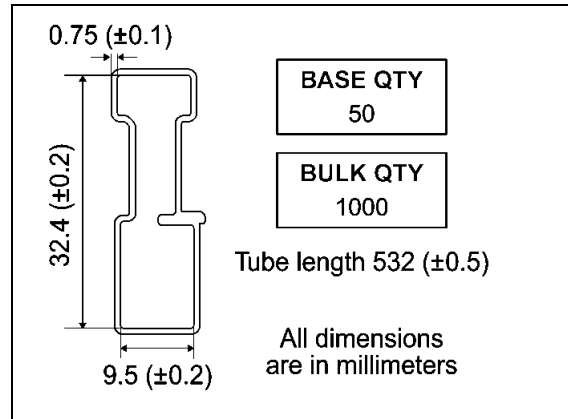

**TAPE AND REEL SHIPMENT (suffix "T4")\***

Diagram showing the tape and reel shipment details. The top view shows a circular reel with a diameter of A. The tape has a width of B and a slot width of D. The distance from the center of the reel to the center of the tape slot is C. The distance from the center of the reel to the center of the tape slot is N. The distance from the center of the reel to the center of the tape slot is G, measured at the hub. The tape slot in the core for tape start has a width of 2.5 mm min. The access hole at the slot location has a diameter of 40 mm min. The full radius of the reel is also indicated.

**REEL MECHANICAL DATA**

DIM.	mm		inch	
	MIN.	MAX.	MIN.	MAX.
A		330		12.992
B	1.5		0.059	
C	12.8	13.2	0.504	0.520
D	20.2		0.795	
G	24.4	26.4	0.960	1.039
N	100		3.937	
T		30.4		1.197

BASE QTY	BULK QTY
1000	1000

**TAPE MECHANICAL DATA**

DIM.	mm		inch	
	MIN.	MAX.	MIN.	MAX.
A0	10.5	10.7	0.413	0.421
B0	15.7	15.9	0.618	0.626
D	1.5	1.6	0.059	0.063
D1	1.59	1.61	0.062	0.063
E	1.65	1.85	0.065	0.073
F	11.4	11.6	0.449	0.456
K0	4.8	5.0	0.189	0.197
P0	3.9	4.1	0.153	0.161
P1	11.9	12.1	0.468	0.476
P2	1.9	2.1	0.075	0.082
R	50		1.574	
T	0.25	0.35	0.0098	0.0137
W	23.7	24.3	0.933	0.956

Diagram showing the tape mechanical data. The top view shows the tape with dimensions K0, D, P0, E, F, W, B0, D1, A0, P1, and P2. The center line of the cavity is also indicated. The user direction of feed is shown. The bending radius is R min. The feed direction is also shown.

\* on sales type



## STB140NF55 STP140NF55

---

**Table 11:Revision History**

Date	Revision	Description of Changes
07-Nov-2004	2	updated fig.14

Information furnished is believed to be accurate and reliable. However, STMicroelectronics assumes no responsibility for the consequences of use of such information nor for any infringement of patents or other rights of third parties which may result from its use. No license is granted by implication or otherwise under any patent or patent rights of STMicroelectronics. Specifications mentioned in this publication are subject to change without notice. This publication supersedes and replaces all information previously supplied. STMicroelectronics products are not authorized for use as critical components in life support devices or systems without express written approval of STMicroelectronics.

The ST logo is registered trademark of STMicroelectronics  
All other names are the property of their respective owners.

© 2004 STMicroelectronics - All Rights Reserved

STMicroelectronics group of companies  
Australia - Belgium - Brazil - Canada - China - Czech Republic - Finland - France - Germany - Hong Kong - India - Israel - Italy - Japan -  
Malaysia - Malta - Morocco -Singapore - Spain - Sweden - Switzerland - United Kingdom - United States of America.  
[www.st.com](http://www.st.com)