

TOSHIBA CMOS DIGITAL INTEGRATED CIRCUIT SILICON MONOLITHIC

**TC74HC245AP, TC74HC245AF, TC74HC245AFW  
TC74HC640AP, TC74HC640AF**

**OCTAL BUS TRANSCEIVER**

**TC74HC245AP / AF / AFW 3— STATE, NON—INVERTING**  
**TC74HC640AP / AF 3— STATE, INVERTING**

(Note) The JEDEC SOP (FW) is not available in Japan.

The TC74HC245A, 640A are high speed CMOS OCTAL BUS TRANSCEIVERS fabricated with silicon gate C<sup>2</sup>MOS technology.

They achieve the high speed operation similar to equivalent LSTTL while maintaining the CMOS low power dissipation. They are intended for two-way asynchronous communication between data busses. The direction of data transmission is determined by the level of the DIR input.

The enable input ( $\bar{G}$ ) can be used to disable the device so that the busses are effectively isolated.

All inputs are equipped with protection circuits against static discharge or transient excess voltage.

**FEATURES :**

- High Speed..... $t_{pd} = 10ns$ (typ.) at  $V_{CC} = 5V$
- Low Power Dissipation..... $I_{CC} = 4\mu A$ (Max.) at  $T_a = 25^\circ C$
- High Noise Immunity..... $V_{NIH} = V_{NIL} = 28\% V_{CC}$  (Min.)
- Output Drive Capability..... 15 LSTTL Loads
- Symmetrical Output Impedance...  $|I_{OH}| = I_{OL} = 6mA$ (Min.)
- Balanced Propagation Delays.....  $t_{pLH} \approx t_{pHL}$
- Wide Operating Voltage Range...  $V_{CC}$  (opr.) = 2V~6V
- Pin and Function Compatible with 74LS 245 / 640

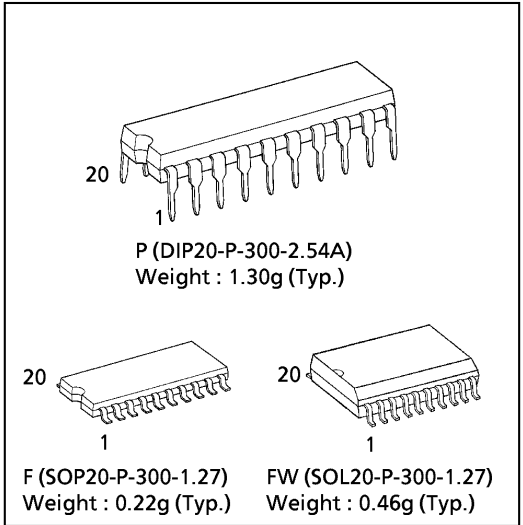

**APPLICATION NOTES**

- 1) Do not apply a signal to any bus terminal when it is in the output mode. Damage may result.
- 2) All floating ( high impedance ) bus terminals must have their input levels fixed by means of pull up or pull down resistors.

**PIN ASSIGNMENT**

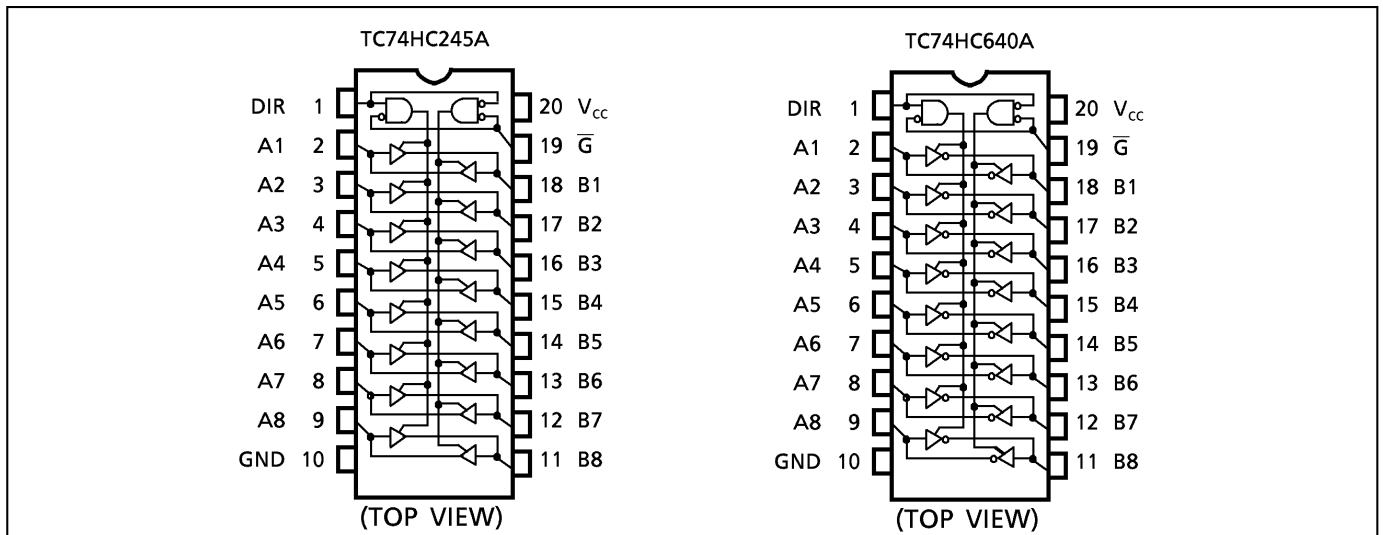

IEC LOGIC SYMBOL

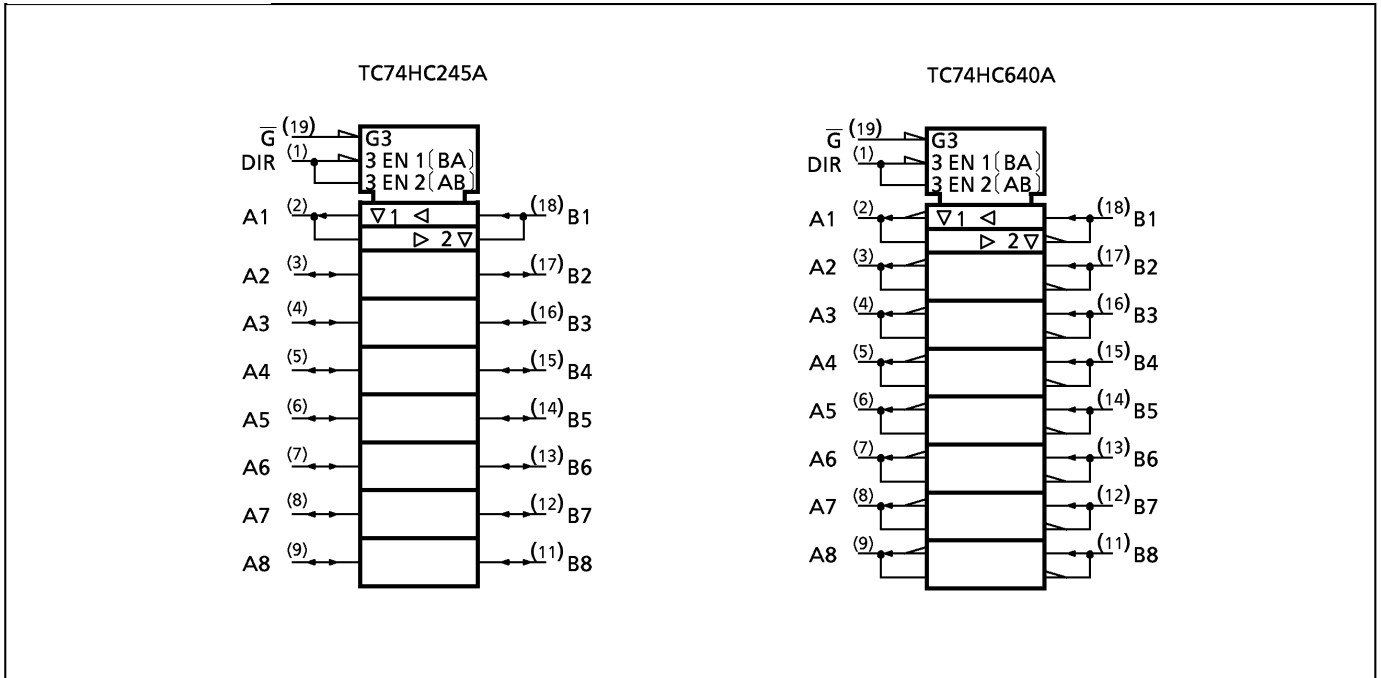

TRUTH TABLE

INPUTS		FUNCTION		OUTPUTS	
$\bar{G}$	DIR	A BUS	B BUS	HC245A	HC640A
L	L	OUTPUT	INPUT	$A = B$	$A = \bar{B}$
L	H	INPUT	OUTPUT	$B = A$	$B = \bar{A}$
H	X	High Impedance		Z	Z

X : "H" or "L"  
Z : High Impedance

## ABSOLUTE MAXIMUM RATINGS

PARAMETER	SYMBOL	VALUE	UNIT
Supply Voltage Range	$V_{CC}$	-0.5~7	V
DC Input Voltage	$V_{IN}$	-0.5~ $V_{CC} + 0.5$	V
DC Output Voltage	$V_{OUT}$	-0.5~ $V_{CC} + 0.5$	V
Input Diode Current	$I_{IK}$	±20	mA
Output Diode Current	$I_{OK}$	±20	mA
DC Output Current	$I_{OUT}$	±35	mA
DC $V_{CC}$ / Ground Current	$I_{CC}$	±75	mA
Power Dissipation	$P_D$	500 (DIP)* / 180 (SOP)	mW
Storage Temperature	$T_{stg}$	-65~150	°C

\*500mW in the range of  $T_a = -40^{\circ}\text{C} \sim 65^{\circ}\text{C}$ . From  $T_a = 65^{\circ}\text{C}$  to  $85^{\circ}\text{C}$  a derating factor of  $-10\text{mW}/^{\circ}\text{C}$  shall be applied until 300mW.

## RECOMMENDED OPERATING CONDITIONS

PARAMETER	SYMBOL	VALUE	UNIT
Supply Voltage	$V_{CC}$	2~6	V
Input Voltage	$V_{IN}$	0~ $V_{CC}$	V
Output Voltage	$V_{OUT}$	0~ $V_{CC}$	V
Operating Temperature	$T_{opr}$	-40~85	°C
Input Rise and Fall Time	$t_r, t_f$	0~1000 ( $V_{CC} = 2.0\text{V}$ ) 0~500 ( $V_{CC} = 4.5\text{V}$ ) 0~400 ( $V_{CC} = 6.0\text{V}$ )	ns

## DC ELECTRICAL CHARACTERISTICS

PARAMETER	SYMBOL	TEST CONDITION	$V_{CC}$ (V)	$T_a = 25^{\circ}\text{C}$			$T_a = -40 \sim 85^{\circ}\text{C}$		UNIT	
				MIN.	TYP.	MAX.	MIN.	MAX.		
High - Level Input Voltage	$V_{IH}$		2.0	1.50	—	—	1.50	—	V	
			4.5	3.15	—	—	3.15	—		
			6.0	4.20	—	—	4.20	—		
Low - Level Input Voltage	$V_{IL}$		2.0	—	—	0.50	—	0.50	V	
			4.5	—	—	1.35	—	1.35		
			6.0	—	—	1.80	—	1.80		
High - Level Output Voltage	$V_{OH}$	$V_{IN} = V_{IH}$ or $V_{IL}$	$I_{OH} = -20\mu\text{A}$	2.0	1.9	2.0	—	1.9	—	V
				4.5	4.4	4.5	—	4.4	—	
				6.0	5.9	6.0	—	5.9	—	
Low - Level Output Voltage	$V_{OL}$	$V_{IN} = V_{IH}$ or $V_{IL}$	$I_{OL} = 20\mu\text{A}$	2.0	—	0.0	0.1	—	0.1	V
				4.5	—	0.0	0.1	—	0.1	
				6.0	—	0.0	0.1	—	0.1	
3 - State Output Off - State Current	$I_{OZ}$	$V_{IN} = V_{IH}$ or $V_{IL}$ $V_{OUT} = V_{CC}$ or GND	6.0	—	—	±0.5	—	±5.0	$\mu\text{A}$	
Input Leakage Current	$I_{IN}$	$V_{IN} = V_{CC}$ or GND	6.0	—	—	±0.1	—	±1.0	$\mu\text{A}$	
Quiescent Supply Current	$I_{CC}$	$V_{IN} = V_{CC}$ or GND	6.0	—	—	4.0	—	40.0		

AC ELECTRICAL CHARACTERISTICS ( Input  $t_r = t_f = 6ns$  )

PARAMETER	SYMBOL	TEST CONDITION	CL (pF)	V <sub>CC</sub> (V)	Ta = 25°C			Ta = -40~85°C		UNIT
					MIN.	TYP.	MAX.	MIN.	MAX.	
Output Transition Time	$t_{TLH}$ $t_{THL}$		50	2.0	—	52	60	—	75	ns
				4.5	—	7	12	—	15	
				6.0	—	6	10	—	13	
Propagation Delay Time	$t_{pLH}$ $t_{pHL}$		50	2.0	—	33	90	—	115	
				4.5	—	12	18	—	23	
				6.0	—	10	15	—	20	
			150	2.0	—	48	120	—	150	
				4.5	—	16	24	—	30	
				6.0	—	14	20	—	26	
3 -State Output Enable time	$t_{pZL}$ $t_{pZH}$	$R_L = 1k\Omega$	50	2.0	—	48	150	—	190	
				4.5	—	16	30	—	38	
				6.0	—	14	26	—	32	
			150	2.0	—	63	180	—	225	
				4.5	—	21	36	—	45	
				6.0	—	18	31	—	38	
3 -State Output Disable time	$t_{pLZ}$ $t_{pHZ}$	$R_L = 1k\Omega$	50	2.0	—	37	150	—	190	
				4.5	—	17	30	—	38	
				6.0	—	15	26	—	32	
Input Capacitance	$C_{IN}$	DIR,G			—	5	10	—	10	pF
Bus Input Capacitance	$C_{OUT}$	An,Bn			—	13	—	—	—	
Power Dissipation Capacitance	$C_{PD}(1)$	TC74HC245A			—	39	—	—	—	
		TC74HC640A			—	37	—	—	—	

Note(1)  $C_{PD}$  is defined as the value of the internal equivalent capacitance which is calculated from the operating current consumption without load.

Average operating current can be obtained by the equation :

$$I_{CC}(\text{opr}) = C_{PD} \cdot V_{CC} \cdot f_{IN} + I_{CC} / 8 \text{ (per bit)}$$

**DIP 20PIN PACKAGE DIMENSIONS (DIP20-P-300-2.54A)**

Unit in mm



**SOP 20PIN (200mil BODY) PACKAGE DIMENSIONS (SOP20-P-300-1.27)**

Unit in mm



**SOP 20PIN (300mil BODY) PACKAGE DIMENSIONS (SOL20-P-300-1.27)**

Unit in mm

(Note) This package is not available in Japan.

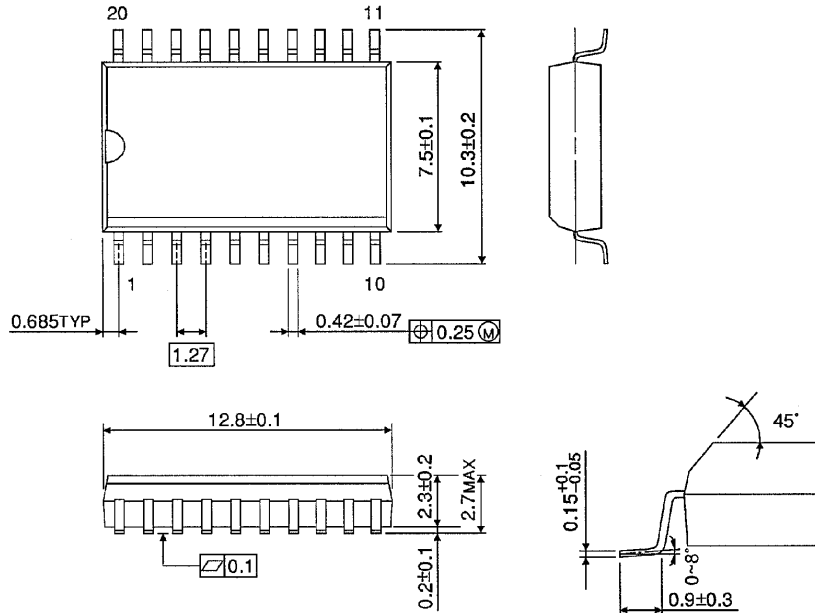

Weight : 0.46g (Typ.)

**RESTRICTIONS ON PRODUCT USE**

000707EBA

- TOSHIBA is continually working to improve the quality and reliability of its products. Nevertheless, semiconductor devices in general can malfunction or fail due to their inherent electrical sensitivity and vulnerability to physical stress. It is the responsibility of the buyer, when utilizing TOSHIBA products, to comply with the standards of safety in making a safe design for the entire system, and to avoid situations in which a malfunction or failure of such TOSHIBA products could cause loss of human life, bodily injury or damage to property. In developing your designs, please ensure that TOSHIBA products are used within specified operating ranges as set forth in the most recent TOSHIBA products specifications. Also, please keep in mind the precautions and conditions set forth in the "Handling Guide for Semiconductor Devices," or "TOSHIBA Semiconductor Reliability Handbook" etc..
- The TOSHIBA products listed in this document are intended for usage in general electronics applications (computer, personal equipment, office equipment, measuring equipment, industrial robotics, domestic appliances, etc.). These TOSHIBA products are neither intended nor warranted for usage in equipment that requires extraordinarily high quality and/or reliability or a malfunction or failure of which may cause loss of human life or bodily injury ("Unintended Usage"). Unintended Usage include atomic energy control instruments, airplane or spaceship instruments, transportation instruments, traffic signal instruments, combustion control instruments, medical instruments, all types of safety devices, etc.. Unintended Usage of TOSHIBA products listed in this document shall be made at the customer's own risk.
- The products described in this document are subject to the foreign exchange and foreign trade laws.
- The information contained herein is presented only as a guide for the applications of our products. No responsibility is assumed by TOSHIBA CORPORATION for any infringements of intellectual property or other rights of the third parties which may result from its use. No license is granted by implication or otherwise under any intellectual property or other rights of TOSHIBA CORPORATION or others.
- The information contained herein is subject to change without notice.