

FM PROCESSOR

KIA6072AF is an LSI designed for car-tuner. built in FM IF detector, noise canceller and stereo decoder on single chip, the space merit is improved. and as this has the various functions, an FM tuner with excellent characteristic can be achieved.

FUNCTIONS

FM IF Detector STAGE

- IF Limiter Amplifier
- Differential Peak FM Detector
- Meter Output
- Slider
- Radio Field Strength Muting
- Detuning Muting
- Station Detection
- IF Count Request

Noise Canceller STAGE

- Noise Detection
- Noise AGC
- Signal Delay
- Adjustment Free Pilot Cancel
- Signal Holding

MPX STAGE

- Adjustment Free PLL Stereo Decoder
- Pre-Amplifier
- Blender Control
- Tone Control (Low Cut. High Cut)
- Anti-ARI
- Anti-Birdy

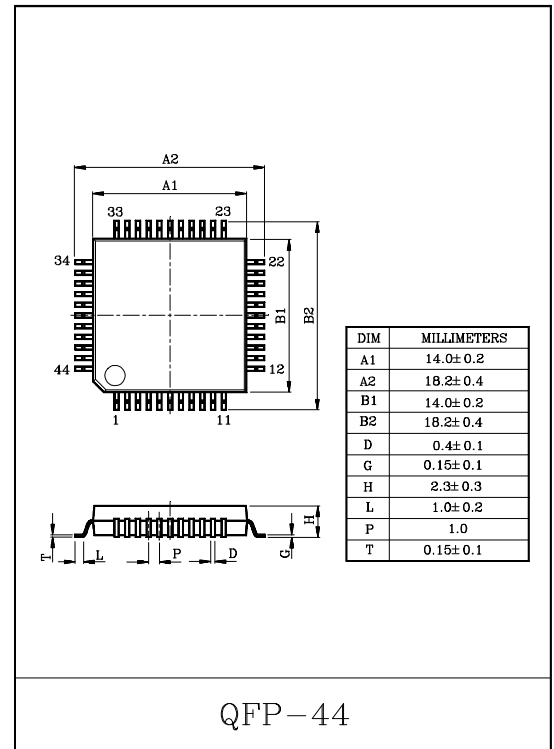

KIA6072AF

FEATURES

FM IF Detector Stage

- Application of differential peak detection is useful against multi path distortion.
- With single tuning coil, low distortion can be achieved.
: 0.2% typical at 75kHz dev.
- Good AMR performance.
: 60dB Typical at $V_{IN}=80dB\mu$
- Sensitivity and attenuation of radio field strength muting can freely be set.
- Width of detuning muting and station detector can freely be set.
- Sensitivity of station detector can freely be set.
- Station detection output can be applied to both stop pulse and IF count.
ON/OFF of IF count output can be controlled with request signal from microcomputer.
- Built-in slider which varies a position of the operating width of blender control and tone control with an inclination of meter output.

Noise Canceller Stage

- Built in Low Pass Filter for delay of pulse noise.
- Built in High Pass Filter for noise detection.
- The inclination of HPF at stereo mode is varied. and the effect of noise canceller is improved.
- For adjustment free pilot canceller, initial adjustment of pilot cancel is not necessary.

MPX Stage

- For adopting adjustment free PLL, adjustment of VCO is not necessary.
- Since tone control function which can do not only high cut but low cut at the weak radio field strength, a feeling of sound is improved.
- Anti-ARI improve the poor stereo separation caused by ARI disturbance.
- Disturbance of birdy noise etc. is improved by Anti-birdy.
- Operating supply voltage : 7~9V ($T_a=25^\circ C$)

MAXIMUM RATINGS ($T_a=25^\circ C$)

CHARACTERISTIC	SYMBOL	RATING	UNIT
Power Supply Voltage	V_{CC}	10	V
Power Dissipation (Note)	P_D	960	mW
Operating Temperature	T_{opr}	-40~85	$^\circ C$
Storage Temperature	T_{stg}	-55~150	$^\circ C$

Note : Derated linearly above $T_a=25^\circ C$ in the proportion of 8mW/ $^\circ C$. In case actual operation refer to Fig.1

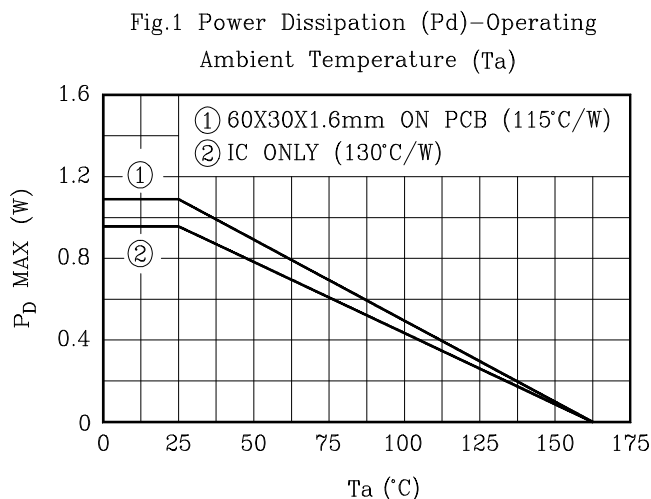

KIA6072AF

TERMINAL EXPLANATION (Terminal voltage shows typical value at quiescent signal on test circuit.
 $V_{CC}=8V$, $T_a=25^{\circ}C$)

No.	Name	Terminal Voltage	Equivalent circuit/Typical Value of external port (Internal R/C Value)	Function
1	SO	0		<ul style="list-style-type: none"> •Slider Output •Blender control or Tone control is made by this output terminal.
2	Lout	2.6		<ul style="list-style-type: none"> •MPX output •Switching circuit by a diode •low distortion by a large bias current •A capacitor value is for de-emphasis condition.
3	Rout	2.6		
4	Slide	0.7		<ul style="list-style-type: none"> •Setting terminal to vary a position of operating width for Blender/Tone control and to side an output signal rising point with an inclination of a meter output characteristic. •Connect a variable resistance. (a small sliding by resistance. with a small value.)
5	Ref3	5.2		<ul style="list-style-type: none"> •Third reference voltage. •Connect a capacitor.

KIA6072AF

No.	Name	Terminal Voltage	Equivalent circuit/Typical Value of external port (Internal R/C Value)	Function
6	IFin	3.0		<ul style="list-style-type: none"> • IF amp. Input terminal. • Connect a ceramic filter to this terminal closely. • Supply a bias to pin 11 through the resistor.
7	Bias	3.0		<ul style="list-style-type: none"> • IF Amp Bias. • Connect a capacitor.
8	By1	3.0		<ul style="list-style-type: none"> • IF Amp. Ground terminal. • Connect a ceramic filter to this pin closely.
9	G1	0		
10	Meter	0		<ul style="list-style-type: none"> • FM mode : Meter output • AM mode : Meter signal input to the internal slider circuit. voltage level of B1 is "L" • Connect a capacitor to vary a response-speed of a meter output.
11	S D	0.7		<ul style="list-style-type: none"> • Sensitivity setting terminal for the station detector. • Connect a Resistance(R_{ss}) and a capacitor(High Sensitivity by large R_{ss}. C value is for setting a response-speed)
12	SP	0		<ul style="list-style-type: none"> • Stop pulse output for station detection. • Connect a resistance to V_{DD}.
13	IFC	-		<ul style="list-style-type: none"> • IF connector output for station Detection. • A signal is output by connecting pin 13 to V_{DD} line through $R=3.3k\Omega$. No usage, open circuit or connect to the GND.
15	SM	4.8		<ul style="list-style-type: none"> • Soft muting characteristic setting terminal. (For a limiting sensitivity, noise convergent point.) • High Sensitivity by large R_{MS}, and a Capacitor is for setting a response-speed.(Ref.1)

KIA6072AF

No.	Name	Terminal Voltage	Equivalent circuit/Typical Value of external port (Internal R/C Value)	Function
14	ΔF	4.8		<ul style="list-style-type: none"> •Smoothing terminal of detector output. •Connect a capacitor •Setting a band width by a resistor value (R_{BW}).
16	Ref1	4.8		<ul style="list-style-type: none"> •Ref. 1 voltage terminal. •R_{NC} is to adjust a noise level ($V_{in}=20dB\mu$) for soft mute characteristic. Shifting the brush (for R_{NC}) in the direction of the GND is to lower a noise level (for $V_{in}=20dB\mu$). •for adjustment of FM detector is to adjust a detection coil so as to be zero in potential difference between pin 14 and pin 16.
17	G4	0		<ul style="list-style-type: none"> •Substrate GND terminal.
18	IFout	3.0		<ul style="list-style-type: none"> •Output terminal of IF limiter Amp. •A Resistor (R_{THD}) can minimize a distortion value on a set. (Detection output level is also varied by an above adjustment.)
19	Det1	3.0		<ul style="list-style-type: none"> •Differential peak Detection for conducting FM Detection. •Connect a Resistor & a capacitor. •Resistor (R_D) controls a Detection output level with a fixed Detection Band width. (Station Detection Band width is also varied by an above control.)
20	Det2	3.0		
21	B1	8		<ul style="list-style-type: none"> •Supply terminal of IF/NC stages. •VCO is Stopping in case of B1="L" level. •Connect a capacitor.

KIA6072AF

No.	Name	Terminal Voltage	Equivalent circuit/Typical Value of external port (Internal R/C Value)	Function
22	AFout	4.8		<ul style="list-style-type: none"> •Output terminal of an audio signal to be modulated by a FM IF signal. •By externally mounting R between pin 16, detection output can be reduced without changing detection bandwidth and station detecting bandwidth.
23	G2	0		<ul style="list-style-type: none"> •GND terminal for differential peak detection, reference voltage, meter, Δf, detector station detection, Muting, and Noise canceller.
24	NCin	3.0		<ul style="list-style-type: none"> •Noise canceller input. •Connect a capacitor.
25	Ref2	3.0		<ul style="list-style-type: none"> •Ref. 2 voltage terminal. •Connect a capacitor.
26	By2	3.0		<ul style="list-style-type: none"> •AGC Amp. by pass terminal for NC section. •Noise AGC high sensitivity by a small resistor value.
27	By3	2.3		<ul style="list-style-type: none"> •Noise Amp. By-pass terminal. •Connect a capacitor.

KIA6072AF

No.	Name	Terminal Voltage	Equivalent circuit/Typical Value of external port (Internal R/C Value)	Function
28	AGC	0		<ul style="list-style-type: none"> • Adjustment of a Noise AGC time constant on NC stage. • Connect a capacitor and a resistor. • Have a good effect on a Noise with a large periodicity by a large resistor value.
29	PW	0		<ul style="list-style-type: none"> • Adjustment of a Triger Pulse width on NC stage. • Connect a capacitor/resistor (A large resistor value is to widen a pulse width)
30	G3	0		•GND for MPX Stage.
31	Hold	3.8		<ul style="list-style-type: none"> • Composite signal holding terminal on NC Stage. • Connect a capacitor.
32	B2	8.0		<ul style="list-style-type: none"> • Power Supply for MPX stage • Slider circuit is operating in case of B1="L" and B2="H" (in AM mode, also the slider circuit is operating) • Connect a capacitor.
33	P	3.0		<ul style="list-style-type: none"> • Cancel signal output terminal for pilot canceller. • Connect a capacitor.

KIA6072AF

No.	Name	Terminal Voltage	Equivalent circuit/Typical Value of external port (Internal R/C Value)	Function
34	PD3	7.0		<ul style="list-style-type: none"> •Pilot detection output. •By connecting to B2(Vcc), VCO stopping and forced monaural mode are done (also receiving mode output (pin35) is done forced monaural mode at same time) •It is desirable to connect a capacitor with a lower temperature coefficient.
35	Mode	8.0		<ul style="list-style-type: none"> •Receiving mode output for Stereo /Monaural mode. •The current (around 1mA) flows into this pin by connecting the VDD through a resistor. •In case that this pin pass "L" level and there is no flowing current to this pin, this pin makes a forced monaural mode (The PLL circuit is operating)
36	PD1	7.3		<ul style="list-style-type: none"> •Phase comparator output. •Connect a capacitor and a resistor. •It is desirable to connect a capacitor with a lower temperature coefficient.
37	PD2	7.3		
38	VCO	4.2		<ul style="list-style-type: none"> •VCO oscillating terminal of nonadjusting type. •Connect the resonator (Type No. CSB456F21. MURATA MFG. Co., LTD.)

KIA6072AF

No.	Name	Terminal Voltage	Equivalent circuit/Typical Value of external port (Internal R/C Value)	Function
39	NCout	2.4		<ul style="list-style-type: none"> •NC output. •Connect a phase correction circuit to set a maximum separation characteristic.
40	MPXin	1.8		<ul style="list-style-type: none"> •MPX Pre-Amp. input for FM composite signal. •It is possible to connect this pin to other signal line by a inverter input structure (with a OP Amp circuit.)
41	LC	1.8		<ul style="list-style-type: none"> •Adjustment a cut-off frequency. •Low cut frequency adjustment by a capacitor (CL), high cut frequency adjustment by a capacitor(CH). •Low cut cancellation by a capacitor(CL) with a large capacity value. •High cut cancellation by open circuit of pin 4.
42	HC	3.4		
43	TC	3.7		<ul style="list-style-type: none"> •Tone(Low cut/High cut) control •Low cut control and High cut control are operating at same time. •Impedance should be less than 50kΩ.
44	BC	1.6		

KIA6072AF

ELECTRICAL CHARACTERISTICS

IF BLOCK

(Unless otherwise specified, VCC=8V, SW8-FM, Ta=25°C, SW1=SW2=ON, Fi(IF)=10.7MHz,
Dev.=±75kHz, fm(IF)=400Hz, Vi(IF)=80dBμ)

CHARACTERISTIC	SYMBOL	TEST CONDITION		MIN.	TYP.	MAX.	UNIT
Supply Current (FM Mode)	I _{CC1}	Vi(IF)=-20dBμ, SW1=off		30	45	55	mA
Limiting Sensitivity	Vi(lim)1			36	40	43	dBμ
Detection Output Level	Vo	0dB=450mV		-2	0	2	dB
Signal to Noise Ratio	S/N1	Dev.=±75kHz → 0kHz		65	75	-	dB
Total Harmonic Distortion	THD1	Dev.=±22.5kHz		-	-54	-46	dB
AM Rejection Ratio	AMR	Dev.=±75kHz → AM=30%, 1kHz, Vi(IF)=100dBμ		47	65	-	dB
Meter Output Level	V _{M1}	Dev.=0kHz	Vi(IF)=40dBμ	0	0.1	0.5	Vdc
	V _{M2}		Vi(IF)=60dBμ	1.0	1.5	2.0	
	V _{M3}		Vi(IF)=80dBμ	2.7	3.3	3.8	
	V _{M4}		Vi(IF)=100dBμ	4.9	5.4	6.0	
Meter Slider Output Level	V _{SO}			0.8	2.0	2.8	
Soft Muting Sensitivity	Vi(lim)2	SW2=off		43	50	58	dBμ
Soft Muting Attenuation	ATT1		Vi(IF)=80 → 0dBμ	45	55	65	dB
Detuning Muting Attenuation	ATT2	SW1=off SW2=off	fi(IF)=10.7MHz → 10.8MHz fi(IF)=10.7MHz → 10.6MHz	34	45	56	dB
Detuning Muting Band Width	BW(M)			105	130	165	kHz
Station Detection Band Width	BW(S)	Dev.=0kHz, V _{SP} =8V		43	55	73	kHz
Station Detection Sensitivity	V _{SS}	SW1=off, SW2=off		45	52	61	dBμ
IF Count Request Threshold Voltage	V _{S(IF)}		Vo(IF)=35mW	1.5	2.5	-	Vdc
IF Count Output Level	Vo(IF)		Vreq=5Vdc	150	250	-	mV

KIA6072AF

ELECTRICAL CHARACTERISTICS

NC, MPX BLOCK

(Unless otherwise specified, $V_{CC}=8V$, SW8-FM, $T_a=25^{\circ}C$, SW3=SW4=SW5=SW7=A, SW6=R, $f_i=1kHz$, $V_{i(MPX)}=360mV(Main)+40mV(pilot)$, $V_i(AM)=0$, $V_{BC}=V_{TC}=1.5V$)

CHARACTERISTIC	SYMBOL	TEST CONDITION	MIN.	TYP.	MAX.	UNIT
Gain	G_{V1}	$V_i(MPX)=400mV$ (Monaural)	-3	-1	0	dB
Channel Balance	CB	SW6=R→L	-1.0	0	1.0	dB
Max. Composite Input Level	$V_i(MAX)$	(Maom/Pilot)=9, THD=-40dB	700	1000	-	mV
Monaural THD	THD2	$V_i(MPX)=400mV$ (Monaural)	-	-60	-48	dB
Stereo THD	THD3		-	-60	-50	dB
Separation	Sep	$V_i(MPX)=360mV(Ronly)+40mV(Pilot)$ SW5=B, SW6=R→L $V_i(MPX)=360mV(Lonly)+40mV(Pilot)$ SW5=B, SW6=L→R	40	50	-	dB
Stereo S/N	S/N2	$V_i(MPX)=360mV(Main)→0$	72	80	-	dB
Stereo Signal to Residual Pilot Signal Ratio	S/N3	$V_i(MPX)=360mV(Main)→0$, SW7=B	37	46	-	dB
Signal to Residual Pulse Noise Ratio	S/N4	SW3=A→B at A $V_i(MPX)=400mV$ (Monaural) at B $V_i(NC)=100mV_{pp}$ $tw=10\mu S$, $f_i=1kHz$	70	80	-	dB
Gate Open Time	t_G	$V_i(NC)=100mV_{pp}$, $tw=10\mu S$, $f_i=1kHz$	-	33	-	μS
Pilot Sensitivity	$V_S(Pilot)$	Turned LED on	6	9	15	mV
Pilot Sensitivity Hysteresis	hy		-	1	3	dB
Stereo Operating Current	I_S	$I_S=V_S/1k$, $V_i(MPX)=360mV(Lonly)+40mV(Pilot)$ at Sep=40dB, SW4=B, SW5=B	-	0.1	0.2	mA

KIA6072AF

CHARACTERISTIC	SYMBOL	TEST CONDITION		MIN.	TYP.	MAX.	UNIT	
Baender Control Attenuation	ATT3	$V_{BC}=0.9V$	$V_i(MPX)=360mV(Sub)+40mV(Pilot)$	0	0.5	2.0	dB	
	ATT4	$V_{BC}=0.9V$		35	45	-		
Tone Control Attenuation	ATT5	$V_{TC}=0.7V$	fi=100Hz	$V_i(MPX)=400mV$ (Monaural)	0	0.5	1.8	dB
	ATT6	$V_{TC}=0.2V$			4.5	7	10.5	
	ATT7	$V_{TC}=0.7V$	fi=10kHz		0	0.5	1.8	
	ATT8	$V_{TC}=0.2V$			4	7	10	
Capture Range	CR	$V_i(MPX)=40mV(Pilot)$		-	+0.8 -1.0	-	%	
Supply Current (AM Mode)	I_{CC2}	SW8=AM	$V_i(AM)=V_i(MPX)=0$	-	20	25	mA	
Gain (AM Mode)	G_{V2}		$V_i(AM)=400mV, f=1kHz,$ $V_i(MPX)=0$	-3	-1	0	dB	

KIA6072AF

OTHER FUNCTION EXPLANATION AND APPLICATION

1. Slider application in FM mode

The slider function can slide freely a rising point of Meter output characteristic with a fixed inclination of the Meter output characteristic.

So, the Slider function can set the position of a operating midth for Blender Control(BC) and Tone Control(TC) according to a using place.

Adjusting the BC, TC with the slider function at same time, the slider function can lose a gain diviation of the Front End Stage etc...

a. In case of lengthening a BC operating area till a weak electric field.

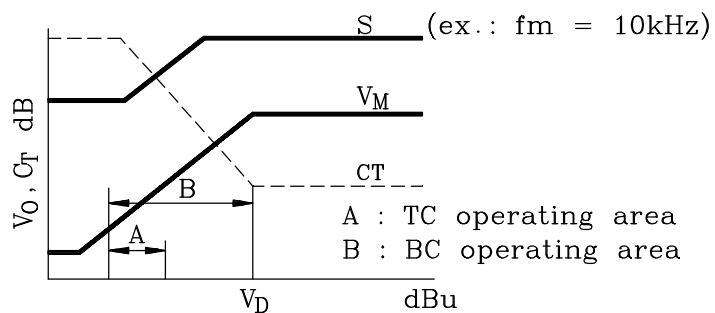
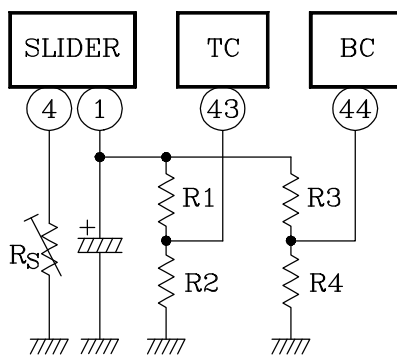

b. In case of lengthening a BC operating area till a middle electric field.

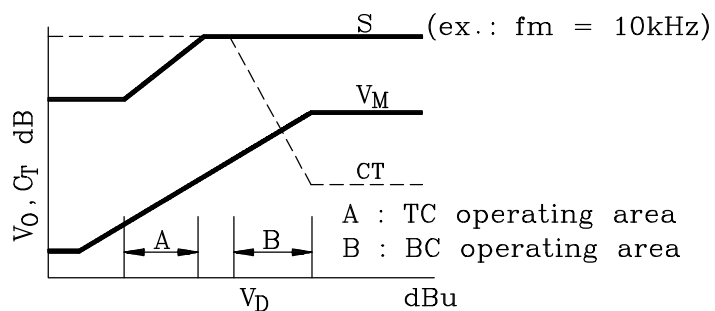
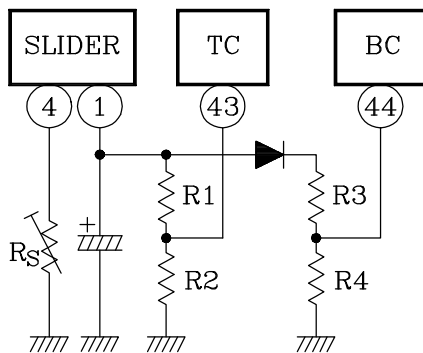

c. Note

- (1) Resistance value(in pin 1) on the parallel circuit should be about $10k\Omega$.
(for the same inclination as between slider output characteristic and meter output characteristic.)
- (2) Resistance value(in pin 43,44) on the parallel circuit should be less than $50k\Omega$
(for adjusting the BC,TC correctly)

KIA6072AF

2. HPF Frequency characteristic selection on a receiving mode at NC stage.

Selecting a frequency characteristic of HPF by stereo mode or mono mode, a detection precision of a pulse noise at each mode is improved, also a noise cancel effect is improved.

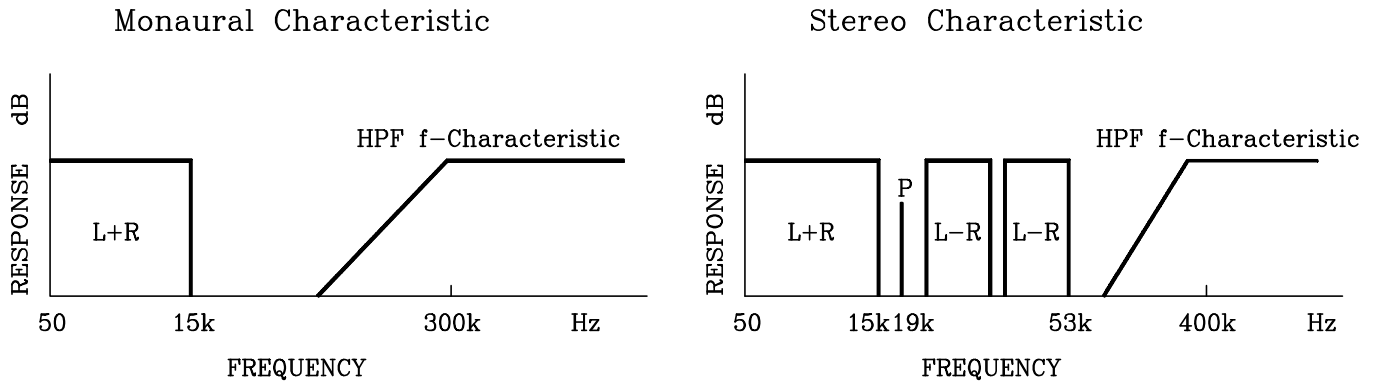

3. Auto Pilot Canceller

Building in nonadjustment type auto Pilot canceller with a negative feedback(NF). it is unnecessary a variable resistor.

4. Anti-ARI type PLL circuit

A usual PLL circuit uses a dividing signal with a square wave. As that signal has many add harmonic component, that signal is disturbed by 57kHz wave(3 times of 19kHz Pilot Signal) and side band wave (ex. ARI-SK/RDS signals)

In the KIA6072AF, as a dividing signal does not have tertiary harmonic component, that signal is not disturbed.

5. Stereo decoder circuit of Anti-Birdy.

In an usual Stereo Decoder circuit, demodulating a L/R signal by switching 38kHz square wave, a beat trouble and a of S/N lowering are occurred by and add harmonic component of 38kHz in to the stereo mode.

The KIA6072AF built in the stereo decoder circuit under no influence of a tertiary 114kHz Band, prevents a worse of S/N by an interference of adjacent channel signal and an intermodulation interference and a multipath interference.

KIA6072AF

6. Low Cut Control

The KIA6072AF builds in High Cut Control(HCC) and Low Cut Control(LCC). So, in case of a mobil-receiving a music to lengthen till a Lower/Higher frequency, and having a distributor function(1 input to 2 outputs) at MPX Stage, distribute a AM tuner demodulation output to a L/R signals and also TC is operated at same time, and S/N, practical sensitivity on a weak electric field are improved by the LCC function.

Regarding a LCC application in AM mode, it is necessary to construct an application circuit based on the above mentioned "Slider Application in FM mode".

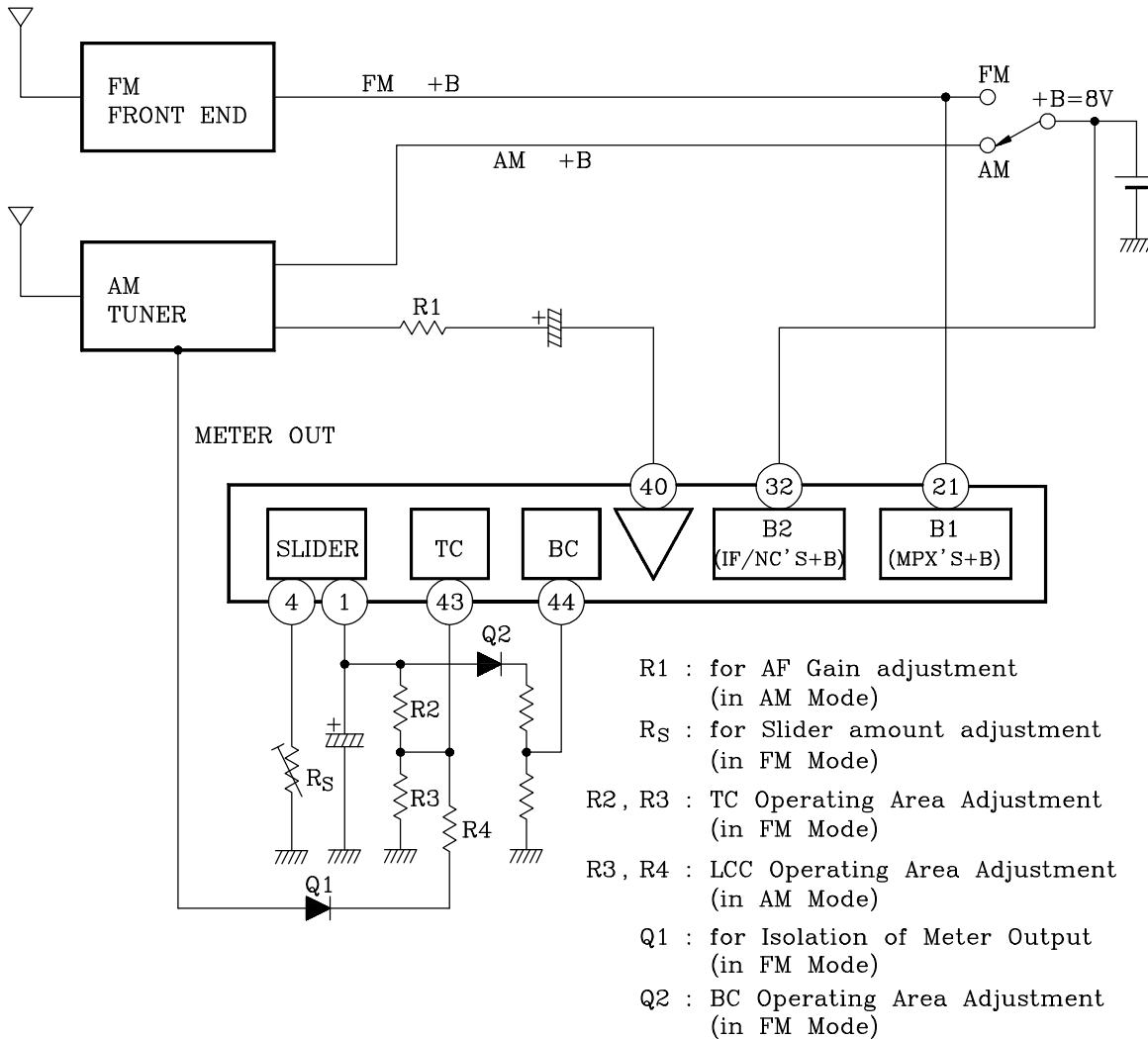

In case of B1="L" level in AM mode, use Slider input terminal (pin 10) which AM tuner output signal goes to the slider circuit (but, In case of FM mode, this pin is for meter output).

KIA6072AF

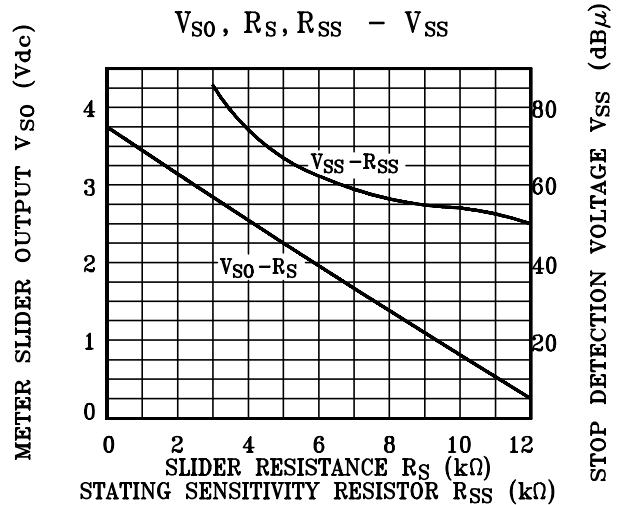
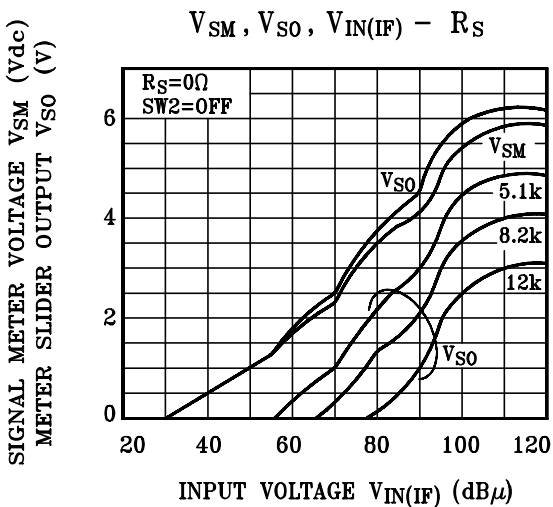
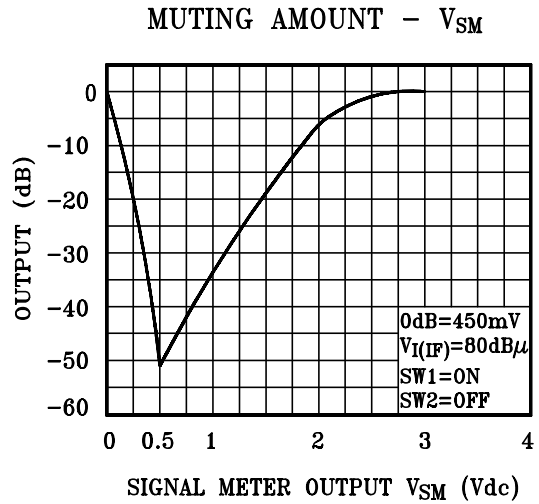
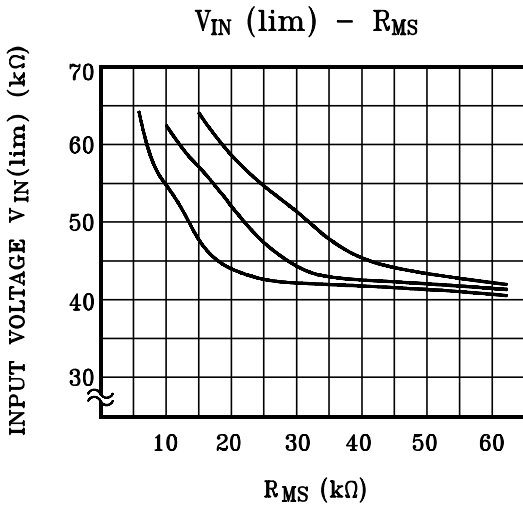
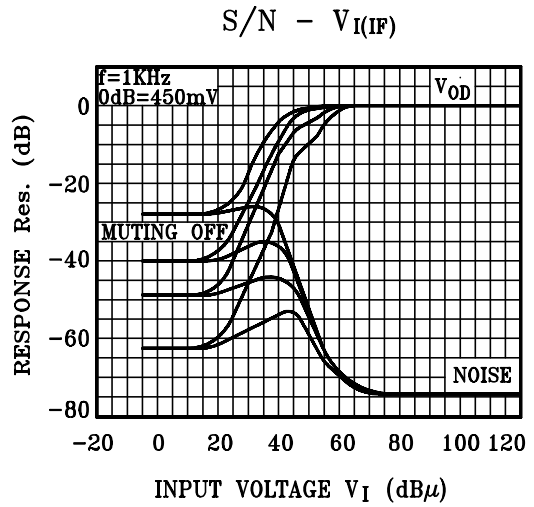
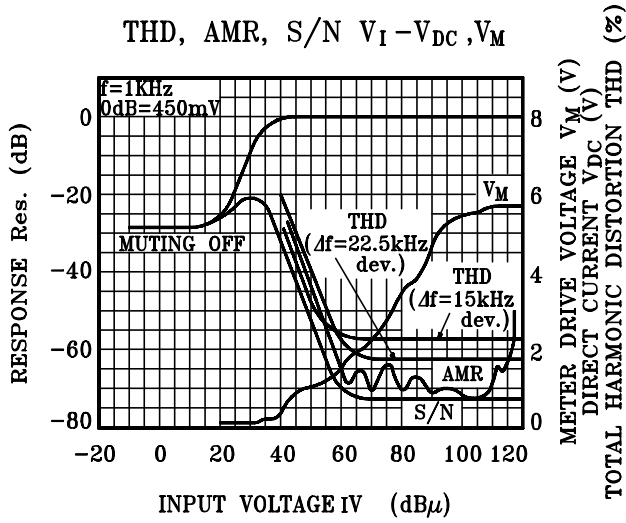

KIA6072AF

