



Document Title	HSD160PHW1-A Product Information	Page No.	1/27
Document No.	DC010-000XXX	Revision	1.0

TO :

Date : Oct., 31, 2008

HannStar Product Information **(Preliminary)**

Model: HSD160PHW1
-A**

- Note: (1) The information contained herein is tentative and may be changed without prior notices
(2) Please contact HannStar Display Corp. before designing your product based on this module specification.
(3) The information contained herein is presented merely to indicate the characteristics and performance of our products. No responsibility is assumed by HannStar for any intellectual property claims or other problems that may result from application based on the module described herein.
(4) The mark " ** " of Model means sub-model code.



Document Title	HSD160PHW1-A Product Information	Page No.	2/27
Document No.	DC010-000XXX	Revision	1.0

Record of Revisions

Rev.	Date	Sub-Model	Description of change
1.0	Oct, 31, 2008	A00	Preliminary Product Specification was first released.



Document Title	HSD160PHW1-A Product Information	Page No.	3/27
Document No.	DC010-000XXX	Revision	1.0

Contents

1.0	General description	p.4
2.0	Absolute maximum ratings.....	p.5
3.0	Optical characteristics.....	p.6
4.0	Block diagram	p.10
5.0	Interface pin connection	p.12
6.0	Electrical characteristics	p.14
7.0	Reliability test items	p.21
8.0	Outline dimension	p.22
9.0	Lot mark	p.24
10.0	Package specification	p.25
11.0	General precaution	p.26

Document Title	HSD160PHW1-A Product Information	Page No.	4/27
Document No.	DC010-000XXX	Revision	1.0

1.0 GENERAL DESCRIPTION

1.1 Introduction

HannStar Display model HSD160PHW1-A is a color active matrix thin film transistor (TFT) liquid crystal display (LCD) that uses amorphous silicon TFT as a switching device. This model is composed of a TFT LCD panel, a driving circuit and a back light system. This TFT LCD has a 16 (16:9) inch diagonally measured active display area with HD (1366 horizontal by 768 vertical pixel) resolution.

1.2 Features

- 16 (16:9 diagonal) inch configuration
- One channel LVDS interface
- 262K color by 6 bit R.G.B signal input
- RoHS Compliance
- Halogen Free

1.3 Applications

- NB

1.4 General information

Item	Specification	Unit	
Outline Dimension	365 x 214 x 5.5 (Typ.)	mm	
Display area	353.45(H) x 198.72(V)	mm	
Number of Pixel	1366 RGB (H) x 768(V)	pixels	
Pixel pitch	0.2587(H) x 0.2587(V)	mm	
Pixel arrangement	RGB Vertical stripe		
Display mode	Normally white		
NTSC	60	%	
Surface treatment	Glare, Hard-Coating (3H)		
Weight	460 (Typ.)	g	
Back-light	White LED		
Power Consumption	Logic System	(1.6) (Max.)	W
	B/L System	(5.0) (Max.)	W



Document Title	HSD160PHW1-A Product Information	Page No.	5/27
Document No.	DC010-000XXX	Revision	1.0

1.5 Mechanical Information

Item		Min.	Typ.	Max.	Unit
Module Size	Horizontal (H)	364.5	365	365.5	mm
	Vertical (V)	213.5	214	214.5	mm
	Depth (D)	—	5.5	5.8	mm
Weight		—	460	—	g

2.0 ABSOLUTE MAXIMUM RATINGS

2.1 Electrical Absolute Rating

2.1.1 TFT LCD Module

Item	Symbol	Min.	Max.	Unit	Note
Logic Supply voltage	V_{DD}	-0.3	4.0	V	

2.1.2 Environment Absolute Rating

Item	Symbol	Min.	Max.	Unit	Note
Operating Temperature	T_{opa}	0	50	°C	
Storage Temperature	T_{stg}	-20	60	°C	

Document Title	HSD160PHW1-A Product Information	Page No.	6/27
Document No.	DC010-000XXX	Revision	1.0

3.0 OPTICAL CHARACTERISTICS

3.1 Optical specification

Item		Symbol	Condition	Min.	Typ.	Max.	Unit	Note
Contrast		CR	$\Theta=0$ Normal viewing angle	—	600	—		(1)(2)(4)
Response time		RT		—	8	—	msec	(1)(3)
White luminance (5 point)		Y_L		—	220	—	cd/m ²	(1)(4)(5) ($I_L=20mA$)
Color chromaticity (CIE1931)	Red	R_x		—	(TBD)	—		
		R_y		—	(TBD)	—		
	Green	G_x		—	(TBD)	—		
		G_y		—	(TBD)	—		
	Blue	B_x		—	(TBD)	—		
		B_y		—	(TBD)	—		
	White	W_x		0.283	0.313	0.343		
		W_y	0.299	0.329	0.359			
Viewing angle	Hor.	Θ_L	CR>10	—	45	—		(1)(4)
		Θ_R		—	45	—		
	Ver.	Θ_U		—	15	—		
		Θ_D		—	35	—		
Brightness uniformity		B_{UNI}	$\Theta=0$ (5point)	80	—	—	%	(6)
Brightness Uniformity		B_{UNI}	$\Theta=0$ (13 points)	70	—	—	%	(6)

3.2 Measuring Condition

- Measuring surrounding : dark room
- LED current I_L : 20mA / signal LED
- Ambient temperature : 25±2°C
- 15min. warm-up time.

Document Title	HSD160PHW1-A Product Information	Page No.	7/27
Document No.	DC010-000XXX	Revision	1.0

3.3 Measuring Equipment

- FPM520 of Westar Display technologies, INC., which utilized SR-3 for Chromaticity and BM-5A for other optical characteristics.
- Measuring spot size : 20 ~ 21 mm

Note (1) Definition of Viewing Angle:

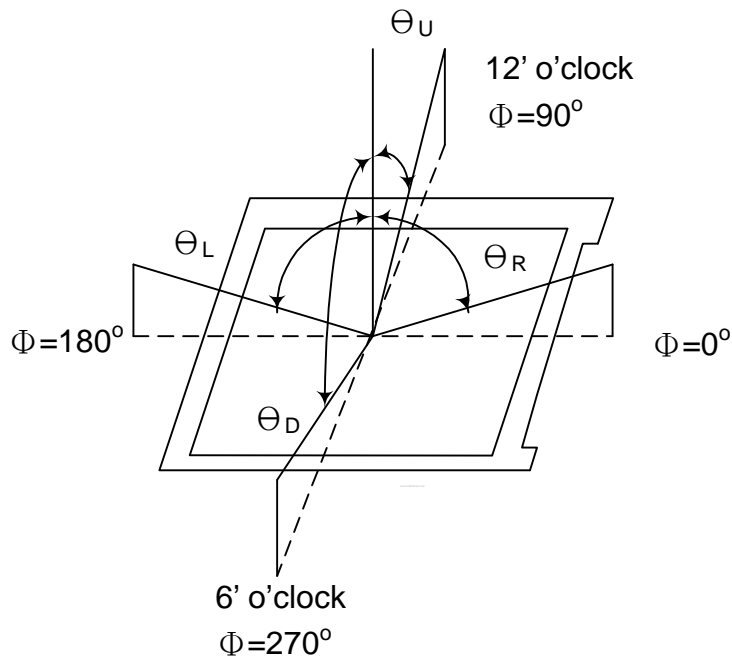

Note (2) Definition of Contrast Ratio (CR) :
measured at the center point of panel

$$CR = \frac{\text{Luminance with all pixels white}}{\text{Luminance with all pixels black}}$$

Document Title	HSD160PHW1-A Product Information	Page No.	8/27
Document No.	DC010-000XXX	Revision	1.0

Note (3) Definition of Response Time : Sum of T_R and T_F

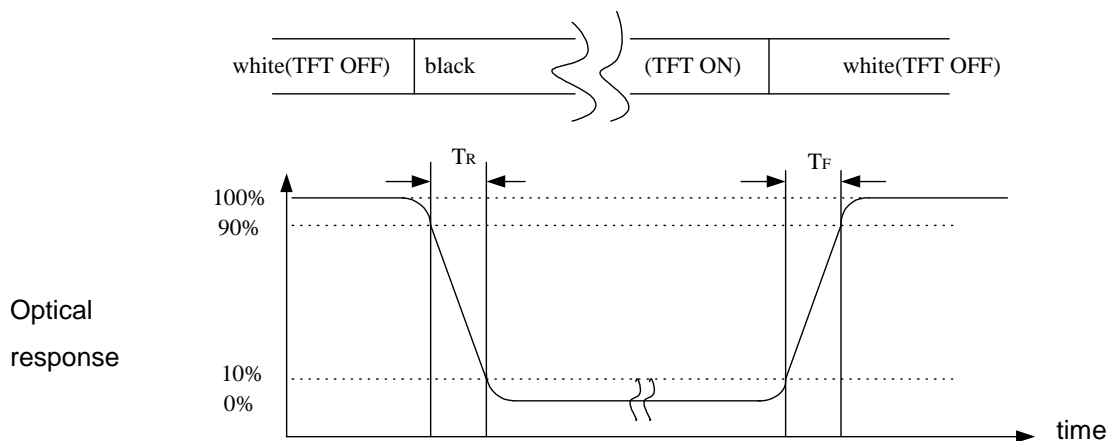

Note (4) Definition of optical measurement setup

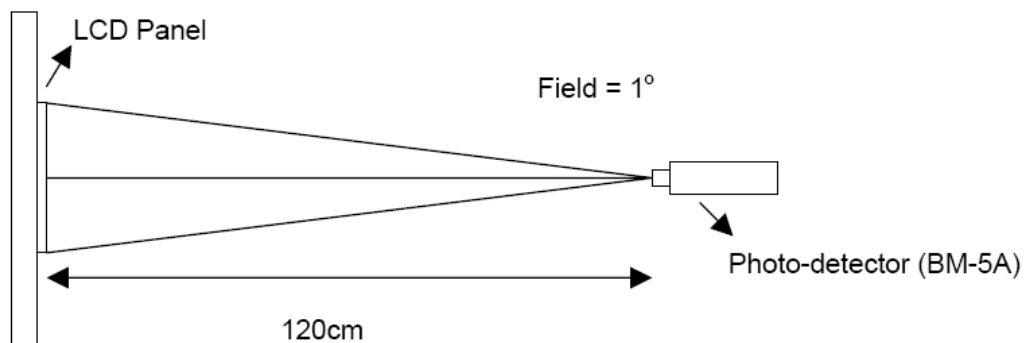

Document Title	HSD160PHW1-A Product Information	Page No.	9/27
Document No.	DC010-000XXX	Revision	1.0

Note (5) Definition of Average Luminance Uniformity of White (5 Point)

$$\text{Average Luminance Uniformity} = \frac{Y_1+Y_2+Y_3+Y_4+Y_5}{5}$$

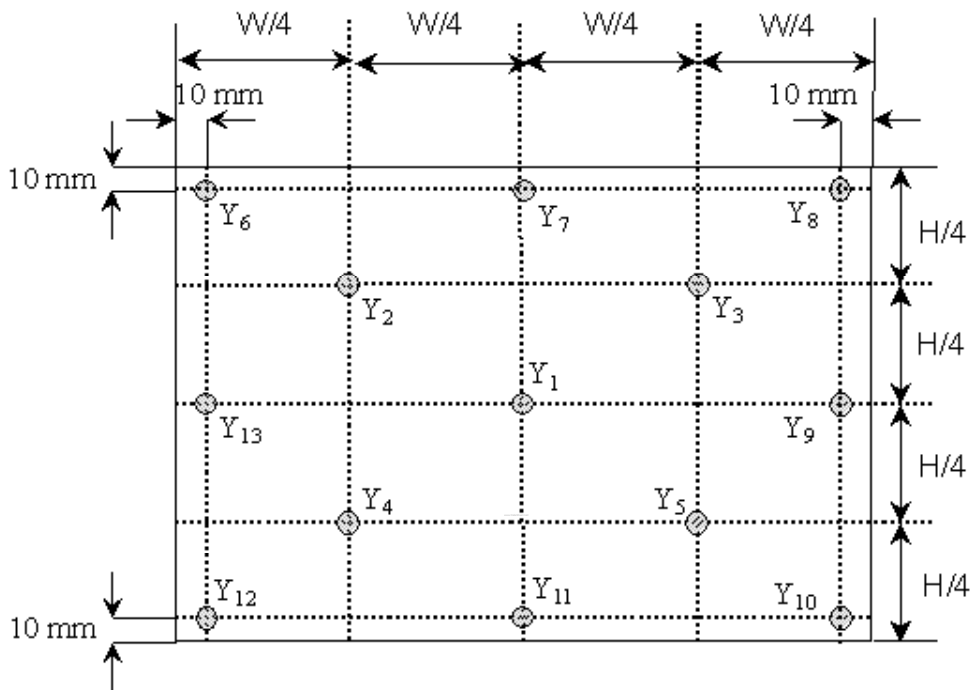

Note (6) Definition of brightness uniformity

$$\text{Luminance uniformity(5 points)} = \frac{(\text{Min Luminance of 5 points})}{(\text{Max Luminance of 5 points})} \times 100\%$$

$$\text{Luminance uniformity(13points)} = \frac{(\text{Min Luminance of 13 points})}{(\text{Max Luminance of 13 points})} \times 100\%$$

Document Title	HSD160PHW1-A Product Information	Page No.	10/27
Document No.	DC010-000XXX	Revision	1.0

4.0 BLOCK DIAGRAM

4.1 TFT LCD Module:

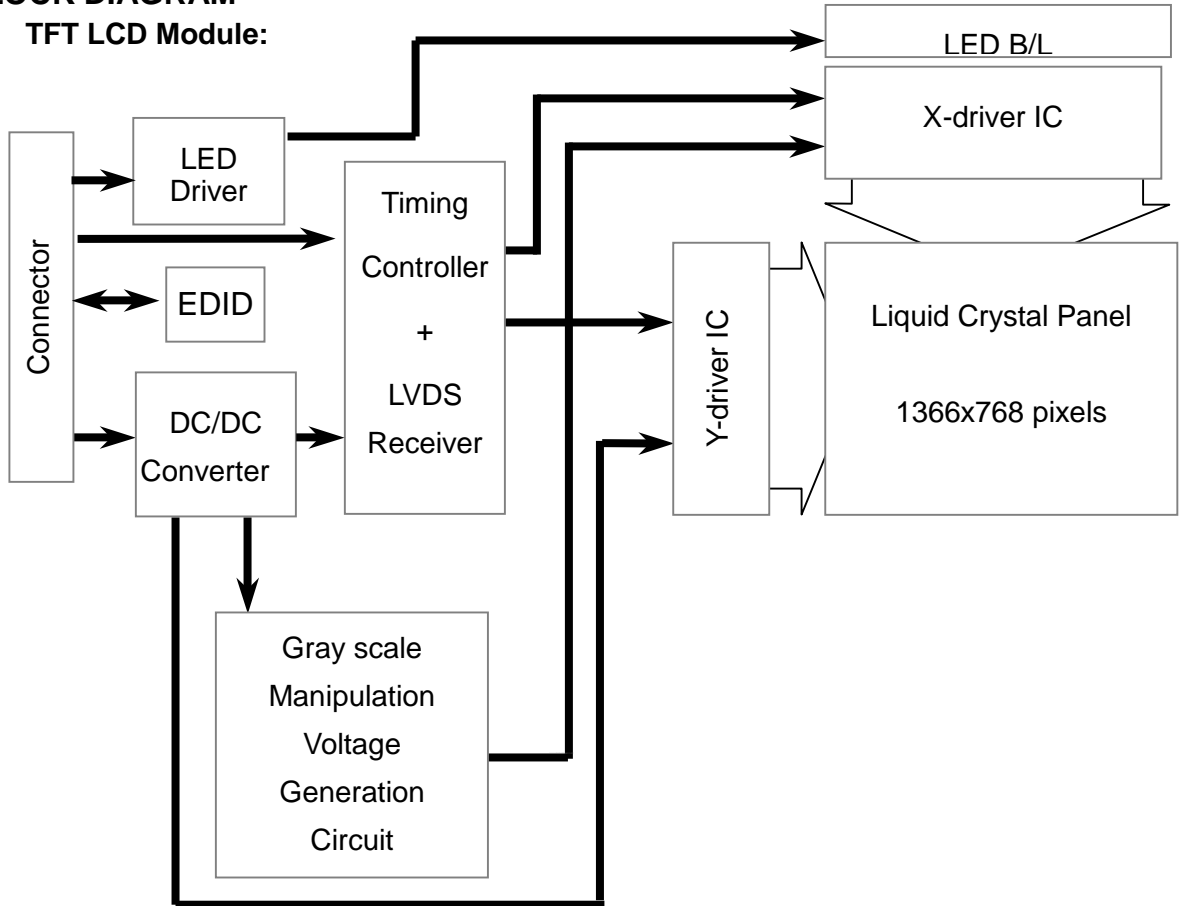

4.2 Pixel Format

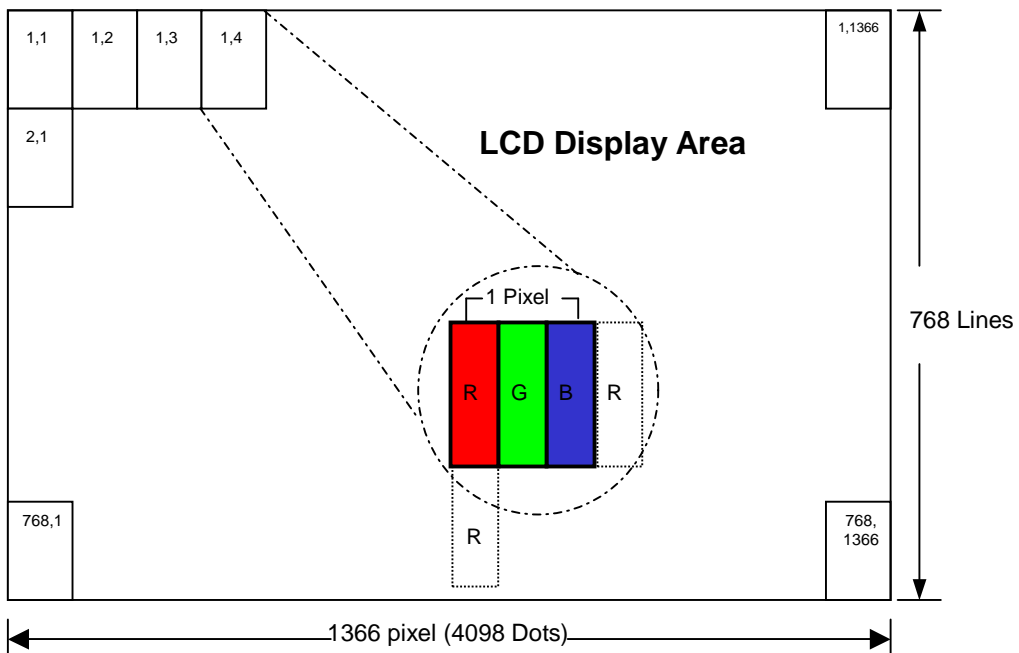

Document Title	HSD160PHW1-A Product Information	Page No.	11/27
Document No.	DC010-000XXX	Revision	1.0

4.3 Relationship Between Displayed Color and Input

	Display	MSB						LSB						Gray scale level							
		R5	R4	R3	R2	R1	R0	G5	G4	G3	G2	G1	G0		B5	B4	B3	B2	B1	B0	
Basic color	Black	L	L	L	L	L	L	L	L	L	L	L	L	L	L	L	L	L	L	-	
	Blue	L	L	L	L	L	L	L	L	L	L	L	L	H	H	H	H	H	H	-	
	Green	L	L	L	L	L	L	H	H	H	H	H	H	L	L	L	L	L	L	-	
	Light Blue	L	L	L	L	L	L	H	H	H	H	H	H	H	H	H	H	H	H	-	
	Red	H	H	H	H	H	H	L	L	L	L	L	L	L	L	L	L	L	L	-	
	Purple	H	H	H	H	H	H	L	L	L	L	L	L	H	H	H	H	H	H	-	
	Yellow	H	H	H	H	H	H	H	H	H	H	H	H	L	L	L	L	L	L	-	
	White	H	H	H	H	H	H	H	H	H	H	H	H	H	H	H	H	H	H	-	
Gray scale of Red	Black	L	L	L	L	L	L	L	L	L	L	L	L	L	L	L	L	L	L	L0	
	Dark ↑ ↓ Light	L	L	L	L	L	H	L	L	L	L	L	L	L	L	L	L	L	L	L1	
		L	L	L	L	L	L	L	L	L	L	L	L	L	L	L	L	L	L	L2	
		⋮	⋮	⋮	⋮	⋮	⋮	⋮	⋮	⋮	⋮	⋮	⋮	⋮	⋮	⋮	⋮	⋮	⋮	⋮	L3...L60
		H	H	H	H	L	H	L	L	L	L	L	L	L	L	L	L	L	L	L61	
		H	H	H	H	H	L	L	L	L	L	L	L	L	L	L	L	L	L	L62	
	Red	H	H	H	H	H	H	L	L	L	L	L	L	L	L	L	L	L	L	Red L63	
	Gray scale of Green	Black	L	L	L	L	L	L	L	L	L	L	L	L	L	L	L	L	L	L	L0
Dark ↑ ↓ Light		L	L	L	L	L	L	L	L	L	L	L	H	L	L	L	L	L	L	L1	
		L	L	L	L	L	L	L	L	L	L	L	H	L	L	L	L	L	L	L2	
		⋮	⋮	⋮	⋮	⋮	⋮	⋮	⋮	⋮	⋮	⋮	⋮	⋮	⋮	⋮	⋮	⋮	⋮	⋮	L3...L60
		L	L	L	L	L	L	H	H	H	H	L	H	L	L	L	L	L	L	L61	
		L	L	L	L	L	L	H	H	H	H	H	L	L	L	L	L	L	L	L62	
Green		L	L	L	L	L	L	H	H	H	H	H	H	L	L	L	L	L	L	Green L63	
Gray scale of Blue		Black	L	L	L	L	L	L	L	L	L	L	L	L	L	L	L	L	L	L	L0
	Dark ↑ ↓ Light	L	L	L	L	L	L	L	L	L	L	L	L	L	L	L	L	L	H	L1	
		L	L	L	L	L	L	L	L	L	L	L	L	L	L	L	L	H	L	L2	
		⋮	⋮	⋮	⋮	⋮	⋮	⋮	⋮	⋮	⋮	⋮	⋮	⋮	⋮	⋮	⋮	⋮	⋮	⋮	L3...L60
		L	L	L	L	L	L	L	L	L	L	L	L	H	H	H	H	L	H	L61	
		L	L	L	L	L	L	L	L	L	L	L	L	H	H	H	H	H	L	L62	
	Blue	L	L	L	L	L	L	L	L	L	L	L	L	H	H	H	H	H	H	Blue L63	
	Gray scale of White & Black	Black	L	L	L	L	L	L	L	L	L	L	L	L	L	L	L	L	L	L	L0
Dark ↑ ↓ Light		L	L	L	L	L	H	L	L	L	L	L	H	L	L	L	L	L	H	L1	
		L	L	L	L	L	H	L	L	L	L	H	L	L	L	L	L	H	L	L2	
		⋮	⋮	⋮	⋮	⋮	⋮	⋮	⋮	⋮	⋮	⋮	⋮	⋮	⋮	⋮	⋮	⋮	⋮	⋮	L3...L60
		H	H	H	H	L	H	H	H	H	H	L	H	H	H	H	H	L	H	L61	
		H	H	H	H	H	L	H	H	H	H	H	L	H	H	H	H	H	L	L62	
White	H	H	H	H	H	H	H	H	H	H	H	H	H	H	H	H	H	H	White L63		

Document Title	HSD160PHW1-A Product Information	Page No.	12/27
Document No.	DC010-000XXX	Revision	1.0

5.0 INTERFACE PIN CONNECTION

5.1 TFT LCD Module : CN1 (Input signal): JAE FI VHP50S-A-HF11 (JAE or equivalent)

Pin No.	Signal	Description
1	Test Loop	Test Loop(only to pin 30)
2	VEEDID	EDID 3.3V power
3	VSS	Ground (Panel logic,BL logic)
4	N/C	No connect
5	CLK EDDID	EDID clock
6	DATA EDDID	EDID data
7	N/C	No connect
8	VSS	Ground (Panel logic,BL logic)
9	Odd_Rin 0-	- LVDS differential data input (R0-R5,G0)
10	Odd_Rin 0+	LVDS differential data input (R0-R5,G1)
11	VSS1	Ground - shield LVDS Ch1
12	Odd_Rin 1-	- LVDS differential data input (G1-G5,B0-B1)
13	Odd_Rin 1+	+LVDS differential data input (G1-G5,B0-B1)
14	VSS2	Ground - shield LVDS Ch2
15	Odd_Rin 2-	- LVDS differential data input (B2-B5,HS,VS,DE)
16	Odd_Rin 2+	+LVDS differential data input (B2-B5,HS,VS,DE)
17	VSS3	Ground - shield LVDS Ch3
18	Odd_ClkIN1-	-LVDS differential clock input
19	Odd_ClkIN1+	+LVDS differential clock input
20	Test Loop	Test Loop(only to pin 1)
21	N/C	No connect
22	N/C	No connect
23	N/C	No connect
24	N/C	No connect
25	N/C	No connect
26	N/C	No connect
27	N/C	No connect
28	N/C	No connect
29	N/C	No connect
30	N/C	No connect
31	CONNTST	Connector test(The pin connect to pin 50 only)
32	VDD	Logic power 3.3V (Panel logic,BL logic)
33	VDD	Logic power 3.3V (Panel logic,BL logic)
34	Test(Bist_EN)	Panel self test
35	'+5V_ALW	
36	VSS	
37	VSS	
38	PWM_BL	PWM brightness control
39	VBL-	LED power return
40	VBL-	LED power return



Document Title	HSD160PHW1-A Product Information	Page No.	13/27
Document No.	DC010-000XXX	Revision	1.0

Pin No.	Signal	Description
41	VBL-	LED power return
42	VBL-	LED power return
43	N/C	No connect
44	VBL+	6V-20V LED Power
45	VBL+	6V-20V LED Power
46	VBL+	6V-20V LED Power
47	VBL+	6V-20V LED Power
48	SMB_DATA	SMBus Data
49	SMB_CLK	SMBus Clk
50	CONNTST	Connector test(The pin connect to pin 31 only)

Note : The brightness of LCD panel could be changed by adjusting PWM

Document Title	HSD160PHW1-A Product Information	Page No.	14/27
Document No.	DC010-000XXX	Revision	1.0

6.0 ELECTRICAL CHARACTERISTICS

6.1 TFT LCD Module

Item	Symbol	Min.	Typ.	Max.	Unit	Note
Supply Voltage	V_{DD}	3.0	3.3	3.6	V	Note (1)
Current of power supply	I_{DD}	-	0.3	-	A	$V_{DD} = 3.3V$ · L0 pattern
Inrush current	I_{RUSH}	-	-	1.50	A	Note (2)

Note (1): V_{DD} -dip condition:

When V_{DD} operating within $2.7V \leq V_{DD} < 3.0V$ · $t_d \leq 10ms$, the display may momentarily become abnormal.

$V_{DD} < 2.7V$, V_{DD} dip condition should also follow the Power On/Off conditions for supply voltage.

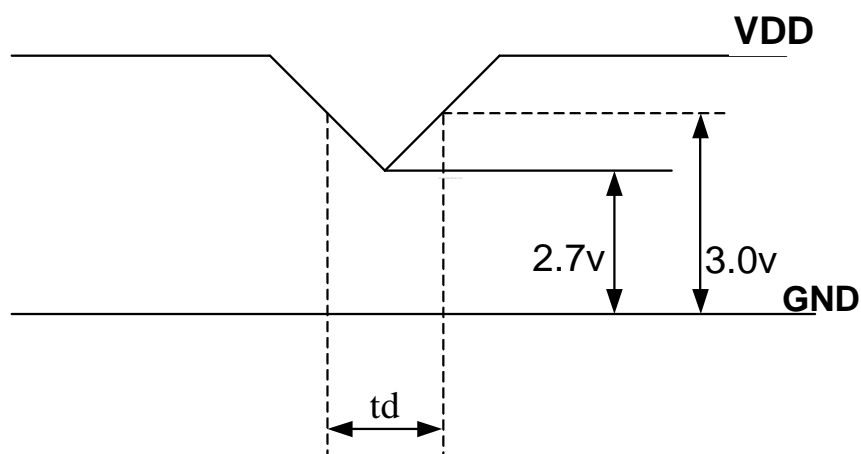

Document Title	HSD160PHW1-A Product Information	Page No.	15/27
Document No.	DC010-000XXX	Revision	1.0

Note : (2) Power on Inrush current test circuit

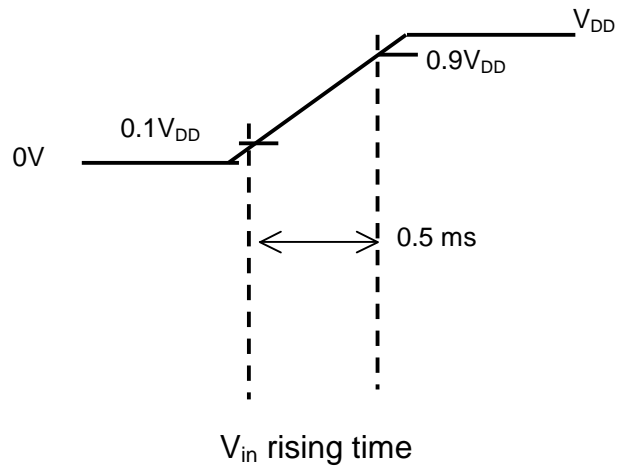
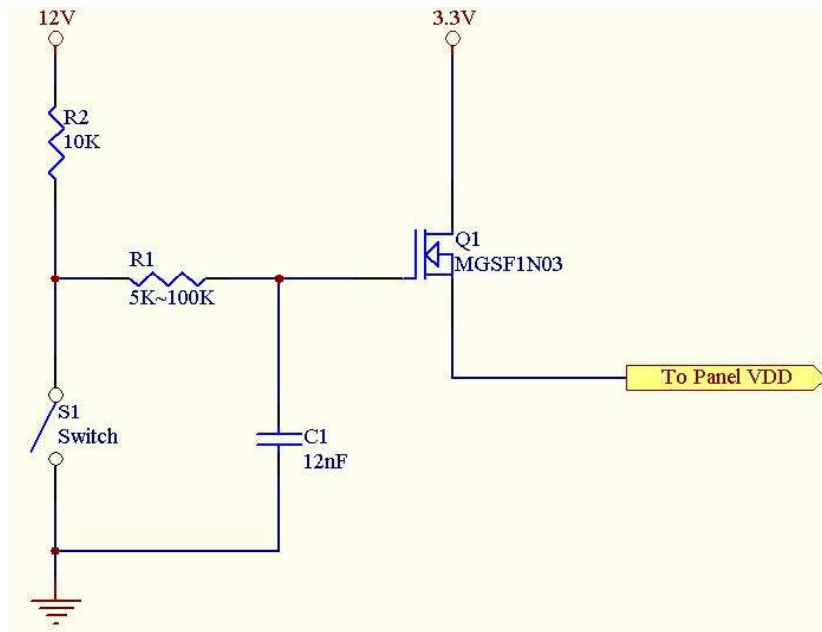

Document Title	HSD160PHW1-A Product Information	Page No.	16/27
Document No.	DC010-000XXX	Revision	1.0

6.2 Switching Characteristics for LVDS Receiver

Item	Symbol	Min.	Typ.	Max.	Unit	Conditions
Differential Input High Threshold	V _{th}	—	—	100	mV	V _{CM} =1.2V
Differential Input Low Threshold	V _{tl}	-100	—	—	mV	
Input Current	I _{IN}	-10	—	+10	uA	
Differential input Voltage	V _{ID}	0.1	—	0.6	V	
Common Mode Voltage Offset	V _{CM}	(V _{ID} /2)	1.25	1.8-0.4-(V _{ID} /2)	V	

6.3 Bit Mapping & Interface Definition

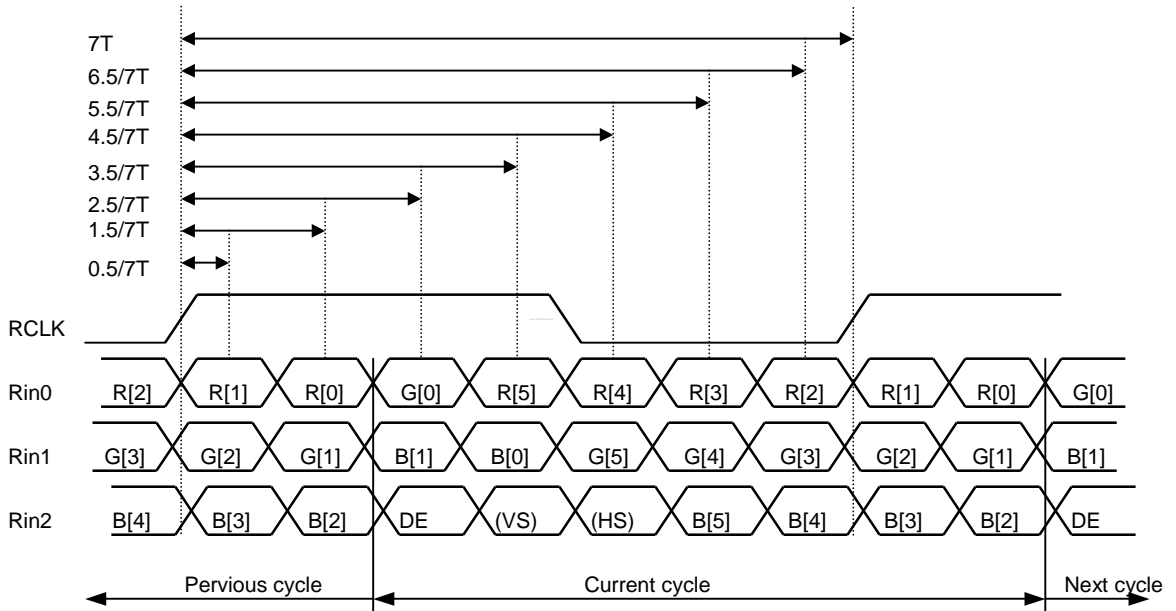

LVDS Receiver Input Timing Definition
for 6bits LVDS input

Document Title	HSD160PHW1-A Product Information	Page No.	17/27
Document No.	DC010-000XXX	Revision	1.0

6.4 Interface Timing (DE mode)

Item	Symbol	Min.	Typ.	Max.	Unit
Frame Rate	--	-	60	-	Hz
Frame Period	t1	776	808	1023	line
Vertical Display Time	t2	768	768	768	line
Vertical Blanking Time	t3	8	40	255	line
1 Line Scanning Time	t4	1396	1606	2047	clock
Horizontal Display Time	t5	1366	1366	1366	clock
Horizontal Blanking Time	t6	30	240	681	clock
Clock Rate	t7	65	72	85	MHz

Timing Diagram of Interface Signal (DE mode)

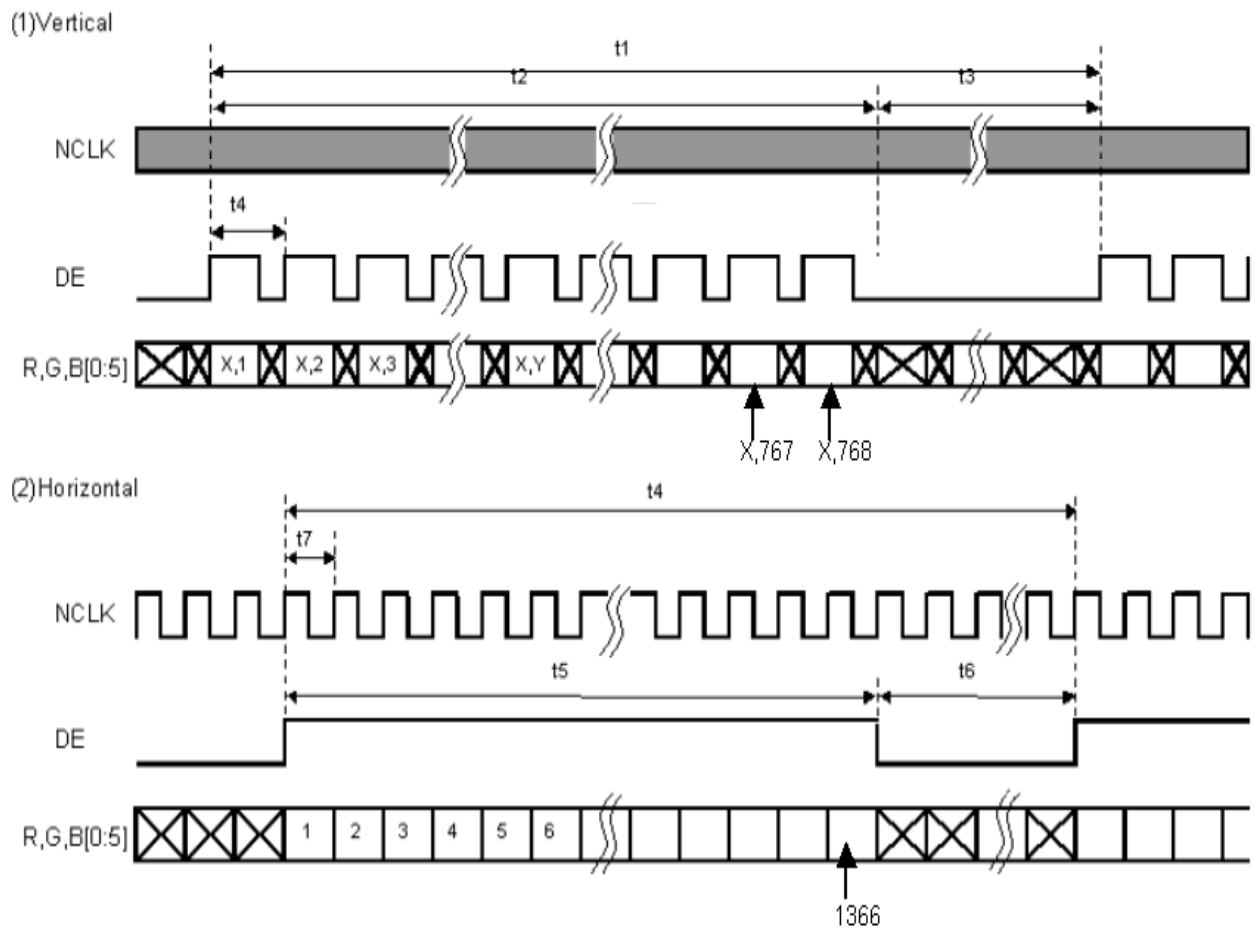

Document Title	HSD160PHW1-A Product Information	Page No.	18/27
Document No.	DC010-000XXX	Revision	1.0

6.5 Power On / Off Sequence

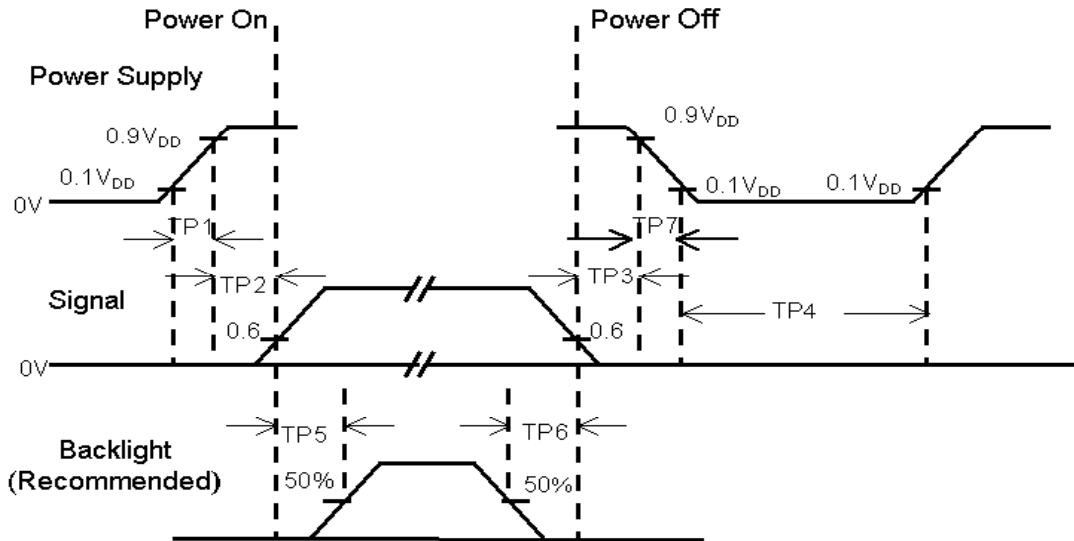

Item	Min.	Typ.	Max.	Unit	Remark
TP1	0.5	--	10	msec	
TP2	0	--	50	msec	
TP3	0	--	50	msec	
TP4	1000	--	--	msec	
TP5	200	--	--	msec	
TP6	200	--	--	msec	

Note : (1)

The

supply voltage of the external system for the module input should be the same as the definition of V_{DD}.

- (2) Apply the lamp voltage within the LCD operation range. When the back-light turns on before the LCD operation or the LCD turns off before the back-light turns off, the display may momentarily become white.
- (3) In case of V_{DD} = off level, please keep the level of input signal on the low or keep a high impedance.
- (4) TP4 should be measured after the module has been fully discharged between power off and on period.
- (5) Interface signal shall not be kept at high impedance when the power is on.

Document Title	HSD160PHW1-A Product Information	Page No.	19/27
Document No.	DC010-000XXX	Revision	1.0

6.6 Backlight Unit

Parameter	Symbol	Min	Typ	Max	Units	Condition
LED Current	I_F	--	20	21	mA	Ta=25°C
LED Voltage	V_F	3.0	3.2	3.4	Volt	Ta=25°C
LED Power consumption	P_{LED}	--	3.07	3.36	Watt	Ta=25°C Note (1)
LED Life-Time	N/A	10,000	--	--	Hour	Ta=25°C $I_F=20mA$ Note (2)

Note (1): Calculator value for reference $P=I_F \times V_F \times N$ (LED Qty')

Note (2): The LED lifetime defines as the estimated time to 50% degradation of final luminous.

6.7 LED Driver

6.7.1 Absolute Maximum Ratings

Item	Symbol	Min.	Max.	Unit	Note
LED Power Supply voltage	V_{LED}	-0.3	24	Volt	
LED_EN, PWM pin Voltage	V_{EN}, V_{PWM}	--	5.5	Volt	

6.7.2 DC Electrical Characteristics

Parameter	Symbol	Min	Typ	Max	Units
LED Power Supply Voltage	V_{LED}	7.0	--	20.0	Volt
LED_EN High Threshold	V_{ENH}	2.0	--	--	Volt
LED_EN Low Threshold	V_{ENL}	--	--	0.3	Volt
PWM High Threshold	V_{PWMH}	3.0	--	--	Volt
PWM Low Threshold	V_{PWML}	--	--	0.2	Volt
PWM Frequency	F_{PWM}	180	200	220	Hz
PWM Duty Cycle	T_D	20	--	100	%

Document Title	HSD160PHW1-A Product Information	Page No.	20/27
Document No.	DC010-000XXX	Revision	1.0

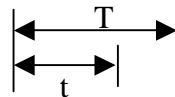
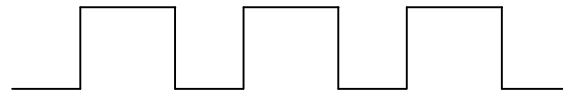

Duty Cycle $T_D = (t / T) \times 100\%$

6.7.3 LED Power on/off sequence

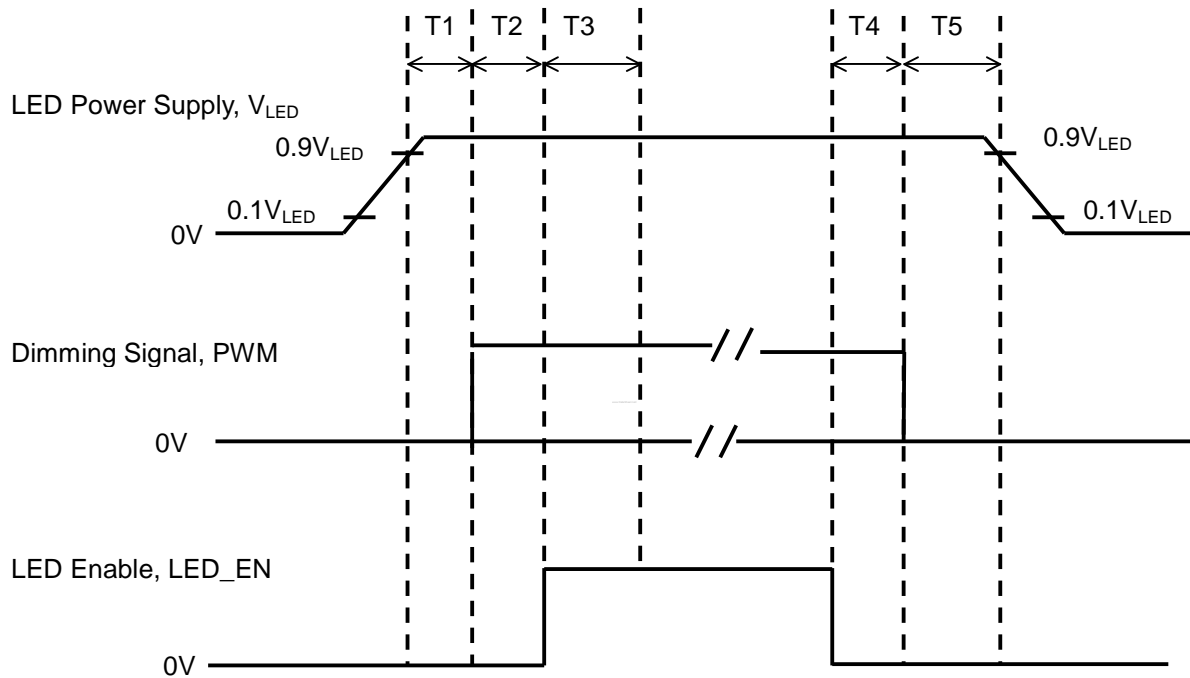

Symbol	Value			Unit
	Min	Typ	Max	
T1	10	--	--	ms
T2	10	--	--	
T3	50	--	--	
T4	0	--	--	
T5	10	--	--	

Note (1): The duty of LED dimming signal should be more than 20% in T2 and T3

Note (2): PWM can adjust brightness to control Pin. Pulse duty the bigger the brighter.

Document Title	HSD160PHW1-A Product Information	Page No.	21/27
Document No.	DC010-000XXX	Revision	1.0

7.0 Reliability test items

No.	Item	Conditions	Remark
1	High Temperature Storage	Ta=+60°C, 240hrs	
2	Low Temperature Storage	Ta=-20°C, 240hrs	
3	High Temperature Operation	Ta=+50°C, 500hrs	
4	Low Temperature Operation	Ta=0°C, 500hrs	
5	Thermal Cycling Test (non operation)	-20°C(30min)→+60°C(30min),100 cycles	
6	Vibration	Sine Wave 1.5G, 5~500Hz, XYZ 30min/each direction	
7	Shock	Half-Sine, 200G, 2ms, ±XYZ, 1time	

Storage / Operating temperature

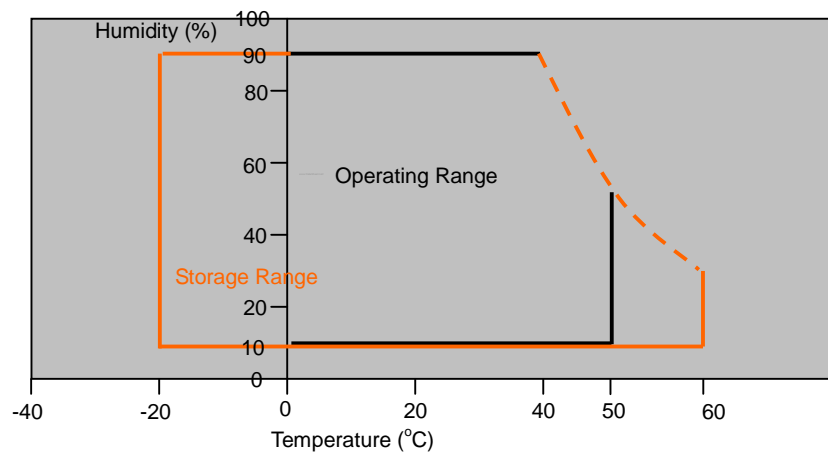

Note .Max wet bulb temp.=39°C

Document Title	HSD160PHW1-A Product Information	Page No.	22/27
Document No.	DC010-000XXX	Revision	1.0

8.0 OUTLINE DIMENSION

8.1 Front View Outline Dimension

Unit : mm

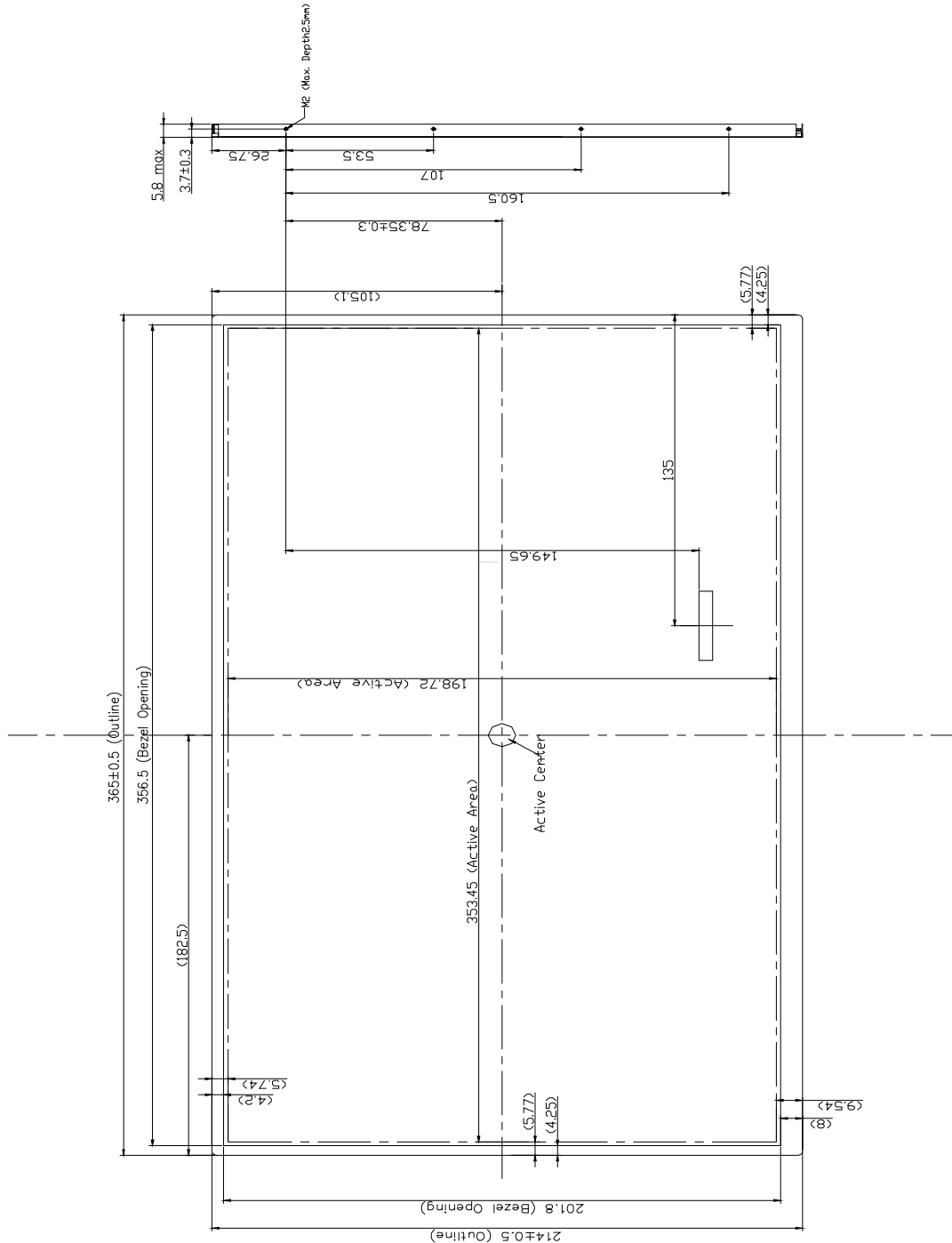

Document Title	HSD160PHW1-A Product Information	Page No.	23/27
Document No.	DC010-000XXX	Revision	1.0

8.2 Back View Outline Dimension

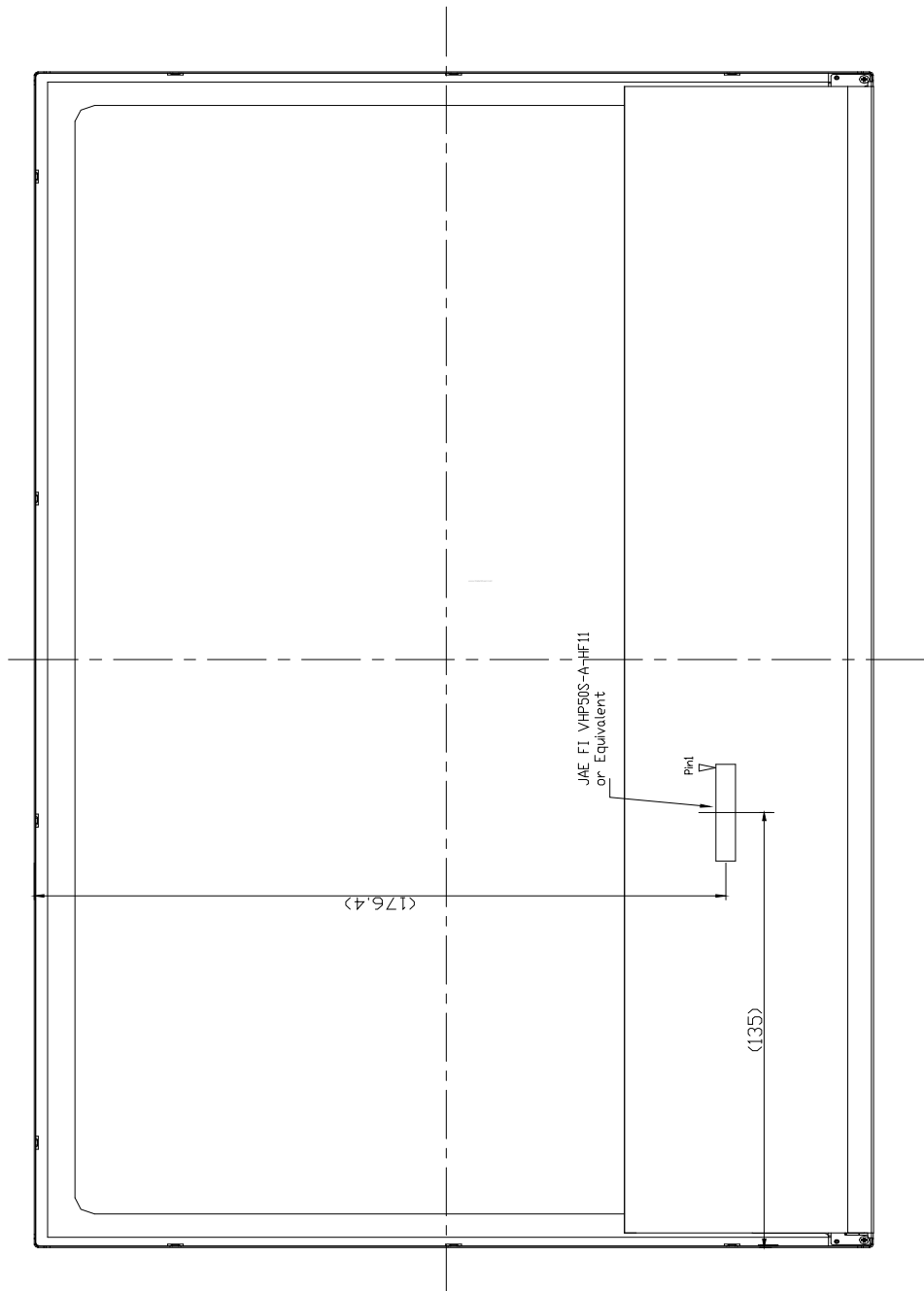

Document Title	HSD160PHW1-A Product Information	Page No.	24/27
Document No.	DC010-000XXX	Revision	1.0

9.0 LOT MARK

9.1 Lot Mark

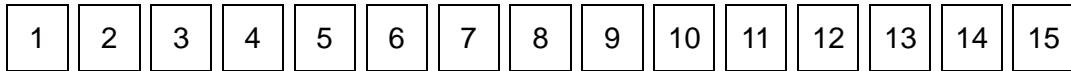

Code 1,2,3,4,5,6: HannStar internal flow control code.

Code 7: production location.

Code 8: production year.

Code 9: production month.

Code 10,11,12,13,14,15: serial number.

Note (1) Production Year

Year	1999	2000	2001	2002	2003	2004	2005	2006	2007	2008
Mark	9	0	1	2	3	4	5	6	7	8

Note (2) Production Month

Month	Jan.	Feb.	Mar.	Apr.	May.	Jun.	Jul.	Aug.	Sep.	Oct	Nov.	Dec.
Mark	1	2	3	4	5	6	7	8	9	A	B	C

9.2 Location of Lot Mark

- (1) The label is attached to the backside of the LCD module.
- (2) This is subject to change without prior notice.

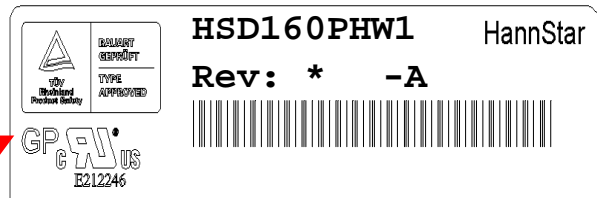
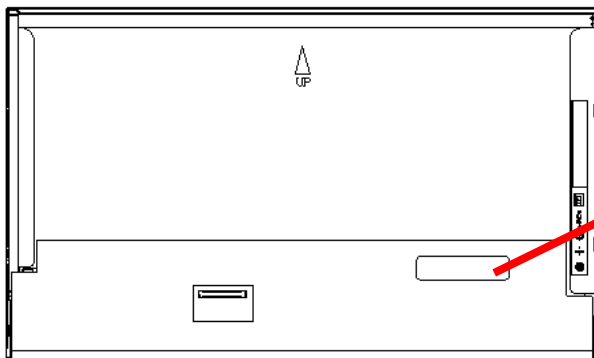



Document Title	HSD160PHW1-A Product Information	Page No.	25/27
Document No.	DC010-000XXX	Revision	1.0

10.0 PACKAGE SPECIFICATION

10.1 Packing form

- (1) Package quantity in one carton: TBD.
- (2) Carton size: TBD.

10.2 Packing assembly drawings



Document Title	HSD160PHW1-A Product Information	Page No.	26/27
Document No.	DC010-000XXX	Revision	1.0

11.0 GENERAL PRECAUTION

11.1 Use Restriction

This product is not authorized for use in life supporting systems, aircraft navigation control systems, military systems and any other application where performance failure could be life-threatening or otherwise catastrophic.

11.2 Disassembling or Modification

Do not disassemble or modify the module. It may damage sensitive parts inside LCD module, and may cause scratches or dust on the display. HannStar does not warrant the module, if customers disassemble or modify the module.

11.3 Breakage of LCD Panel

11.3.1. If LCD panel is broken and liquid crystal spills out, do not ingest or inhale liquid crystal, and do not contact liquid crystal with skin.

11.3.2. If liquid crystal contacts mouth or eyes, rinse out with water immediately.

11.3.3. If liquid crystal contacts skin or cloths, wash it off immediately with alcohol and rinse thoroughly with water.

11.3.4. Handle carefully with chips of glass that may cause injury, when the glass is broken.

11.4 Electric Shock

11.4.1. Disconnect power supply before handling LCD module.

11.4.2. Do not pull or fold the LED cable.

11.4.3. Do not touch the parts inside LCD modules and the fluorescent LED's connector or cables in order to prevent electric shock.

11.5 Absolute Maximum Ratings and Power Protection Circuit

11.5.1. Do not exceed the absolute maximum rating values, such as the supply voltage variation, input voltage variation, variation in parts' parameters, environmental temperature, etc., otherwise LCD module may be damaged.

11.5.2. Please do not leave LCD module in the environment of high humidity and high temperature for a long time.

11.5.3. It's recommended to employ protection circuit for power supply.

11.6 Operation

11.6.1 Do not touch, push or rub the polarizer with anything harder than HB pencil lead.

11.6.2 Use fingerstalls of soft gloves in order to keep clean display quality, when persons handle the LCD module for incoming inspection or assembly.

11.6.3 When the surface is dusty, please wipe gently with absorbent cotton or other soft material.

Document Title	HSD160PHW1-A Product Information	Page No.	27/27
Document No.	DC010-000XXX	Revision	1.0

11.6.4 Wipe off saliva or water drops as soon as possible. If saliva or water drops contact with polarizer for a long time, they may causes deformation or color fading.

11.6.5 When cleaning the adhesives, please use absorbent cotton wetted with a little petroleum benzine or other adequate solvent.

11.7 Mechanism

Please mount LCD module by using mounting holes arranged in four corners tightly.

11.8 Static Electricity

11.8.1 Protection film must remove very slowly from the surface of LCD module to prevent from electrostatic occurrence.

11.8.2 Because LCD module use CMOS-IC on circuit board and TFT-LCD panel, it is very weak to electrostatic discharge. Please be careful with electrostatic discharge. Persons who handle the module should be grounded through adequate methods.

11.9 Strong Light Exposure

The module shall not be exposed under strong light such as direct sunlight. Otherwise, display characteristics may be changed.

11.10 Disposal

When disposing LCD module, obey the local environmental regulations.