



STEVAL-IHM025V1

1 kW 3-phase motor control demonstration board featuring the IGBT SLLIMM™ STGIPL14K60

Data brief

Features

- Min. input voltage: 125 VDC or 90 VAC
- Max. input voltage: 400 VDC or 285 VAC
- Max. output power for motors up to 1000 W
- Regenerative STEVAL-IHM025V1 brake control feature
- Input inrush limitation with bypassing relay
- +15 V auxiliary power supply based on buck converter with VIPer16
- Uses IGBT intelligent power module STGIPL14K60 in SDIP 38L molded package
- Fully populated board conception with test points and isolated plastic safety cover
- Motor control connector for interface with STM3210B-EVAL board and other ST motor control-dedicated kits
- Tachometer input
- Hall/encoder inputs
- Possibility to connect a BEMF daughterboard for sensorless six-step control
- RoHS compliant

Description

The STEVAL-IHM025V1 demonstration board is an AC/DC inverter that generates a three-phase waveform for driving three or two-phase motors such as induction motors or PMSM motors up to 1000 W, with or without sensors.

The system represents a universal, fully-evaluated and populated design consisting of a 3-phase inverter bridge based on the 600 V IGBT SLLIMM™ (small low-loss intelligent molded module) in the SDIP 38L package mounted on a heatsink. The STGIPL14K60 integrates: high voltage, short-circuit rugged IGBT, and high voltage gate drivers with advanced features like integrated op amp suitable for advanced current sensing. Thanks to this integrated module, the



system has been specifically designed to achieve power inversion in a reliable and compact design. The system architecture of the module is based on integrated advanced features and is specifically designed to achieve fast and accurate conditioning of the current feedback, thereby matching the typical requirements in field-oriented control (FOC).

The board is designed to be compatible with single-phase mains, supplying from 90 VAC to 285 VAC or from 125 VDC up to 400 VDC for DC voltage.

Figure 2. Circuit schematic (2 of 5)

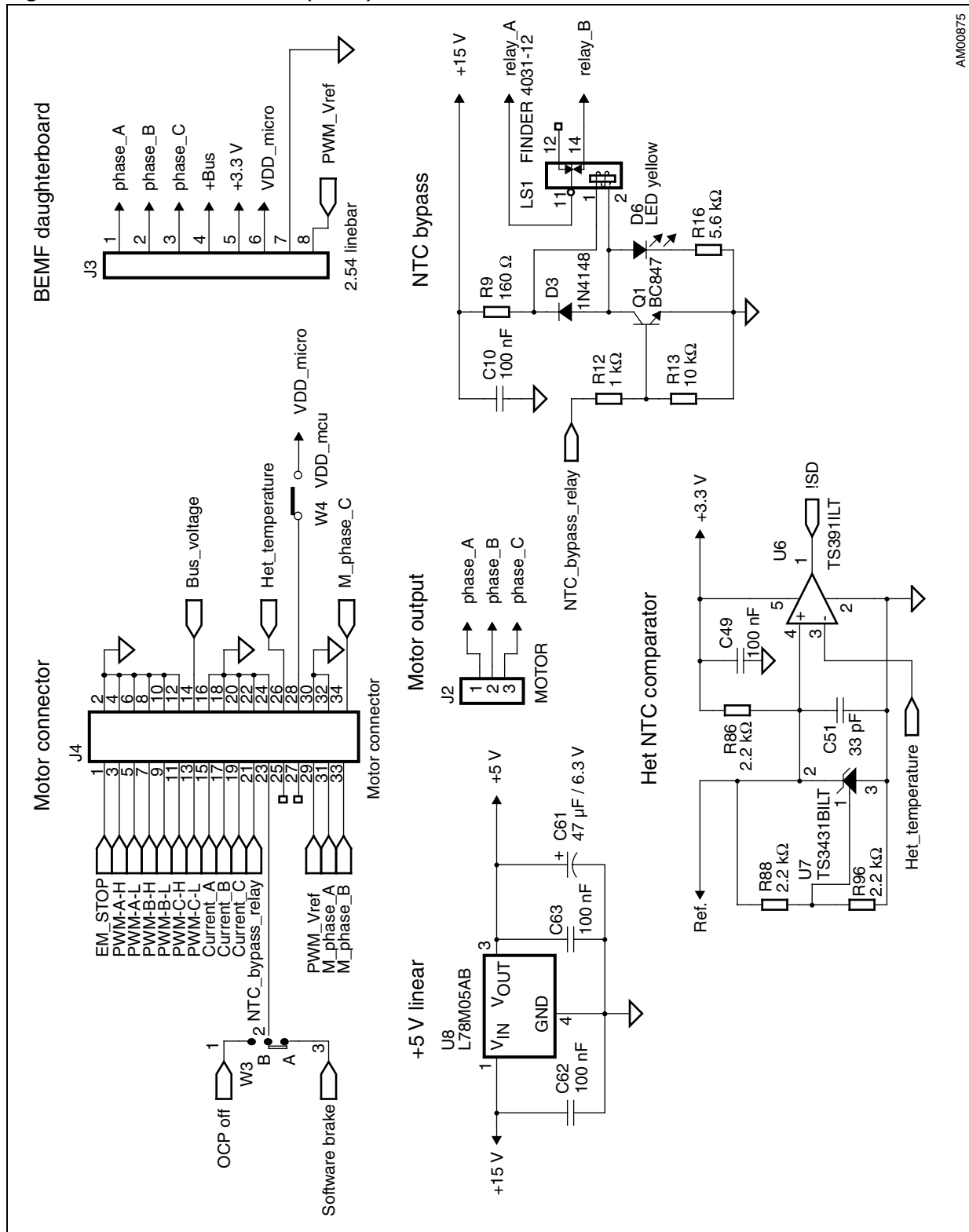

AM00875

Figure 3. Circuit schematic (3 of 5)

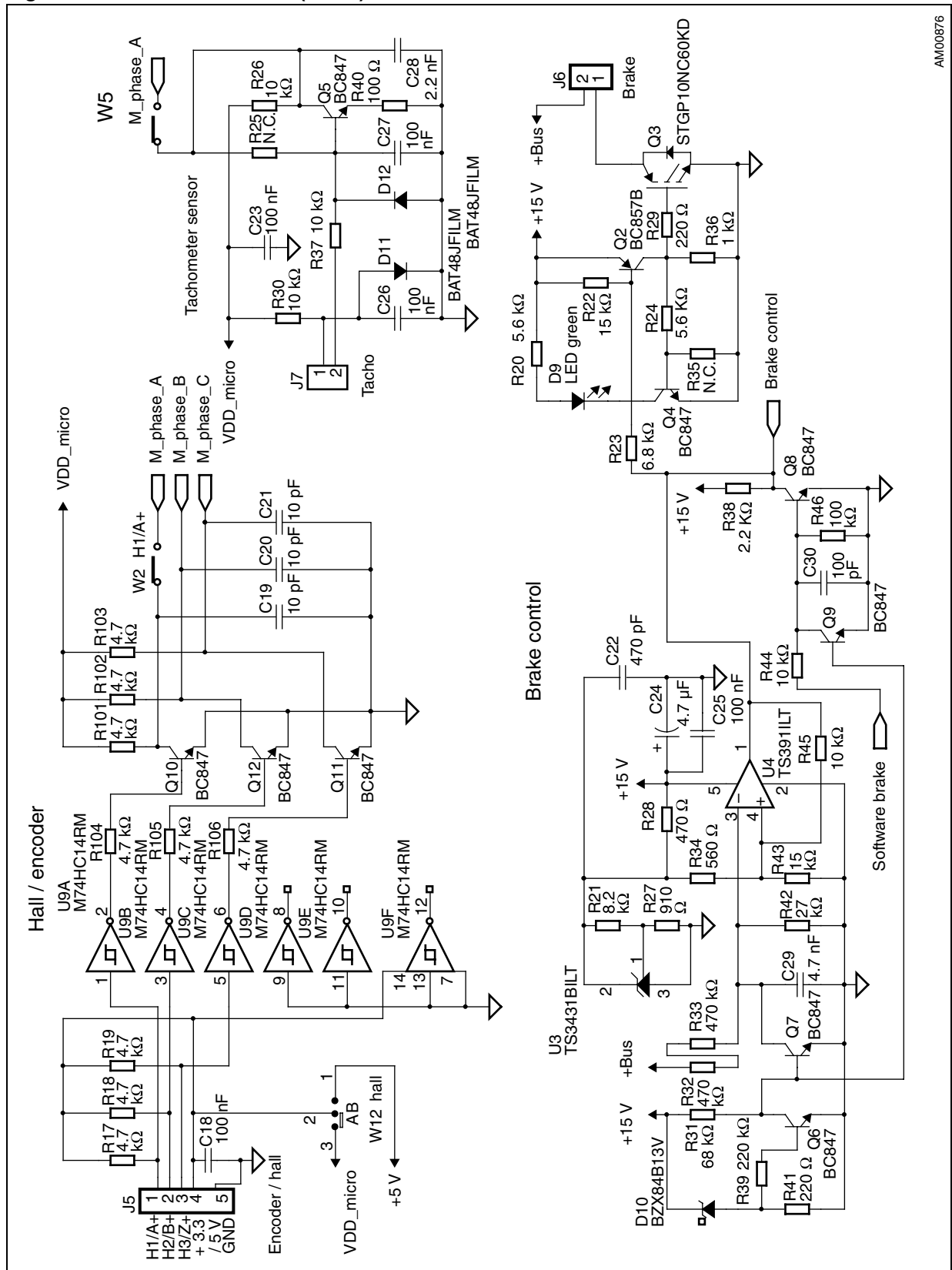

AM00876



Figure 4. Circuit schematic (4 of 5)

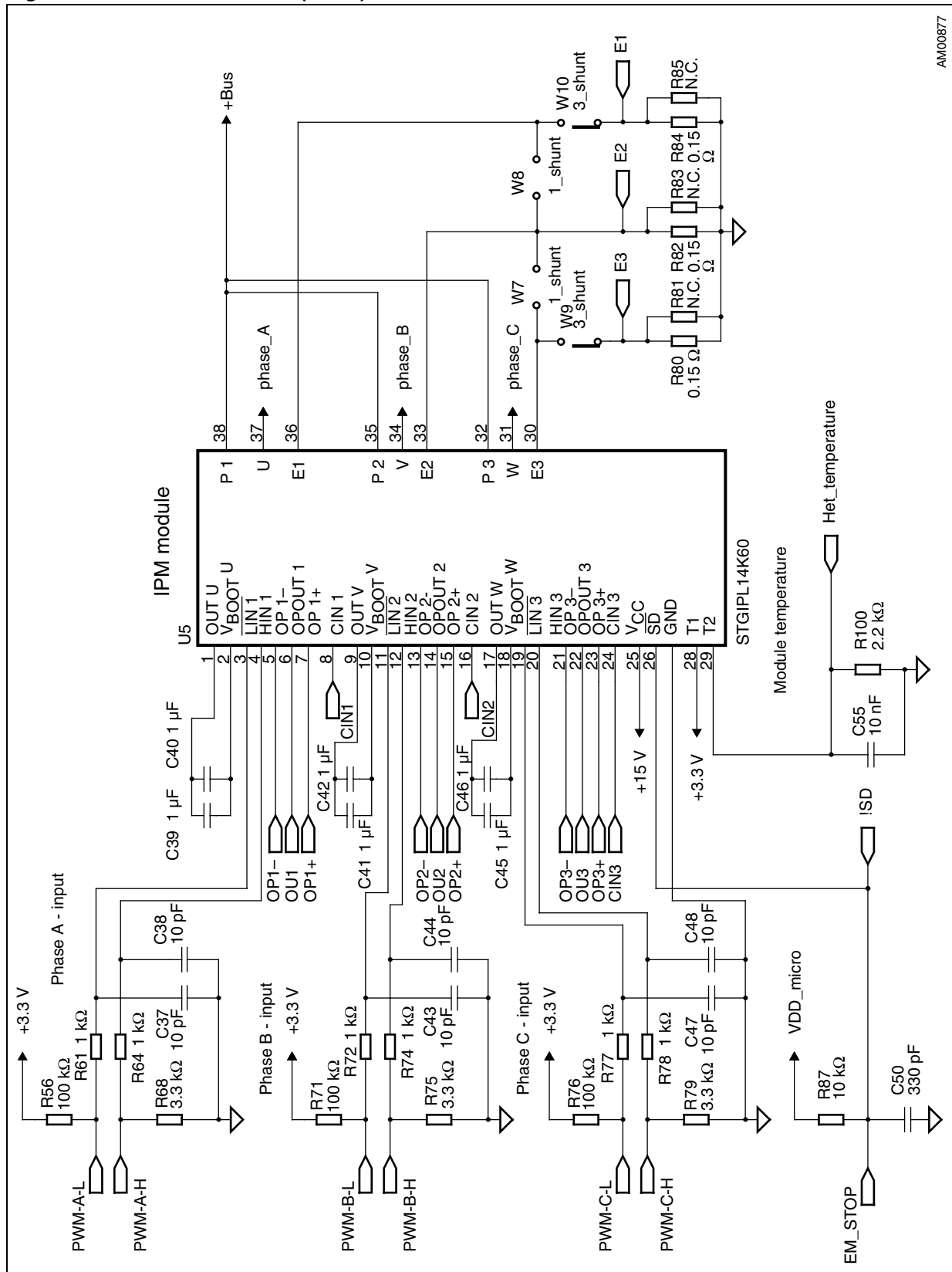
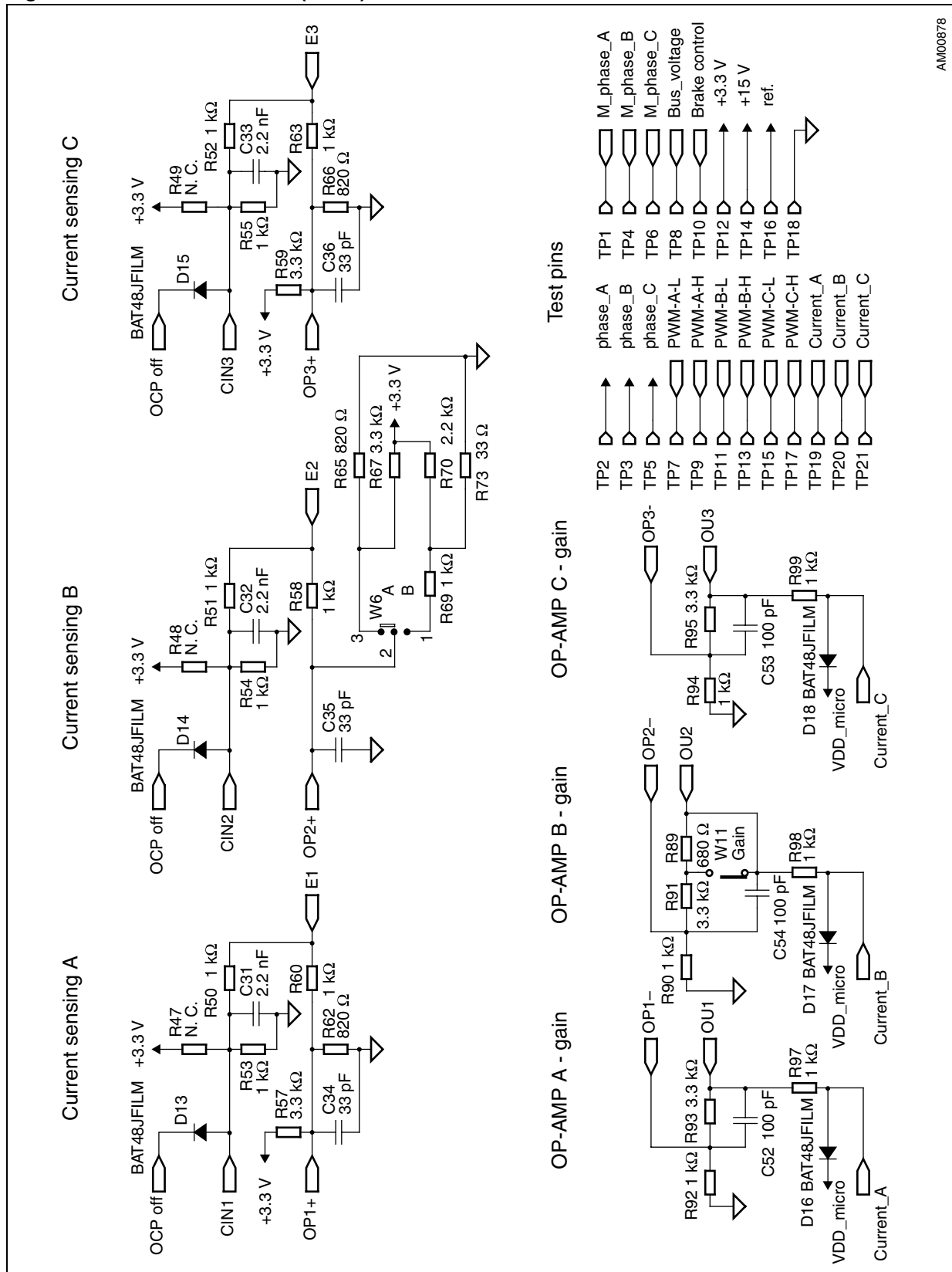

Figure 5. Circuit schematic (5 of 5)



AM00878

2 Revision history

Table 1. Document revision history

Date	Revision	Changes
16-Jun-2010	1	Initial release.
08-Apr-2011	2	Updated description in cover page.
26-Apr-2011	3	Content reworked to improve readability, no technical changes.

Please Read Carefully:

Information in this document is provided solely in connection with ST products. STMicroelectronics NV and its subsidiaries ("ST") reserve the right to make changes, corrections, modifications or improvements, to this document, and the products and services described herein at any time, without notice.

All ST products are sold pursuant to ST's terms and conditions of sale.

Purchasers are solely responsible for the choice, selection and use of the ST products and services described herein, and ST assumes no liability whatsoever relating to the choice, selection or use of the ST products and services described herein.

No license, express or implied, by estoppel or otherwise, to any intellectual property rights is granted under this document. If any part of this document refers to any third party products or services it shall not be deemed a license grant by ST for the use of such third party products or services, or any intellectual property contained therein or considered as a warranty covering the use in any manner whatsoever of such third party products or services or any intellectual property contained therein.

UNLESS OTHERWISE SET FORTH IN ST'S TERMS AND CONDITIONS OF SALE ST DISCLAIMS ANY EXPRESS OR IMPLIED WARRANTY WITH RESPECT TO THE USE AND/OR SALE OF ST PRODUCTS INCLUDING WITHOUT LIMITATION IMPLIED WARRANTIES OF MERCHANTABILITY, FITNESS FOR A PARTICULAR PURPOSE (AND THEIR EQUIVALENTS UNDER THE LAWS OF ANY JURISDICTION), OR INFRINGEMENT OF ANY PATENT, COPYRIGHT OR OTHER INTELLECTUAL PROPERTY RIGHT.

UNLESS EXPRESSLY APPROVED IN WRITING BY AN AUTHORIZED ST REPRESENTATIVE, ST PRODUCTS ARE NOT RECOMMENDED, AUTHORIZED OR WARRANTED FOR USE IN MILITARY, AIR CRAFT, SPACE, LIFE SAVING, OR LIFE SUSTAINING APPLICATIONS, NOR IN PRODUCTS OR SYSTEMS WHERE FAILURE OR MALFUNCTION MAY RESULT IN PERSONAL INJURY, DEATH, OR SEVERE PROPERTY OR ENVIRONMENTAL DAMAGE. ST PRODUCTS WHICH ARE NOT SPECIFIED AS "AUTOMOTIVE GRADE" MAY ONLY BE USED IN AUTOMOTIVE APPLICATIONS AT USER'S OWN RISK.

Resale of ST products with provisions different from the statements and/or technical features set forth in this document shall immediately void any warranty granted by ST for the ST product or service described herein and shall not create or extend in any manner whatsoever, any liability of ST.

ST and the ST logo are trademarks or registered trademarks of ST in various countries.

Information in this document supersedes and replaces all information previously supplied.

The ST logo is a registered trademark of STMicroelectronics. All other names are the property of their respective owners.

© 2011 STMicroelectronics - All rights reserved

STMicroelectronics group of companies

Australia - Belgium - Brazil - Canada - China - Czech Republic - Finland - France - Germany - Hong Kong - India - Israel - Italy - Japan - Malaysia - Malta - Morocco - Philippines - Singapore - Spain - Sweden - Switzerland - United Kingdom - United States of America

www.st.com