

CR 52 SG

Features

- Solid State Ceramic Chip
- High Power Thermal Absorption
- Superior Light Uniformity Over 180°
- End-to-End and Side-to-Side Stackable to a pitch of 1.3mm
- Solderpads conform to Mil-Std 883B
- Uniform Brightness
- Green Diffused Lens



Applications

- Ideal For Back-Light Applications
- Custom Configurations

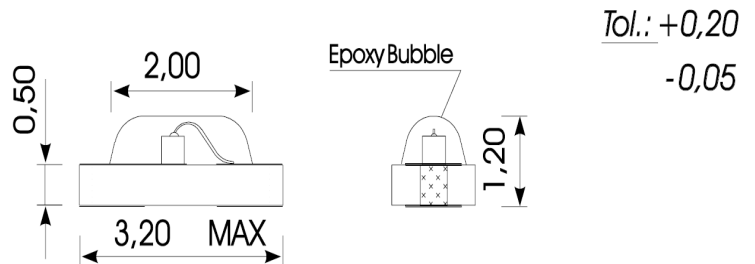

Maximum Ratings (Ta=25°C)

Characteristic	Symbol	Max.	Unit
Forward Current	I _F	75	mA
Reverse Voltage	V _R	60	V
Power Dissipation	P _D	130.00	mW
Operating Temperature	T _{opr}	-25 ~ +80	°C
Storage Temperature	T _{stg}	-25 ~ +120	°C
Soldering Temperature	T _{sol}	250	°C
Soldering Time	-	for 10 sec. max	-

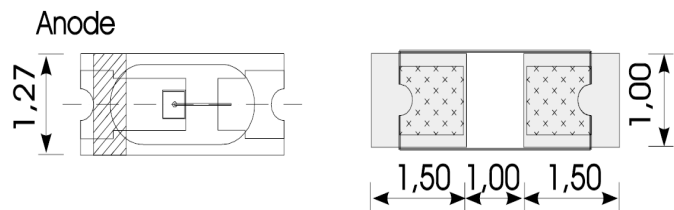

Opto-Electrical Characteristics (Ta=25°C)

Characteristic	Symbol	Test Condition	Min	Typ	Max	Unit
Forward Voltage	V _F	I _F =20mA	-	2.00	2.40	V
Reverse Current	I _R	V _R =5V	-	-	100	μA
Luminous Intensity	I _v	I _F =20mA	3.20	6.90	-	mcd
Viewing Angle	2θ ^{1/2}	-	-	180°	-	deg.
Peak Wavelength	λ _p	I _F =20mA	-	565	-	nm
Dominant Wavelength	λ _d	I _F =20mA	-	560	-	nm
Spectral Line Half Width	Δλ	I _F =20mA	-	25	-	nm

Specifications are Subject to Change Without Notice

CR 52 SG Graphs

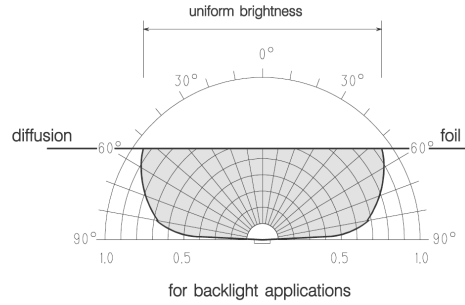
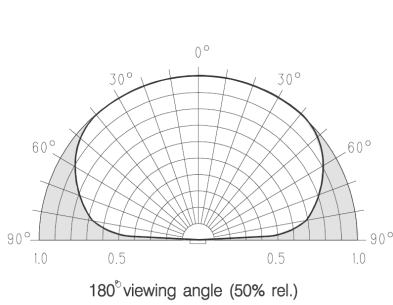

SUGGESTED MOUNTING METHOD

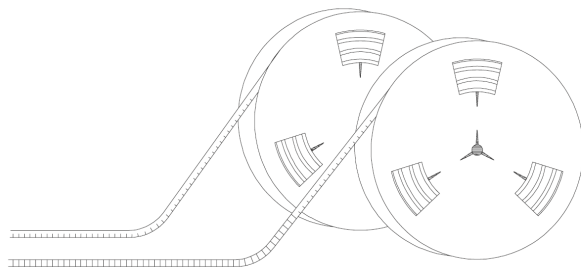
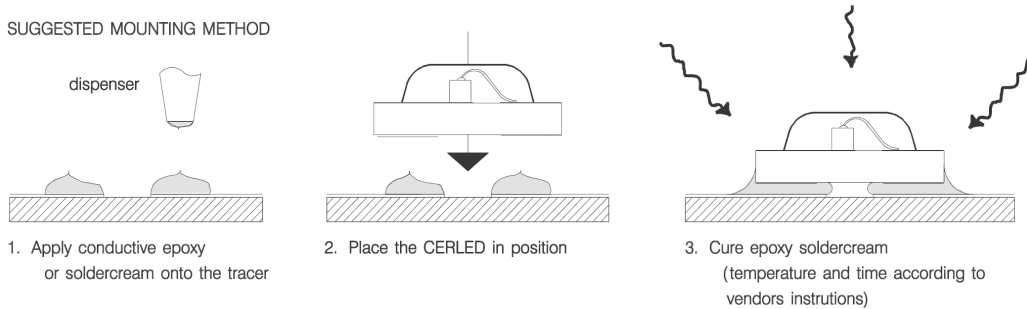

Special Packing:
standard 8mm blister tape

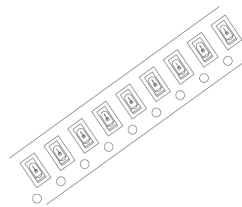

ARRAYS

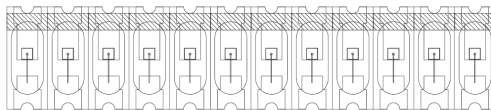

code to order strips:
CR50 XX - 10_
No of LEDs

Available in strips up to 12 CERLEDs with a max. pitch tolerance in spacing and linearity of $\pm 0,01$ mm between chip centers.